

SIDE STEPS LWB

Part Number: GRA-0A82-000590

Revised Date: 28th April 2023

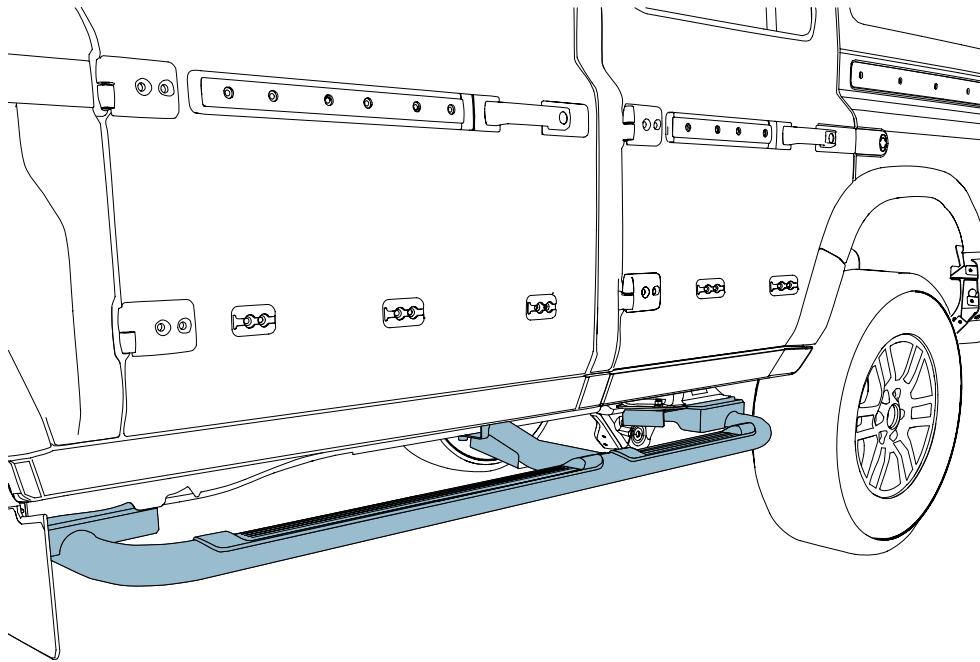

INTRODUCTION

This introduction is written for Grenadier owners and enthusiasts. It is designed to provide sufficiently detailed instructions to support those who enjoy the challenge of installing accessories to their Grenadier.

PAGE LAYOUT

Each instruction page is written in the same format:

- > The title of the fitting procedure.
- > The header table, which give technical information about the fitting procedure.
- > The parts table, which lists parts required for the task.
- > The supplies table, which lists supplies (such as oils, lubricants, adhesives) required for the task.
- > The procedure steps. Numbered and ordered, giving instructions and illustrations for each step.

WARNINGS, CAUTIONS AND NOTES

The following Warnings, Cautions and Notes are used within the repair steps:



Warning : A warning tells you that there is a risk of injury or death.



Caution : A caution tells you that there is a risk of damage to objects.



Note : A note tells you additional information that relates to the main topic.

ABBREVIATIONS

The following abbreviations are used within the Easy Repair Guide:

- > Special Service Tool (SST)
- > Manufacturer Specification Data Sheet (MSDS)

TECHNICAL QUALIFICATION

INEOS recommends that only persons who are technically competent should work on the vehicle. Work carried out by unqualified persons or using unapproved tools may result in damage to the vehicle or personal injury.

DISCLAIMER

This instruction was correct at the time of publishing. However, INEOS reserves the right to develop, improve and change any equipment, software, specifications, design, and/or information provided without notice or obligation. INEOS will not be held responsible for any inaccuracy or the consequences thereof.

©COPYRIGHT

© Copyright INEOS Automotive Limited, 2022. All Rights Reserved. These technical publications are provided for use by authorised users only. Under no circumstances should the content of any of the technical publications be reproduced, stored in a retrieval system or transmitted, in any form, electronic, mechanical, photocopying, recording or other means without prior written permission from INEOS Automotive Limited.

TABLE OF CONTENTS

Side Steps (Station Wagon And Utility Wagon) (Accessory Install)	4
Parts	4
Tools	5
Procedure	7

SIDE STEPS (STATION WAGON AND UTILITY WAGON) (INSTALL)

SIDE STEPS (STATION WAGON AND UTILITY WAGON) (ACCESSORY INSTALL)

Part Number	GRA-0A82-000590
Operation	Install
Model Year	Common
Body	LWB / SW & UV
Repair Time	0.5 hour

PARTS

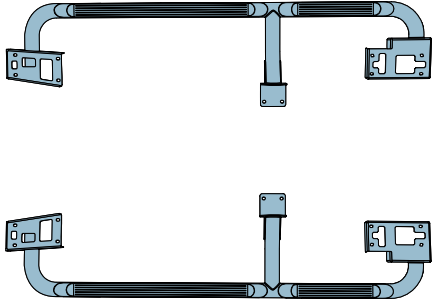
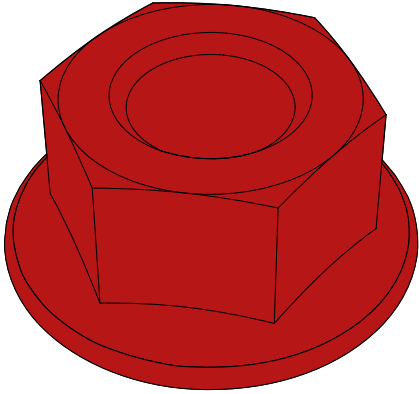
Part Number	Description	Image	Qty
GRA-0A82-000590	Side Step Kit		1
Part of Kit	Nut Flanged 10x1.5		8

SIDE STEPS (STATION WAGON AND UTILITY WAGON) (INSTALL)

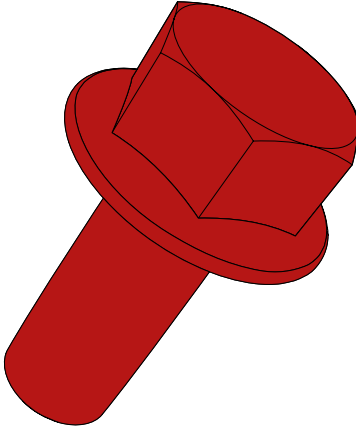
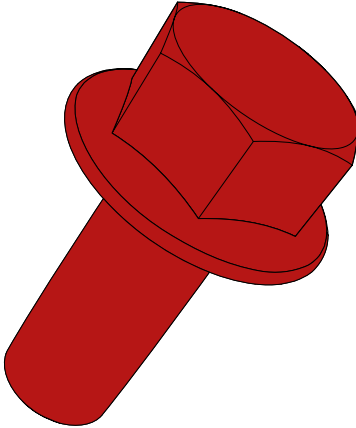
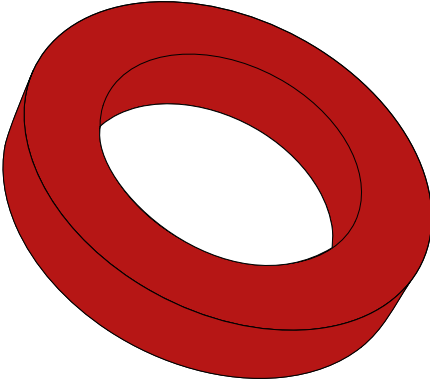
Part Number	Description	Image	Qty
Part of Kit	Bolt M12x30x1.5 Flanged Hex head		8
Part of Kit	Bolt M10x30x1.5 Flanged Hex Head		6
Part of Kit	Washer		20

TOOLS

Part Number	Description	Image	Qty
Local Supply	Jack	1	

SIDE STEPS (STATION WAGON AND UTILITY WAGON) (INSTALL)

Part Number	Description	Image	Qty
Local Supply	Torque Wrench		1
Local Supply	1/2" Ratchet		1
Local Supply	1/2" Extension		1

SIDE STEPS (STATION WAGON AND UTILITY WAGON) (INSTALL)

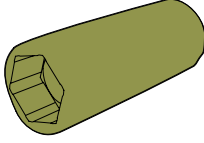
Part Number	Description	Image	Qty
Local Supply	1/2" Socket		1

PROCEDURE

Install

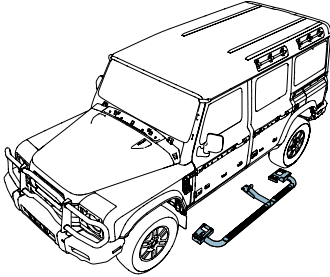
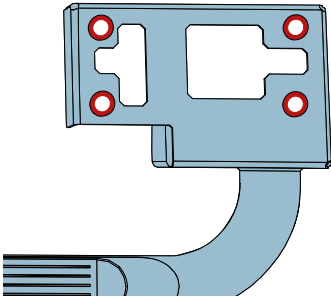
1	Put the Side Step onto an applicable Jack.	
2	Put the 4 washers into position rear Side Step Bracket.	

SIDE STEPS (STATION WAGON AND UTILITY WAGON) (INSTALL)

3

Put the 2 washers into position middle Side Step Bracket.

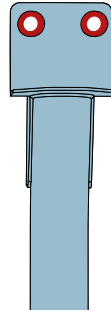

4

Put the 4 washers into position front Side Step Bracket.

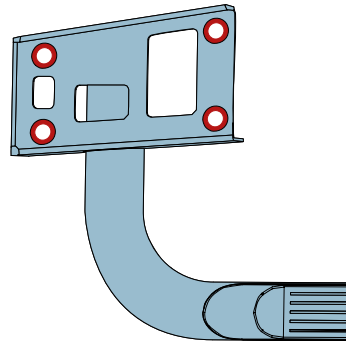

5

Carefully use the Jack to lift the Side Step into position.

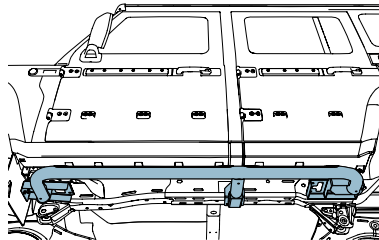

6



Note: Make sure that the two Washers are correctly aligned.

Loosely install the three bolts that attach the Side Step to the Chassis ensuring bottom two bolts are installed first.

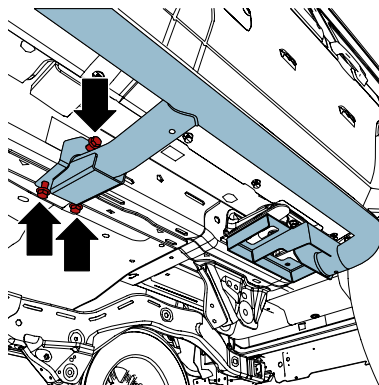

SIDE STEPS (STATION WAGON AND UTILITY WAGON) (INSTALL)

7

 *Note: Make sure that the four Washers are correctly aligned.*

Loosely install the four bolts that attach the Side Step to the front Body Mount Bracket.

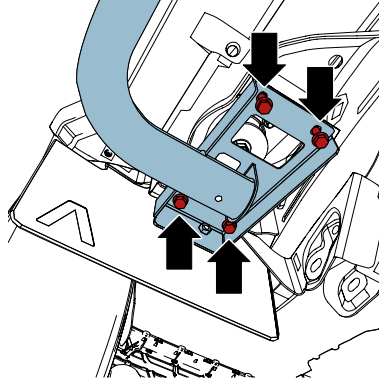

8

Put the four nuts into position.

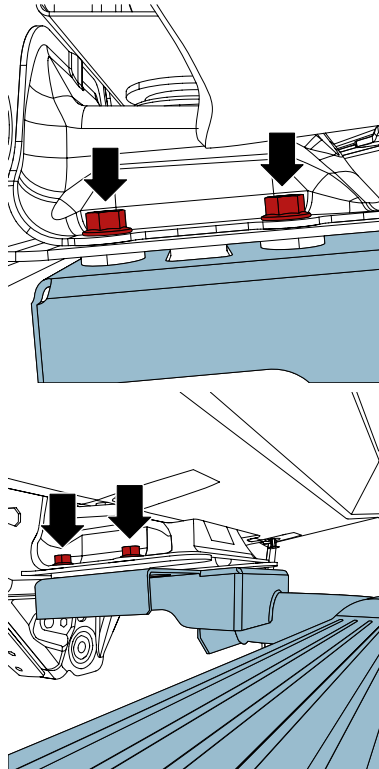

9

 *Note: Make sure that the four Washers are correctly aligned.*

Install and torque the three bolts that attach the Side Step to the Chassis to **110 Nm**

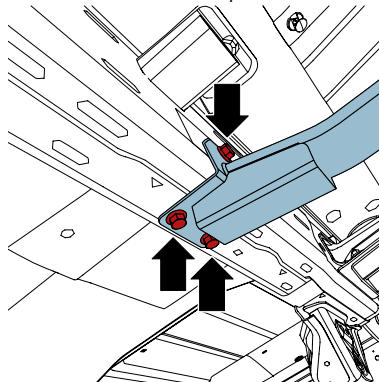

SIDE STEPS (STATION WAGON AND UTILITY WAGON) (INSTALL)

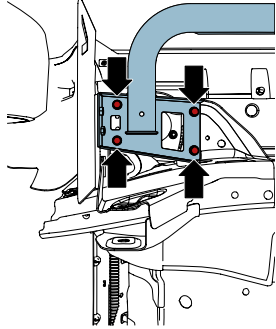
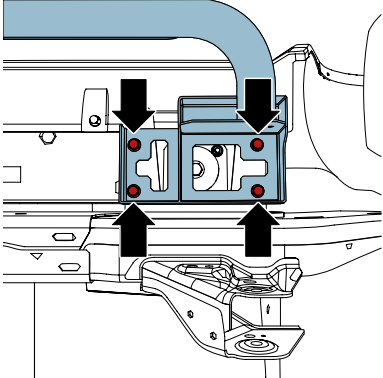
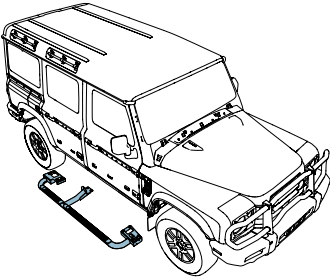
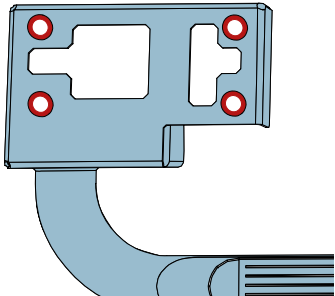
10	<p>Torque the four bolts that attach the Side Step to the front Body Mount Bracket to 64 Nm</p> 
11	<p>Torque the four bolts that attach the Side Step to the rear Body Mount Bracket to 64 Nm</p> 
12	<p>Move the Jack to the right side of the Vehicle.</p>
13	<p>Put the Side Step onto an applicable Jack.</p> 
14	<p>Put the 4 washers into position on the rear Side Step Bracket.</p> 

SIDE STEPS (STATION WAGON AND UTILITY WAGON) (INSTALL)

15

Put the 2 washers into position on the middle Side Step Bracket.

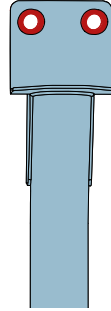

16

Put the 4 washers into position on the front Side Step Bracket.

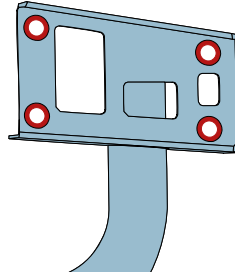

17

Carefully use the Jack to lift the Side Step into position.

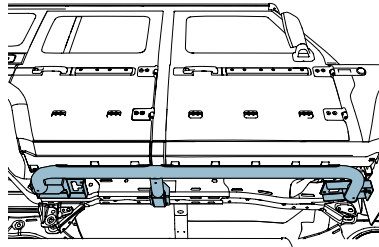

18



Note: Make sure that the two Washers are correctly aligned.

Loosely install the three bolts that attach the Side Step to the Chassis ensuring bottom two bolts are installed first.

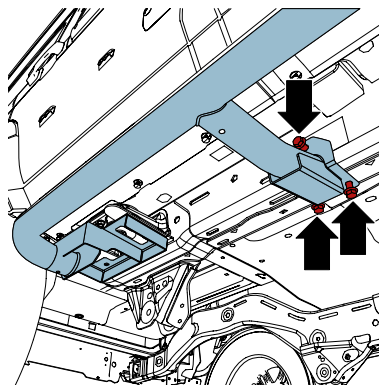

SIDE STEPS (STATION WAGON AND UTILITY WAGON) (INSTALL)

19

 *Note:*

Loosely install the four bolts that attach the Side Step to the front Body Mount Bracket.

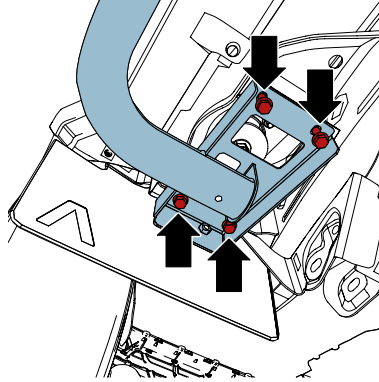

20

Put the four nuts into position.

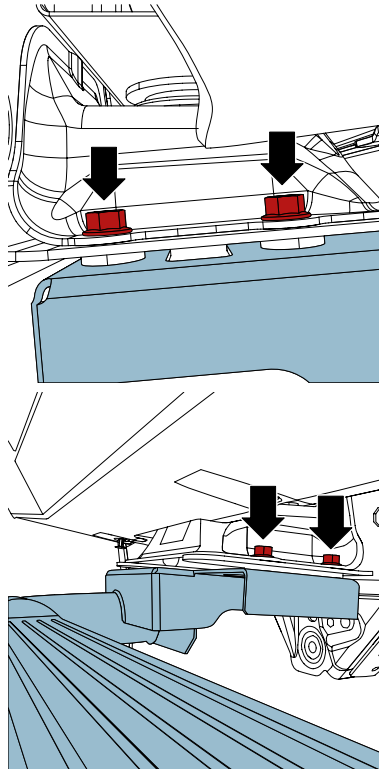

21

 *Note: Make sure that the four Washers are correctly aligned.*

Install and torque the three bolts that attach the Side Step to the Chassis to **110 Nm**

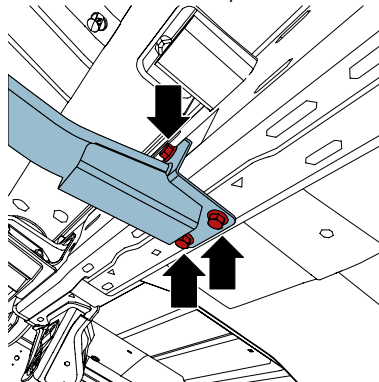

SIDE STEPS (STATION WAGON AND UTILITY WAGON) (INSTALL)

22

Torque the four bolts that attach the Side Step to the front Body Mount Bracket to **64 Nm**

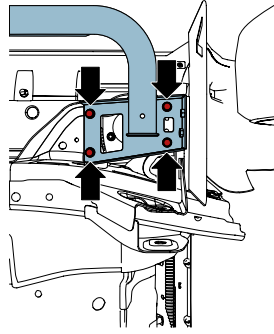

23

Install and torque the four bolts that attach the Side Step to the rear Body Mount Bracket to **64 Nm**

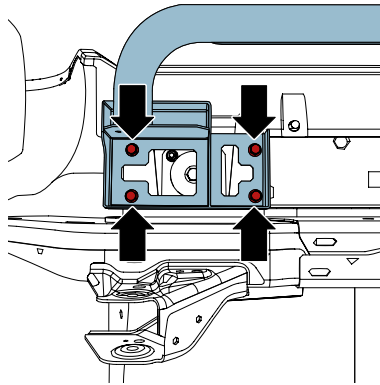

24

Move the Jack away from the Vehicle.

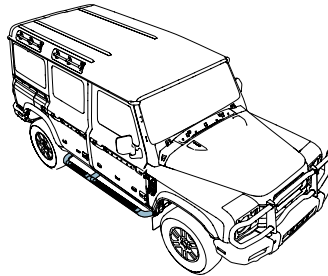

INEOS

GRENA^ADIER