

INEOS | GRENADIER

INEOS GRENADIER 8FT ROOF RACK

GRA-0A01-032490

Important:

1. Check the INEOS website to ensure you have the latest issue of these instructions.
2. Please refer to your fitting instruction to ensure that the roof racks are installed in the correct locations.
3. Check the contents of kit before commencing fitment and report any discrepancies.
4. Place these instructions in the vehicle's glove box after installation is complete.
5. These instructions must be followed for warranty to be upheld.

Fit Time: 3 hours

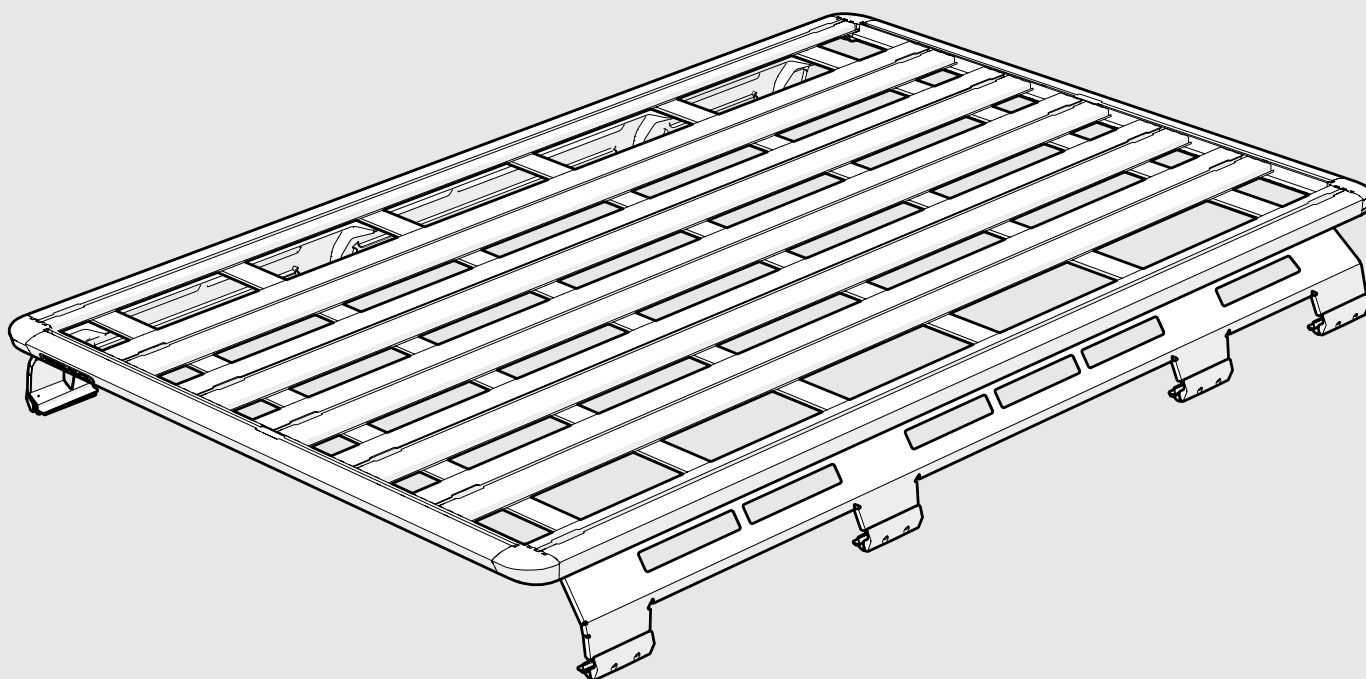

REQUIRED:



Document No: 520-RFI-00121

Issue No: 05

Issue Date: 04/03/2024

Carrying Capacity

Check your vehicle owners hand book for vehicle maximum carrying capacity. Please ensure roof system weight does not surpass your vehicle manufacturers maximum roof allowance. Load must be evenly distributed over the system.

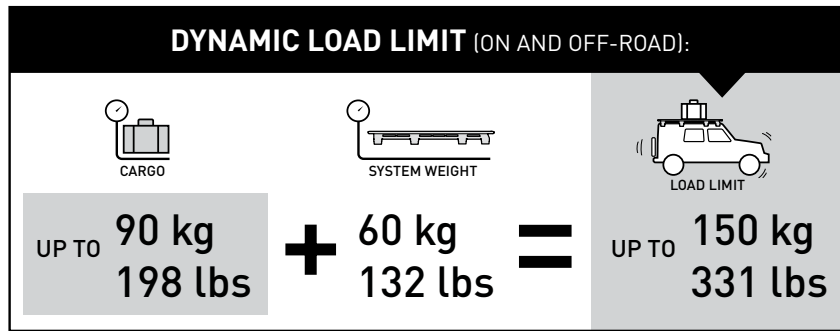

Platform dimensions

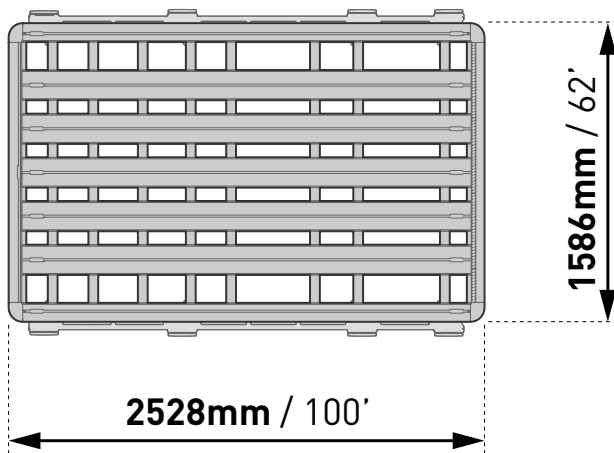

Warning

- Check part number or kit is correct for use with your vehicle.
- Do not attempt to fit the rack system to your vehicle unless you fully understand these fitting instructions. Please direct any questions regarding fitting to the dealer from where the roof racks were purchased.
- Off-road conditions can be much more rigorous. Extreme care must be taken in off road conditions.
- Roof racks must be removed when vehicle is put through an automatic car wash.
- With utility vehicles, the cabin and the canopy move independently. Roof racks and vehicle can be damaged if the item transported is rigidly fixed at points on both the cabin and canopy. Instead, rigidly fix to either the cabin roof racks or the canopy roof racks.
- Always ensure you fasten your load securely.
- Use only non-stretch fastening ropes or straps to attach cargo to your load.

In service maintenance checks

- All bolt connections should be checked after driving a short distance when you first install your roof racks.
- All bolted connections should be checked again at regular intervals (weekly is recommended, depending on road conditions, usage, loads and distances travelled).
- All bolted connections should be checked each time they are re-fitted.
- Off-road conditions are more rigorous. Check all bolted connections and your load more regularly.
- Ensure that your vehicle manufacturer's Gross Vehicle Mass (GVM), and gross axle weights are not exceeded (refer to vehicle owner's manual).

Note for Dealers and Fitters

It is your responsibility to ensure these fitting instructions are given to the end user or client. These instructions may not be used or changed for any other purpose than intended.

Platform Parts

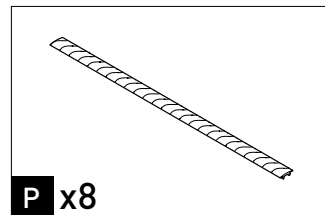
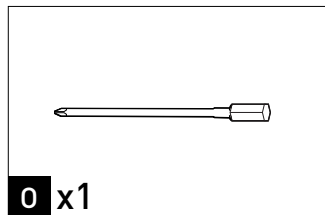
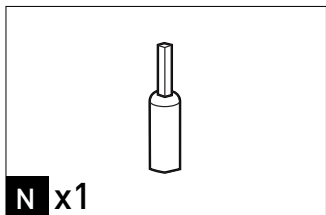
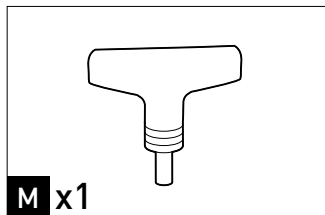
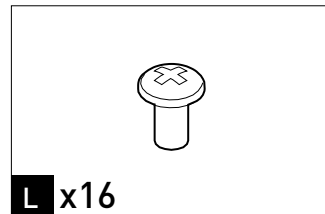
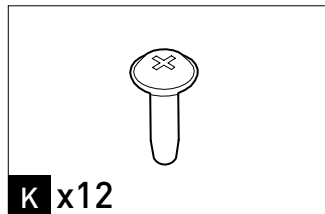
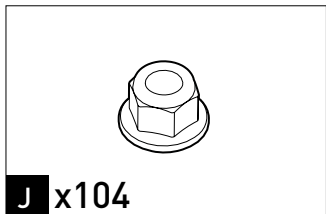
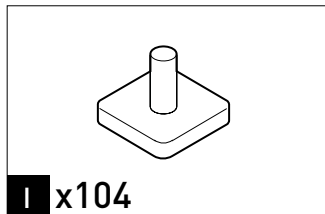
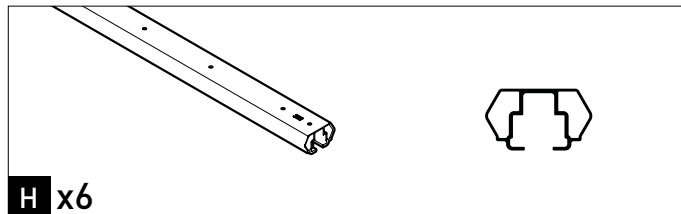
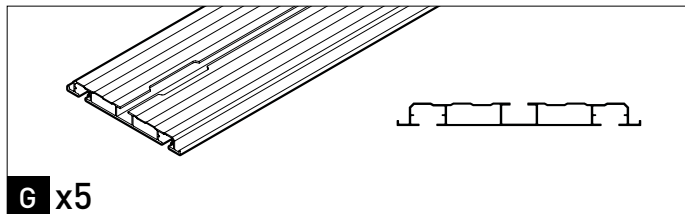
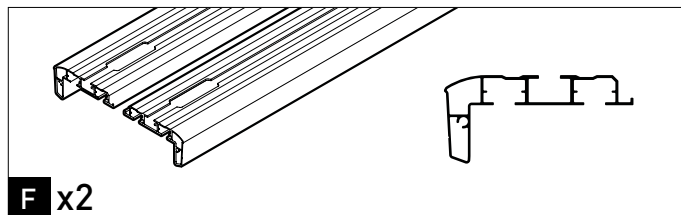
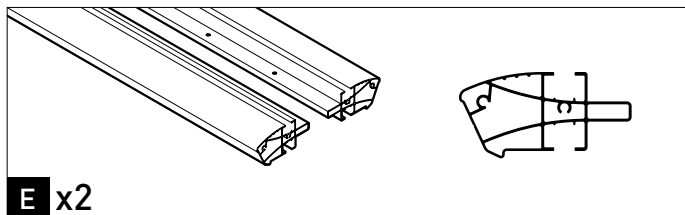
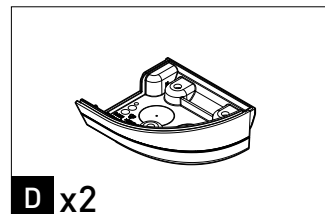
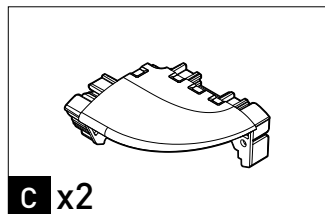
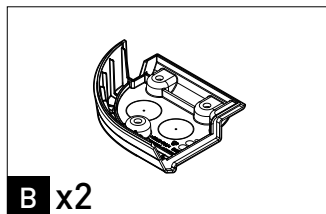
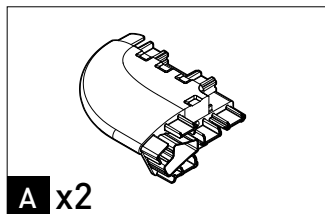

Backbone Parts

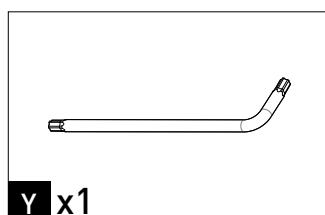
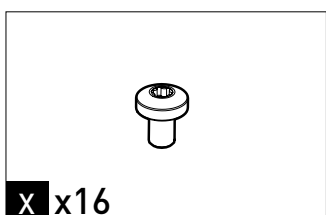
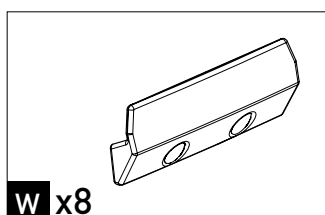
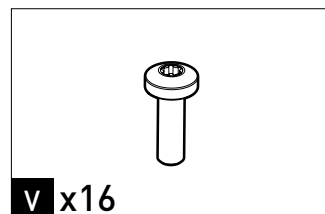
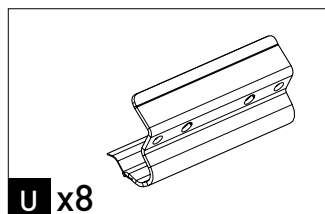
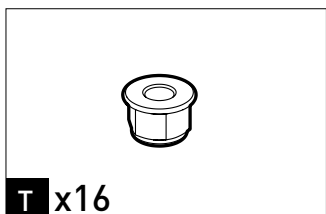
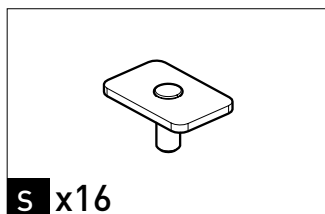
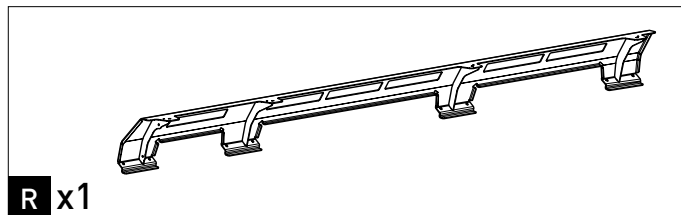
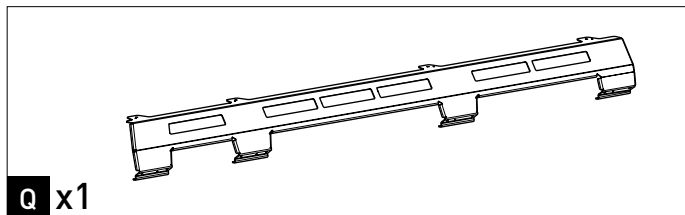

- TOOLS REQUIRED:**
- T1 - Phillips Head Screwdriver
 - T2 - Power Drill
 - T3 - Scissors
 - T4 - Torque Wrench with 13mm Socket (1/2")
 - T5 - Torque Wrench with T40 Drive
 - T6 - Step Ladder
 - T7 - Measuring Tape

1

I x6
per channel

F

F

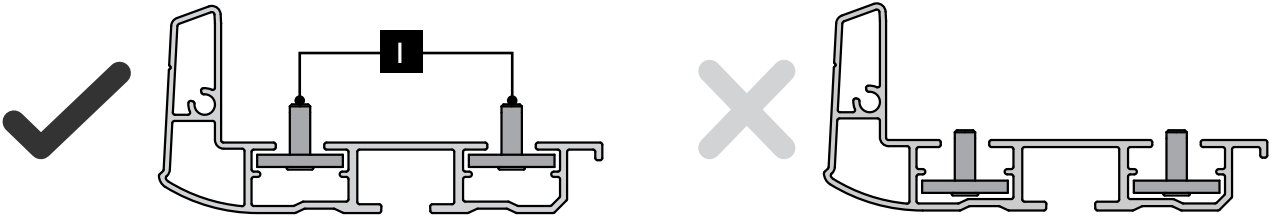

2

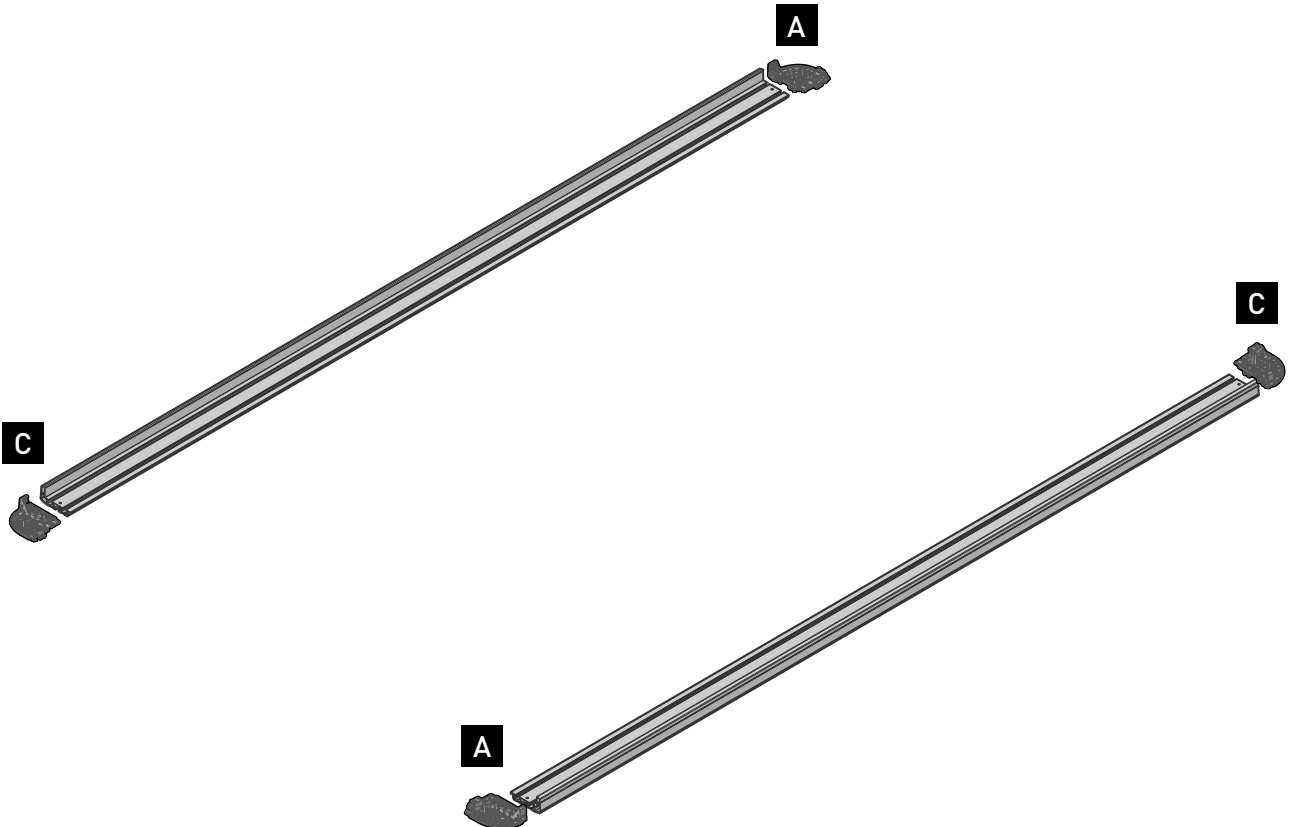

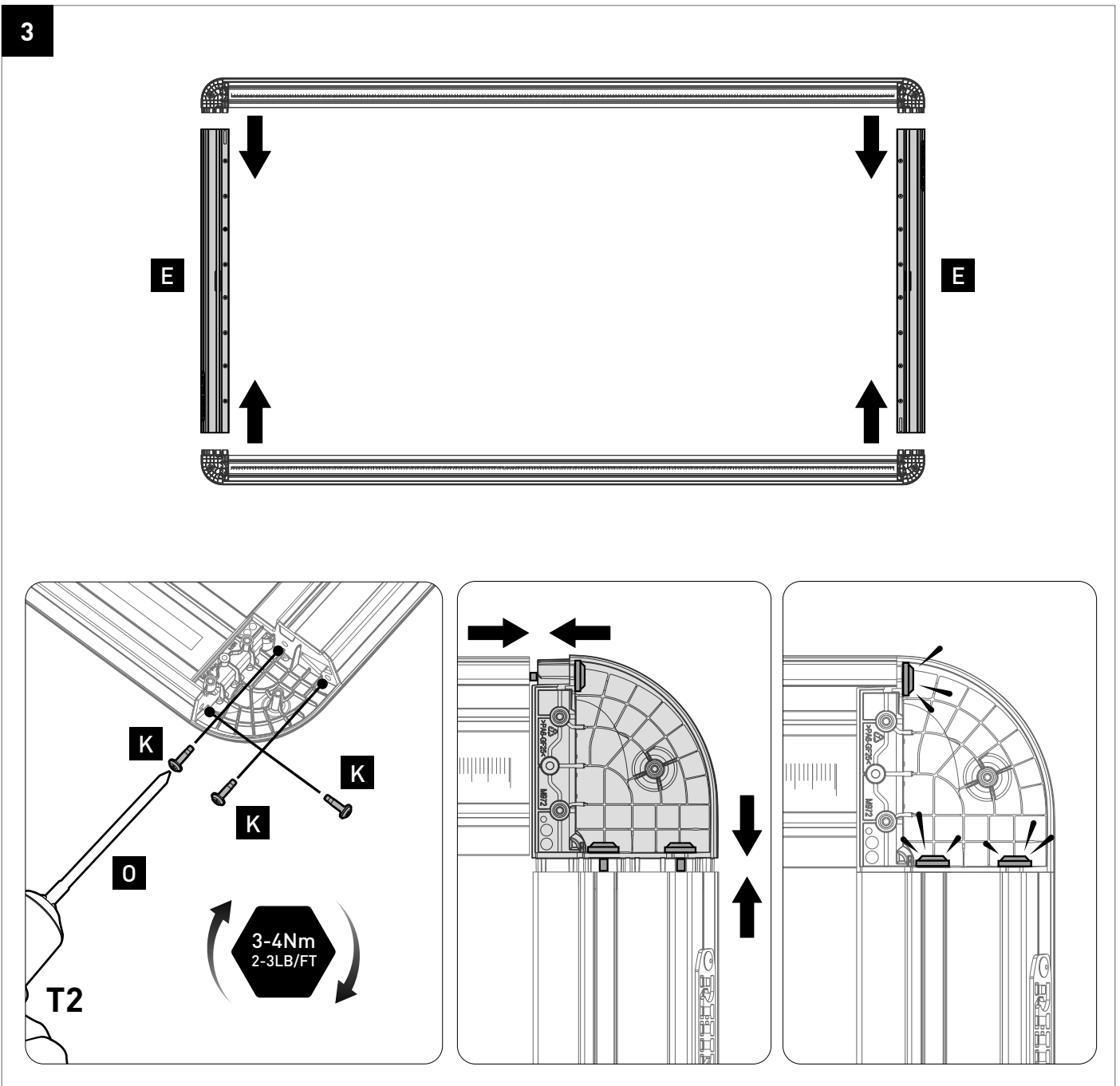
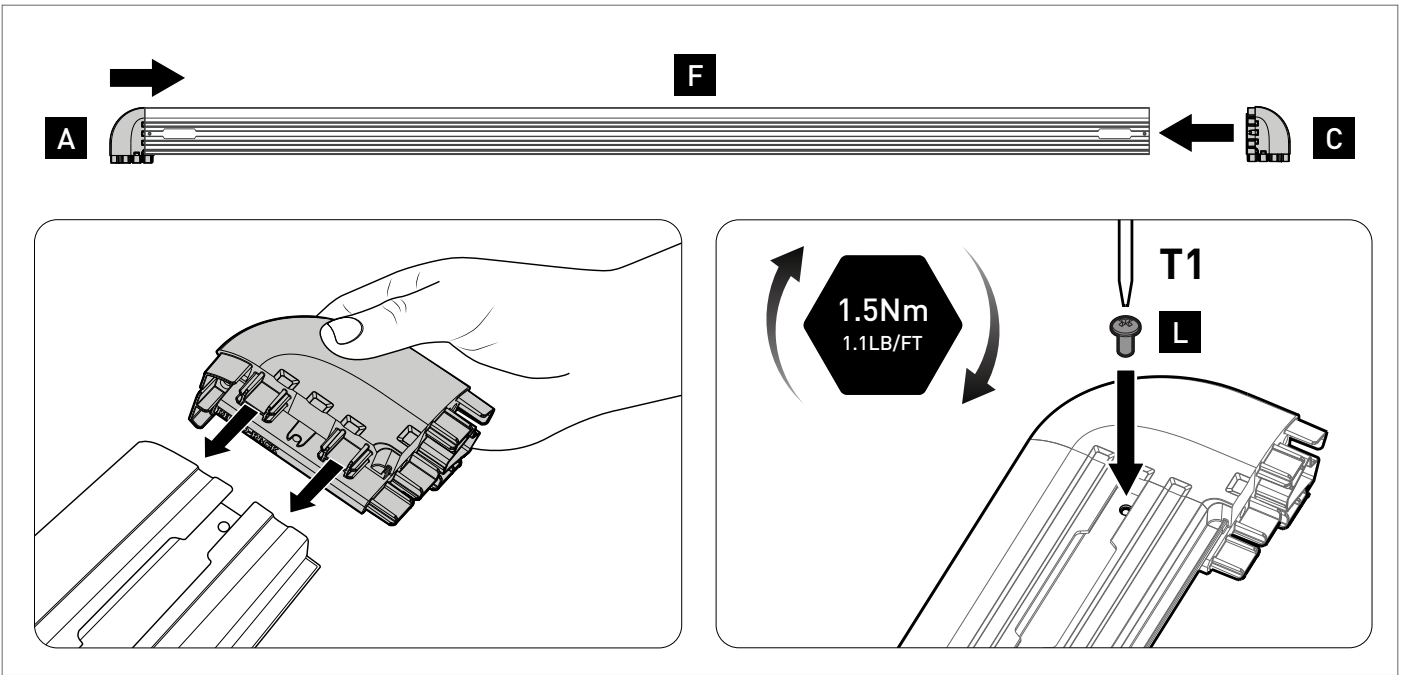

4

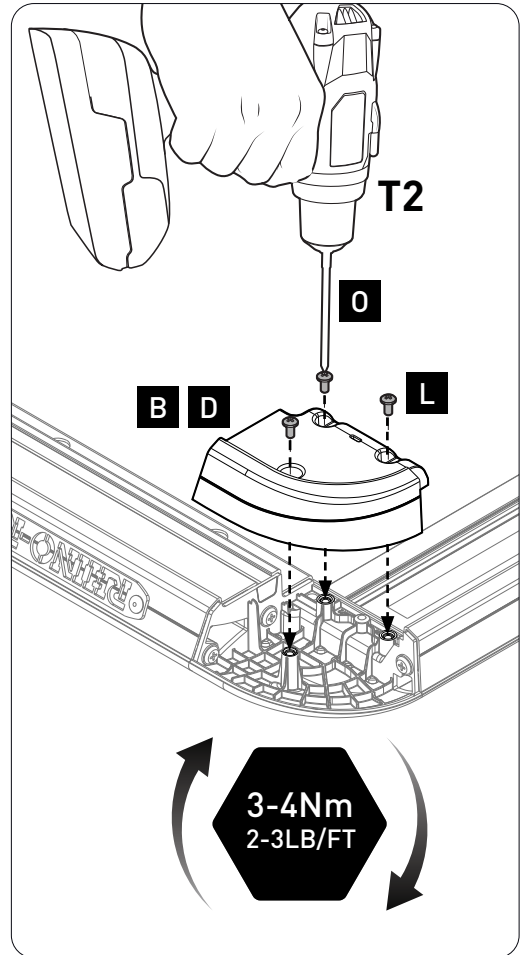
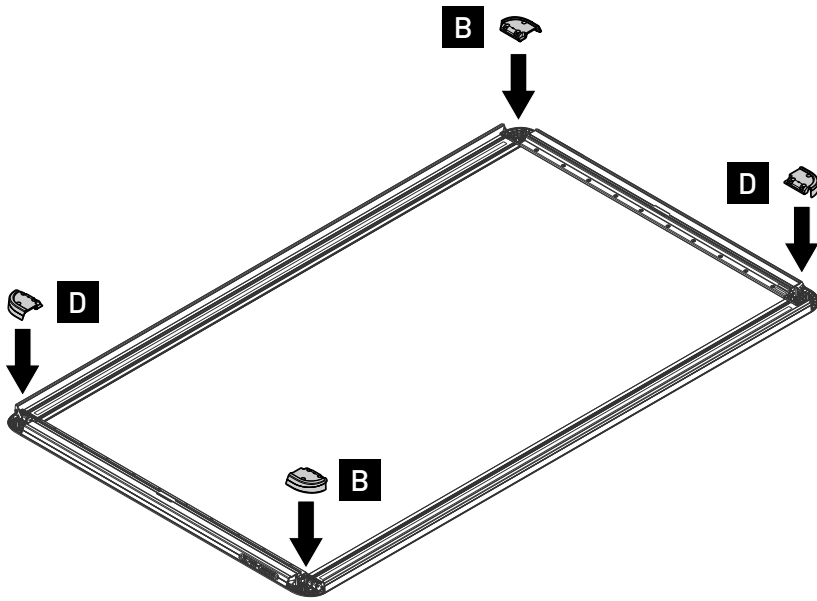

5

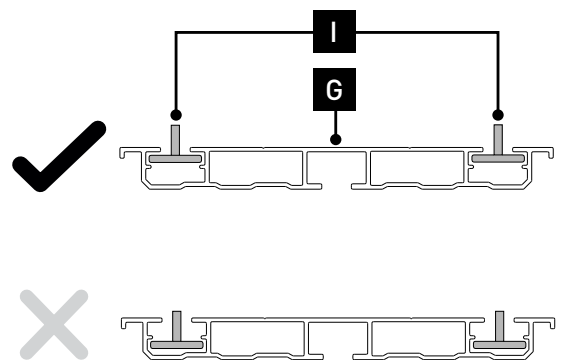
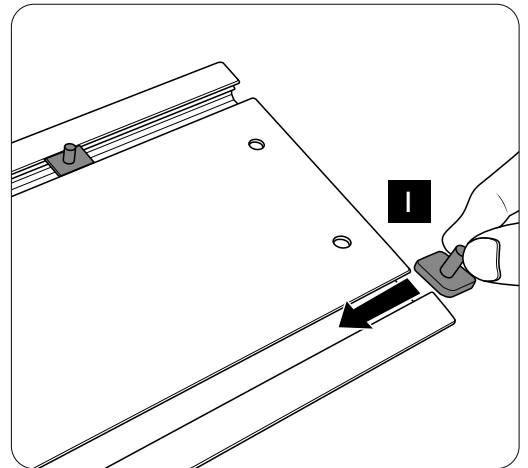
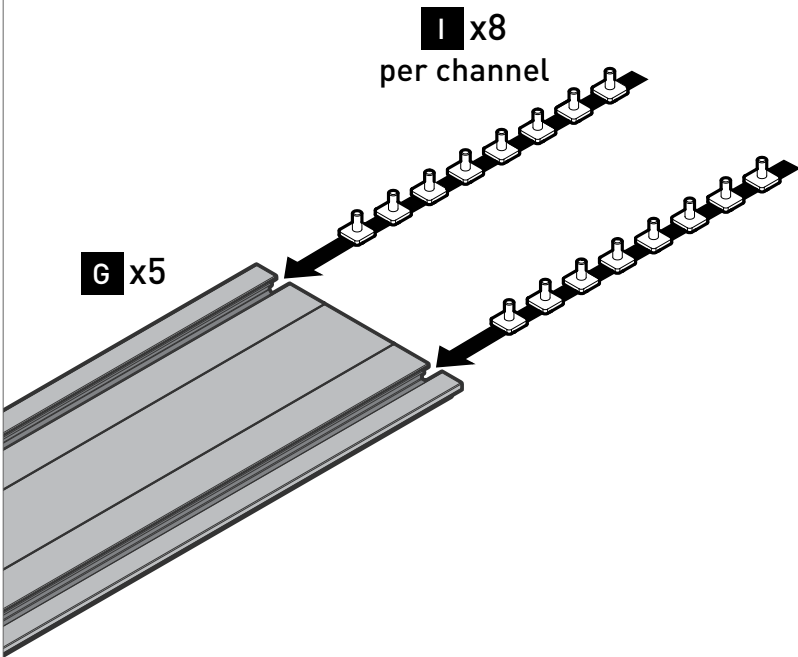

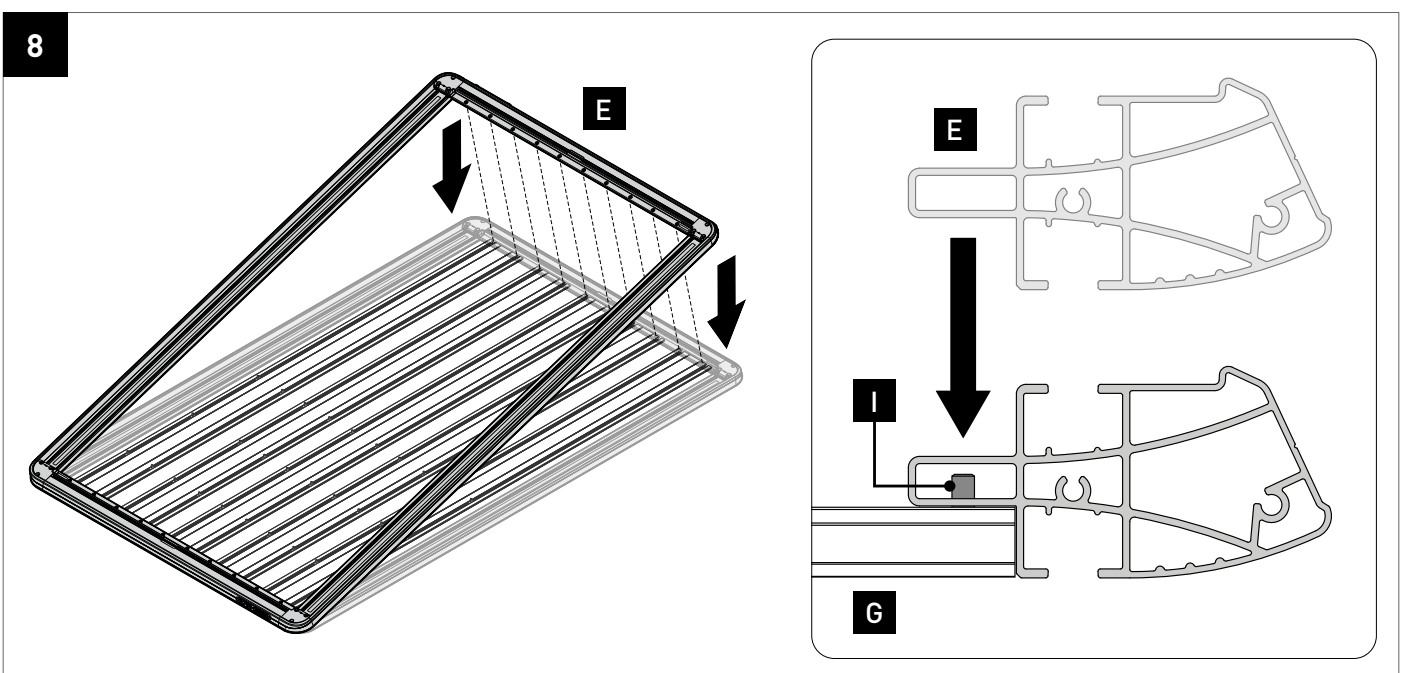
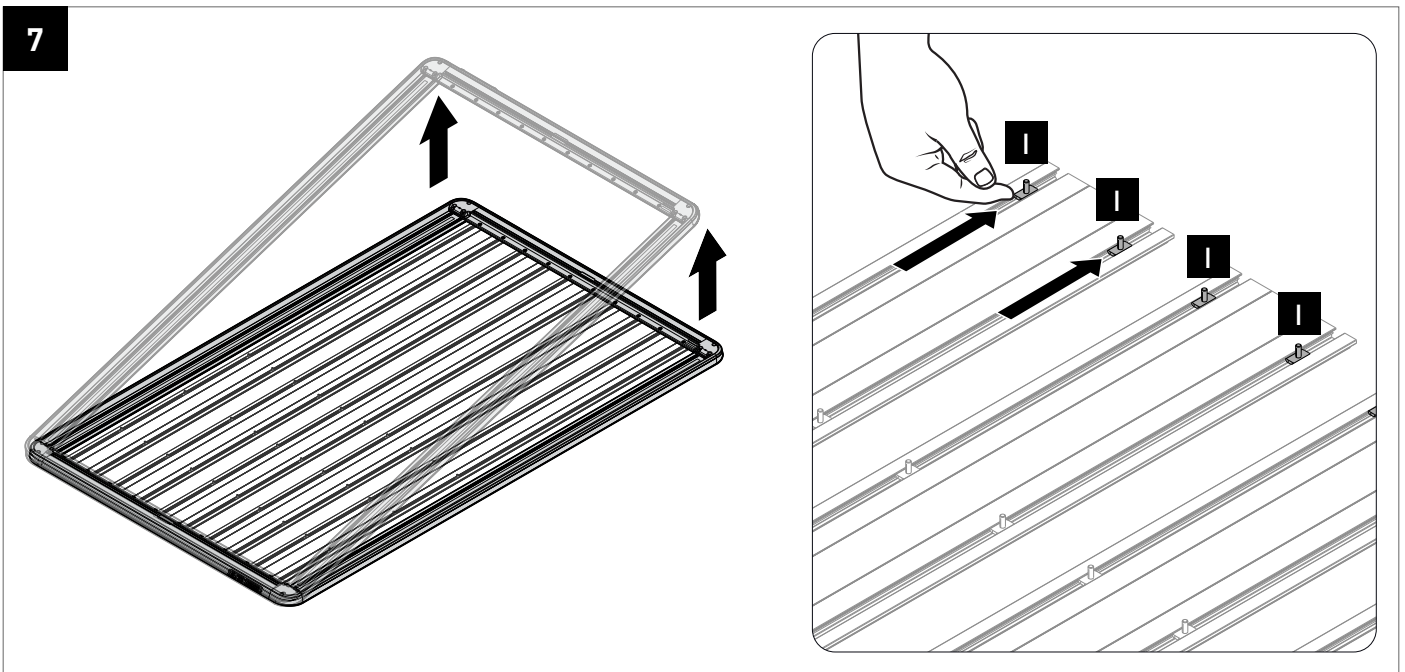
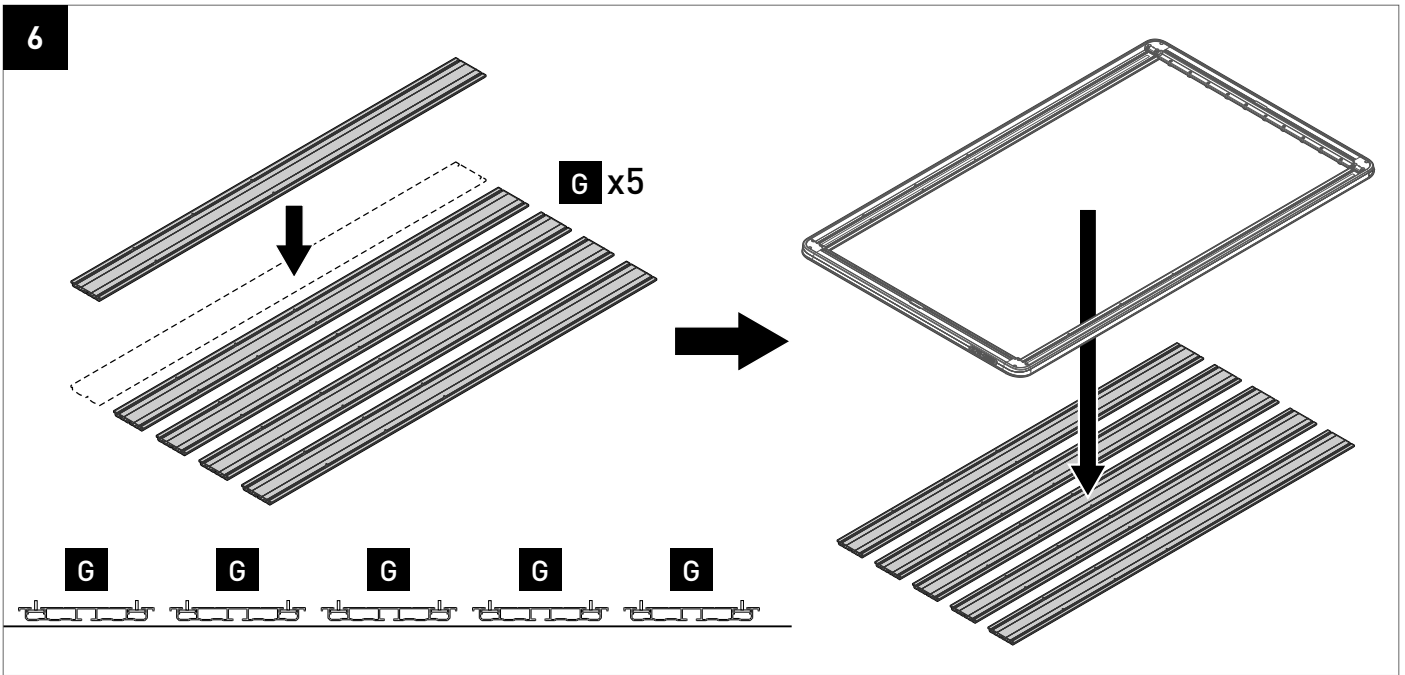

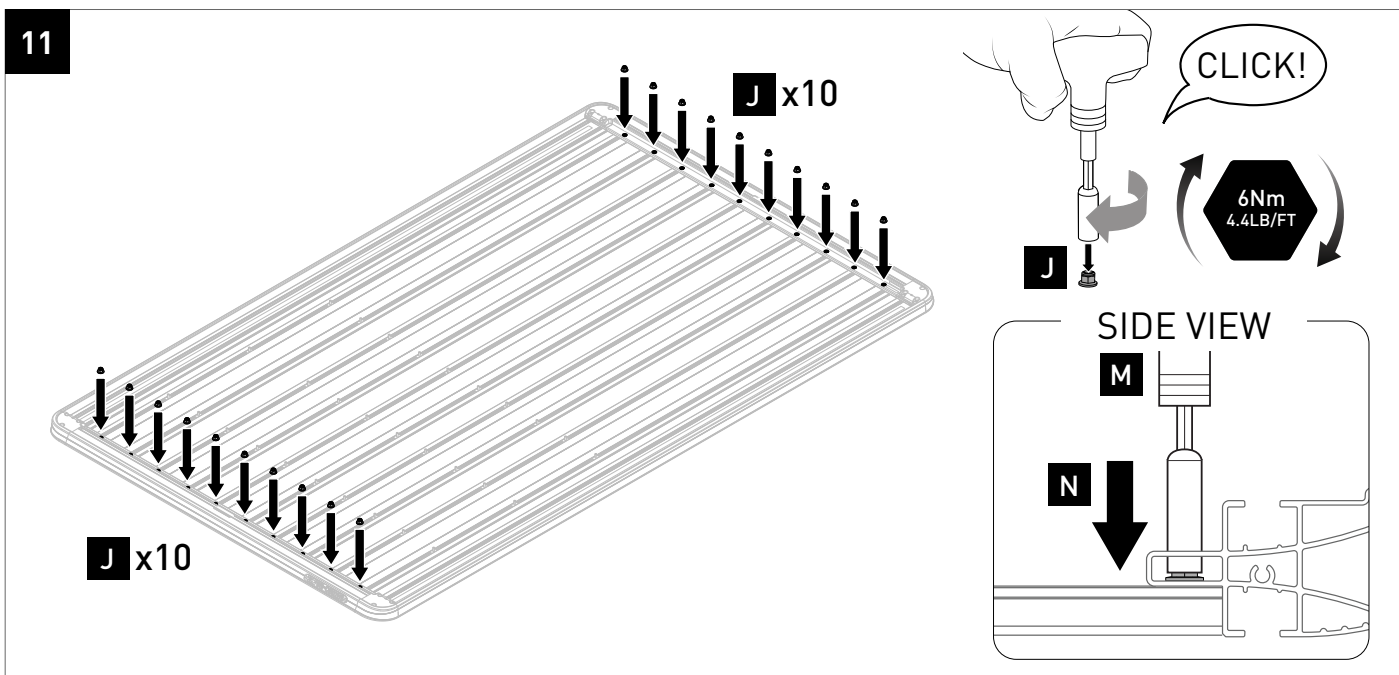
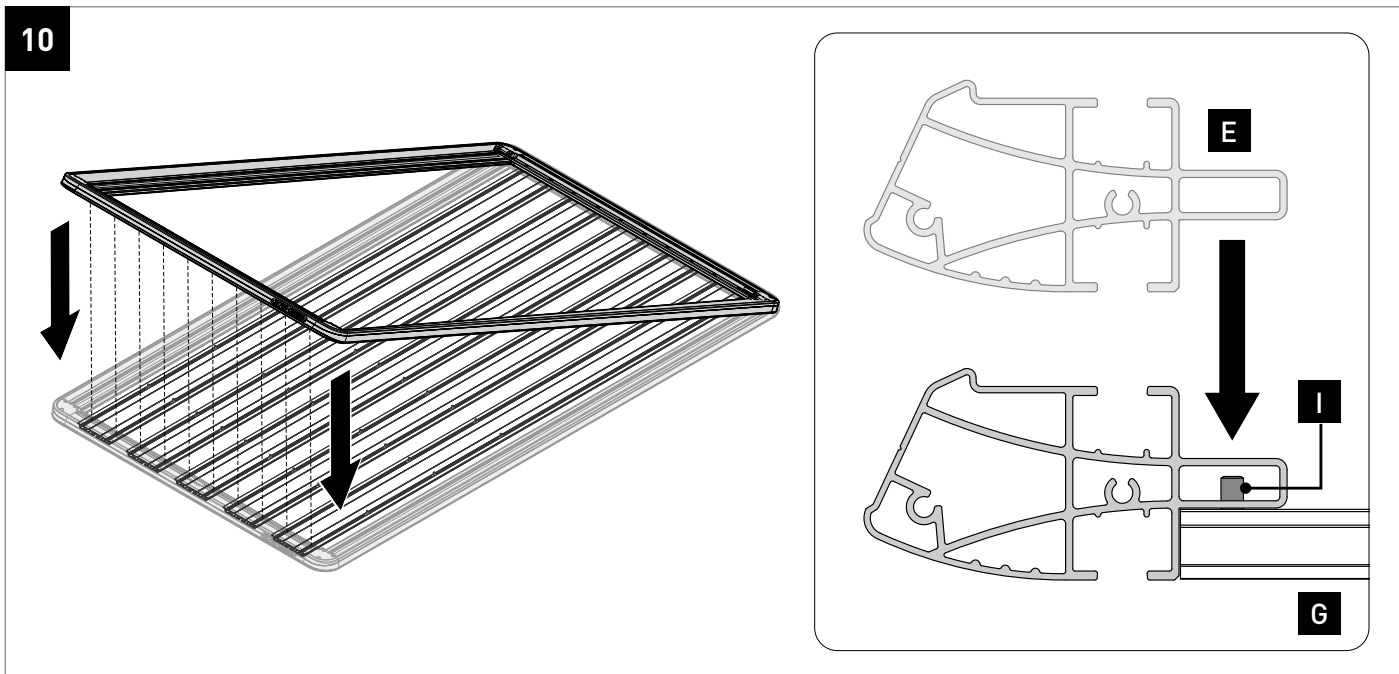
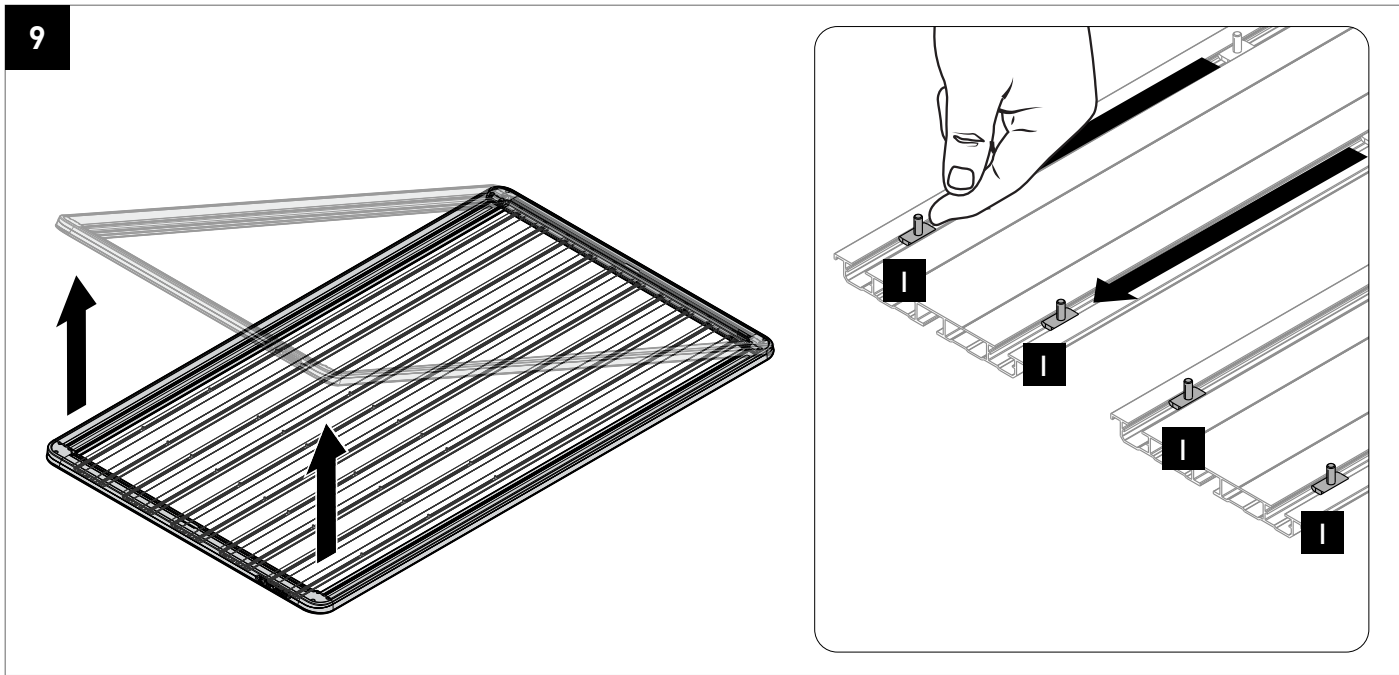

12

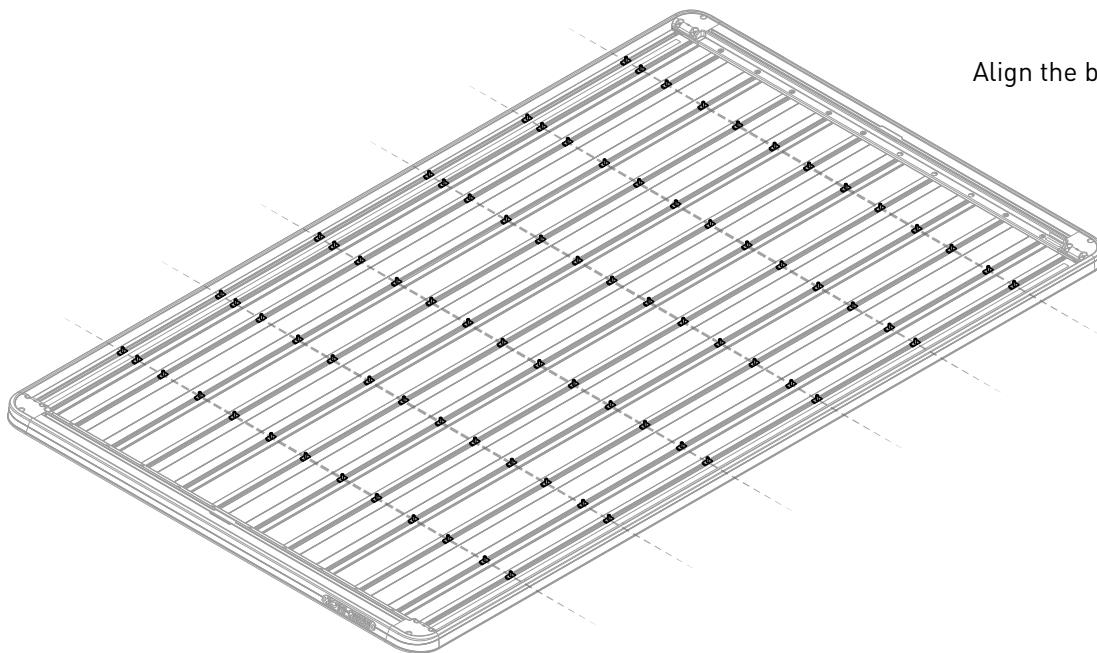

Align the bolts **I**

13

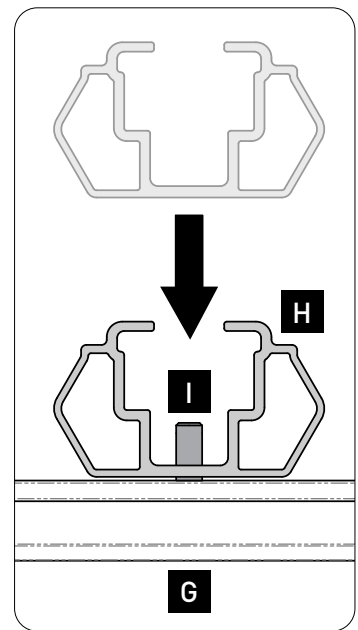
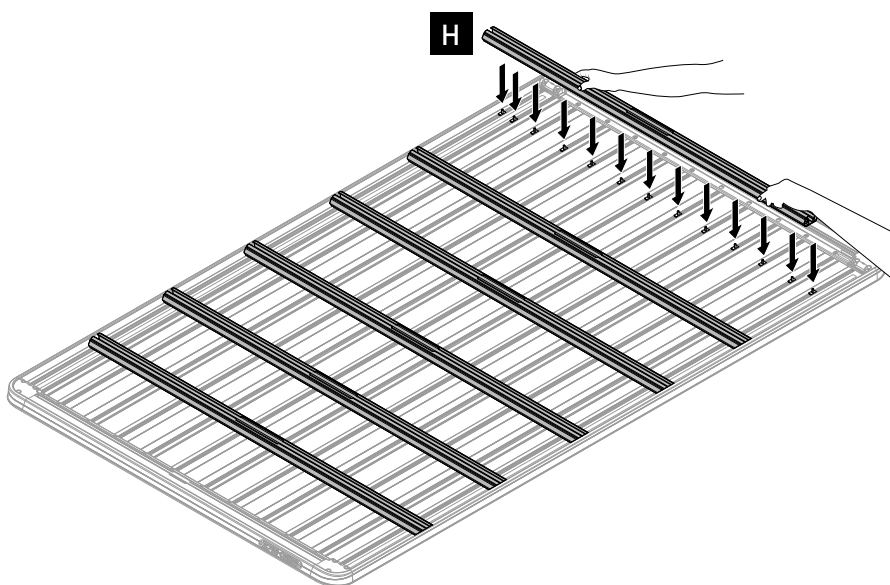

14

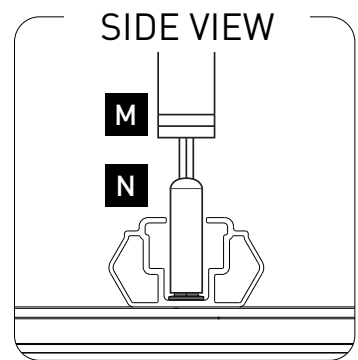
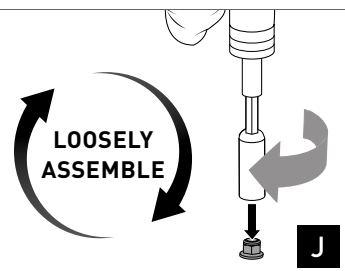
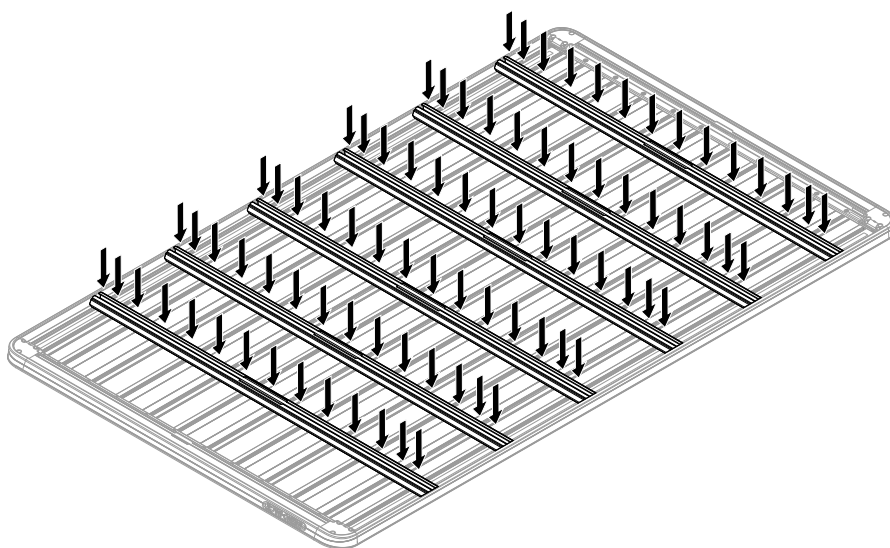

15

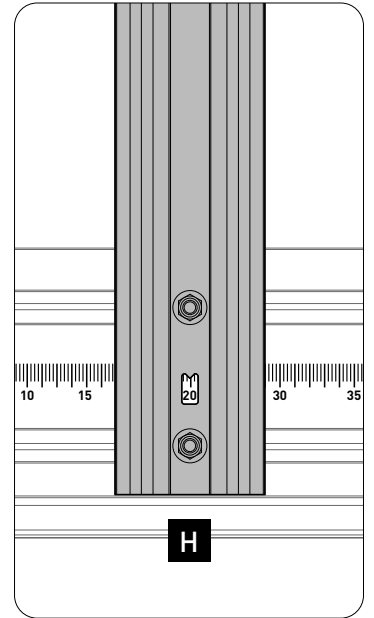
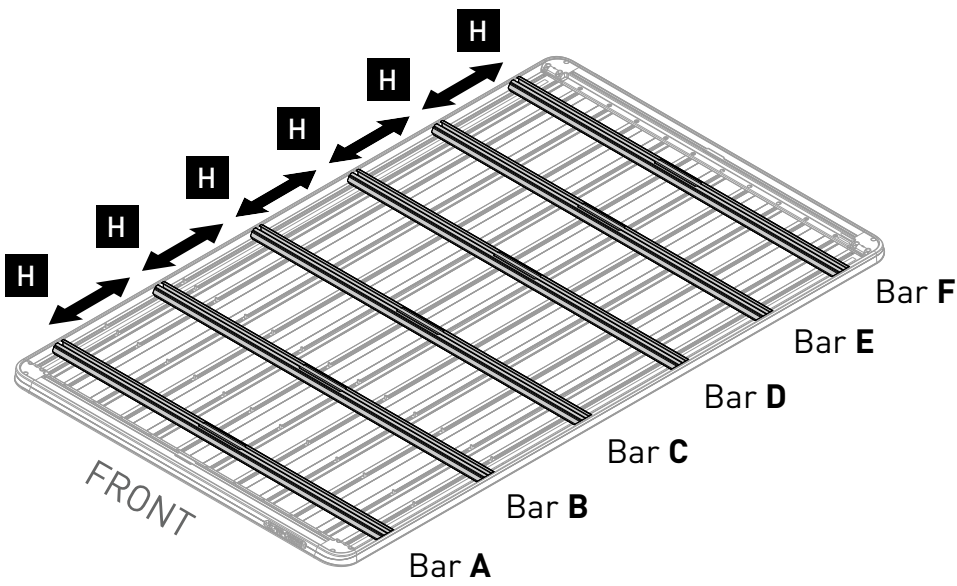

FRONT

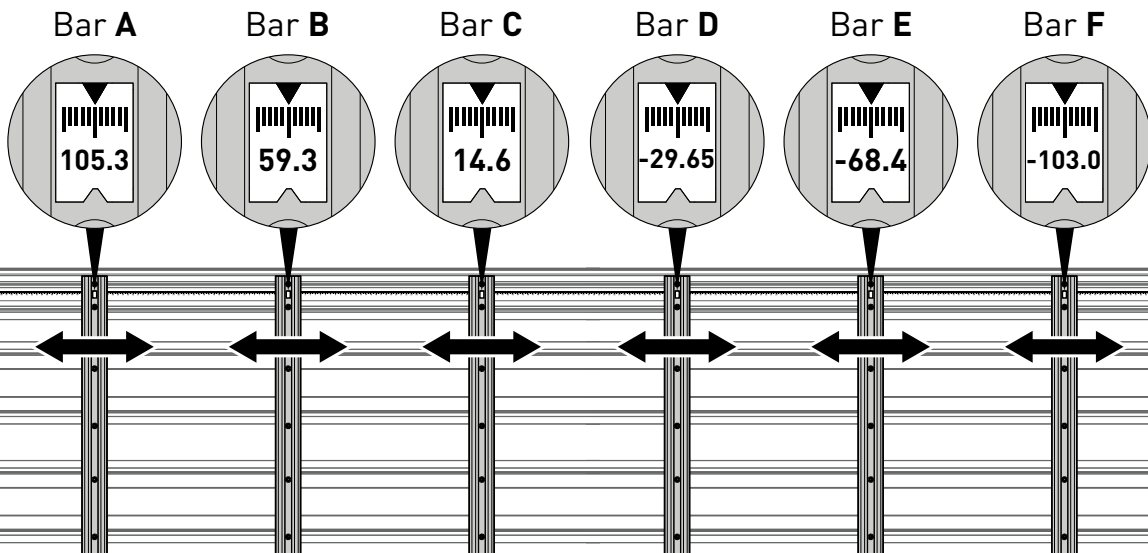

REAR

16

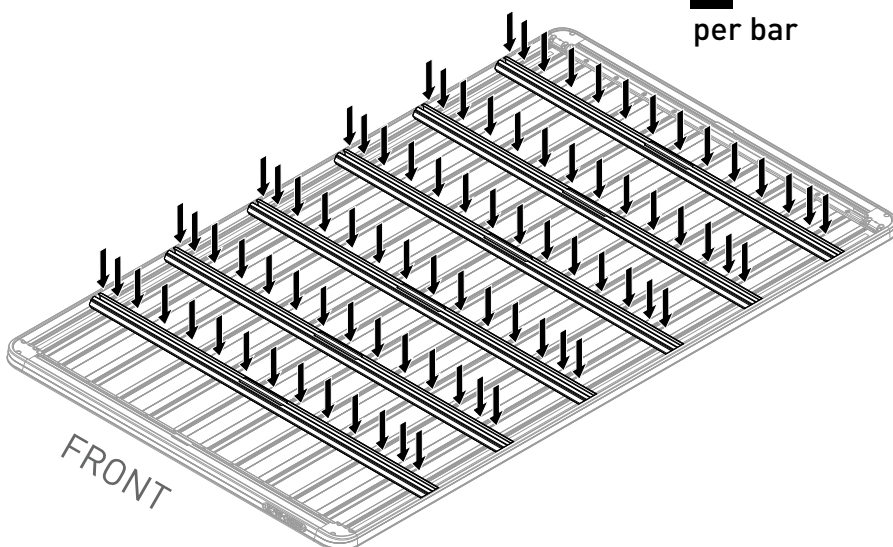

J x14
per bar

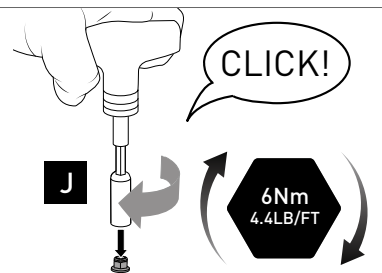

SIDE VIEW

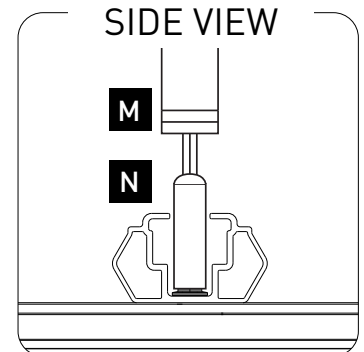

NOTE

ONLY REQUIRED WHEN INSTALLING ACCESSORIES AND HIDING ACCESSORY WIRES

- Proceed to Step 17 if not wiring accessories and refer to this note when hiding accessory wiring.

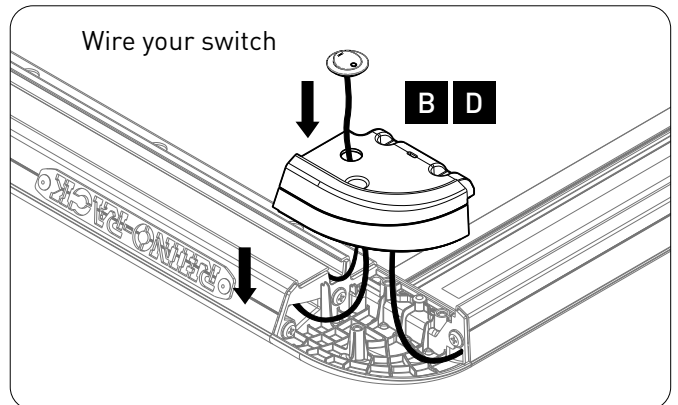
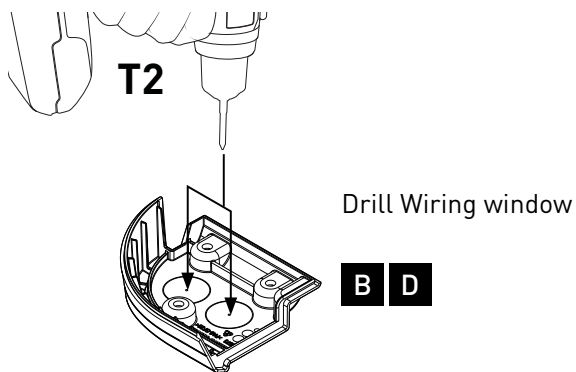
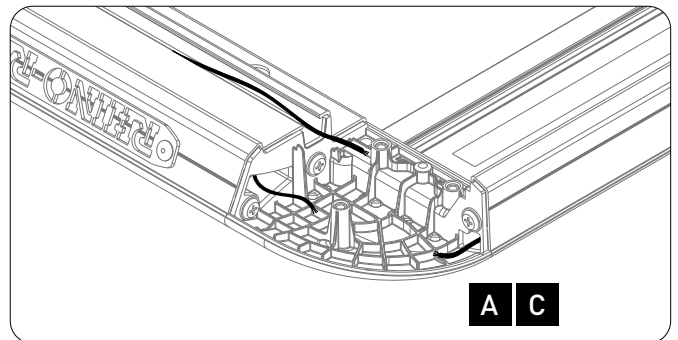
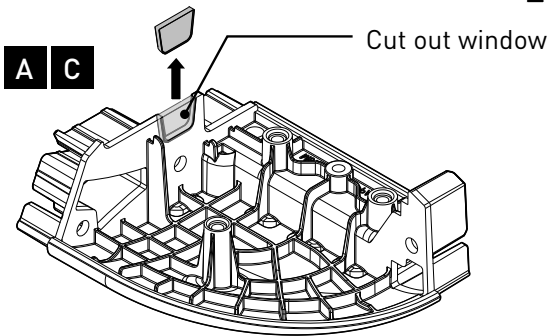
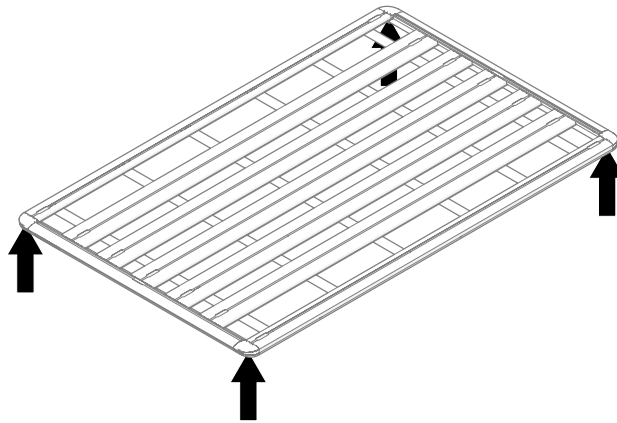

17

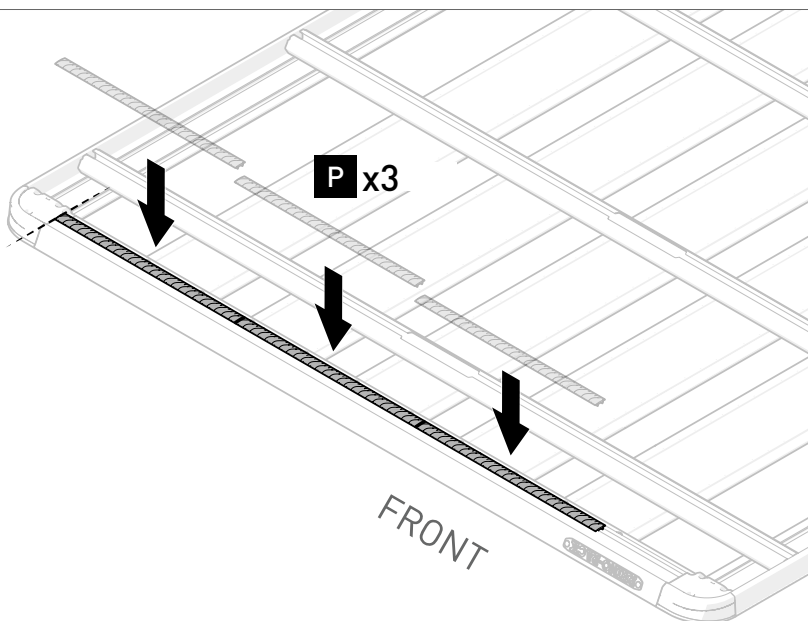

SIDE VIEW

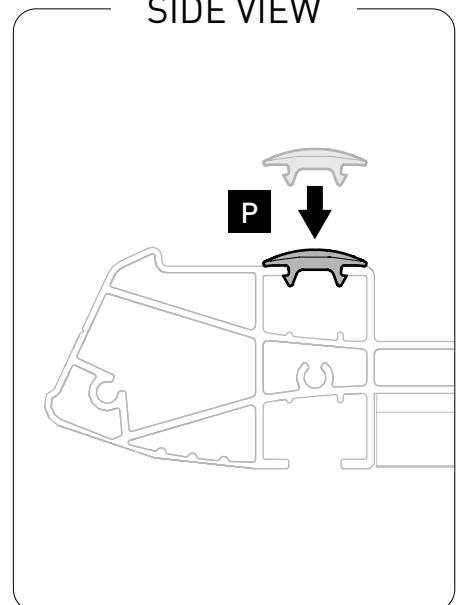

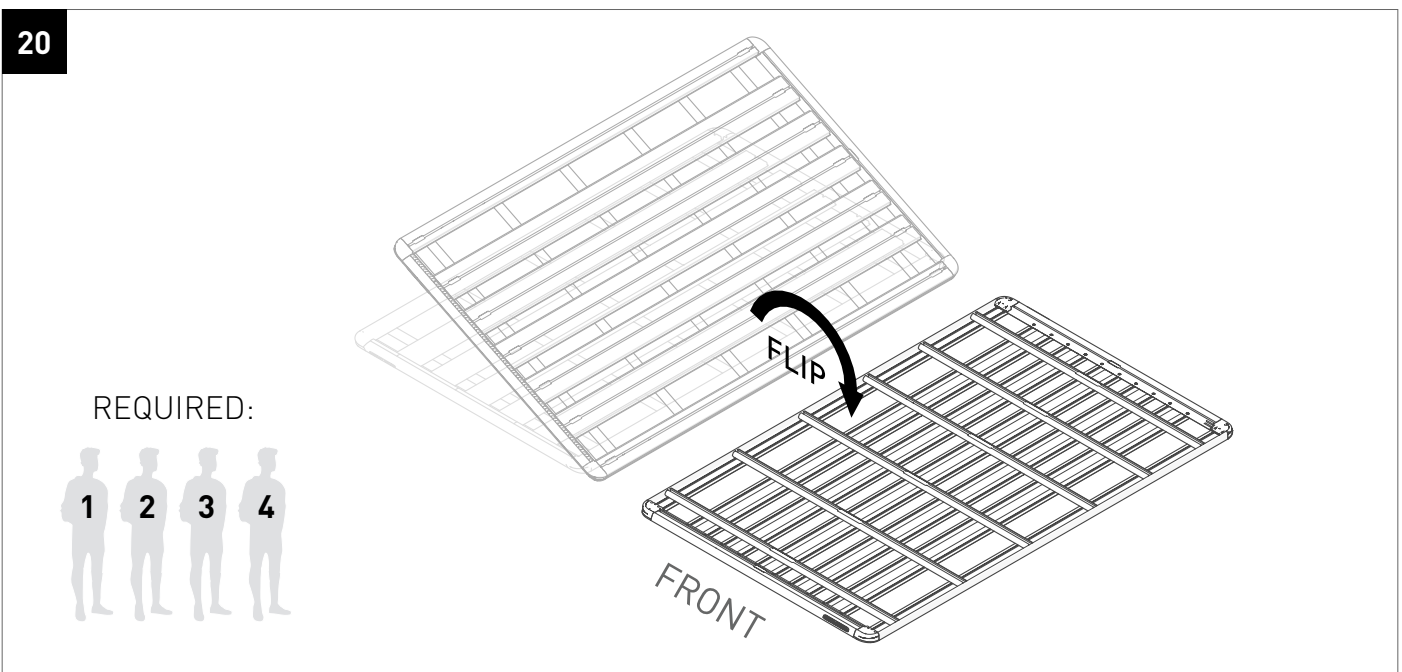
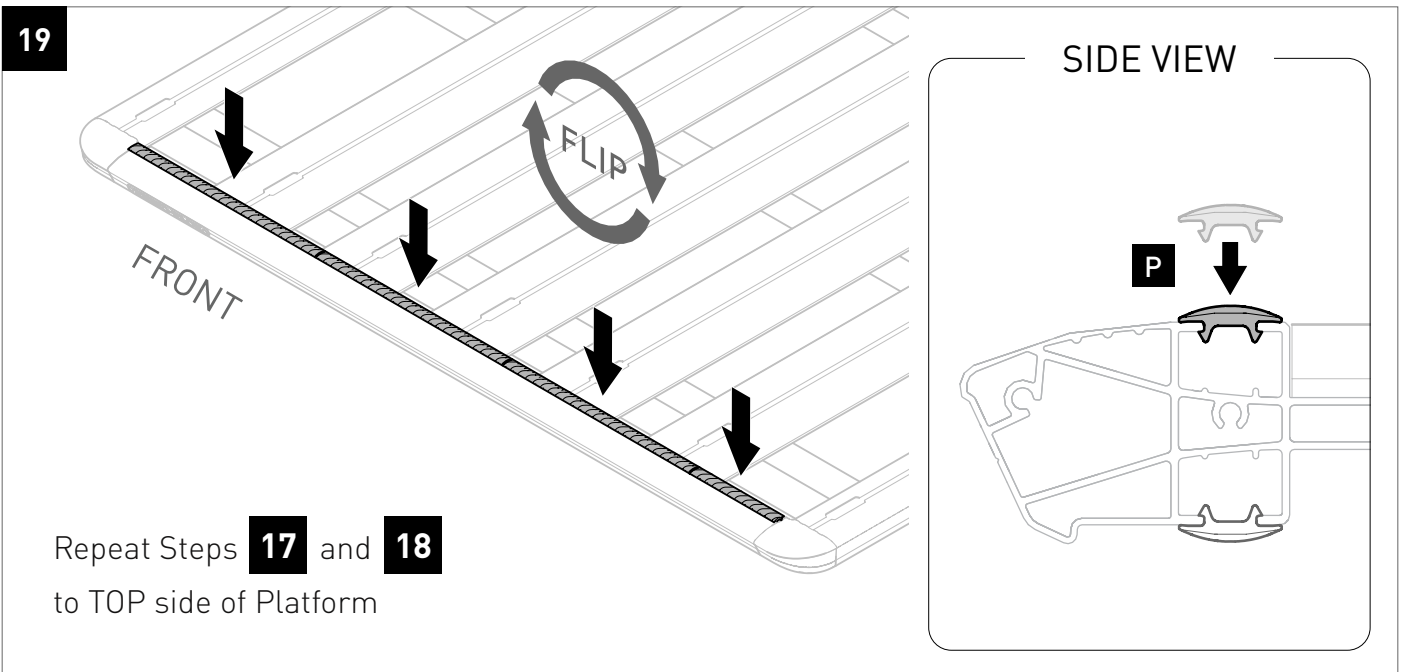
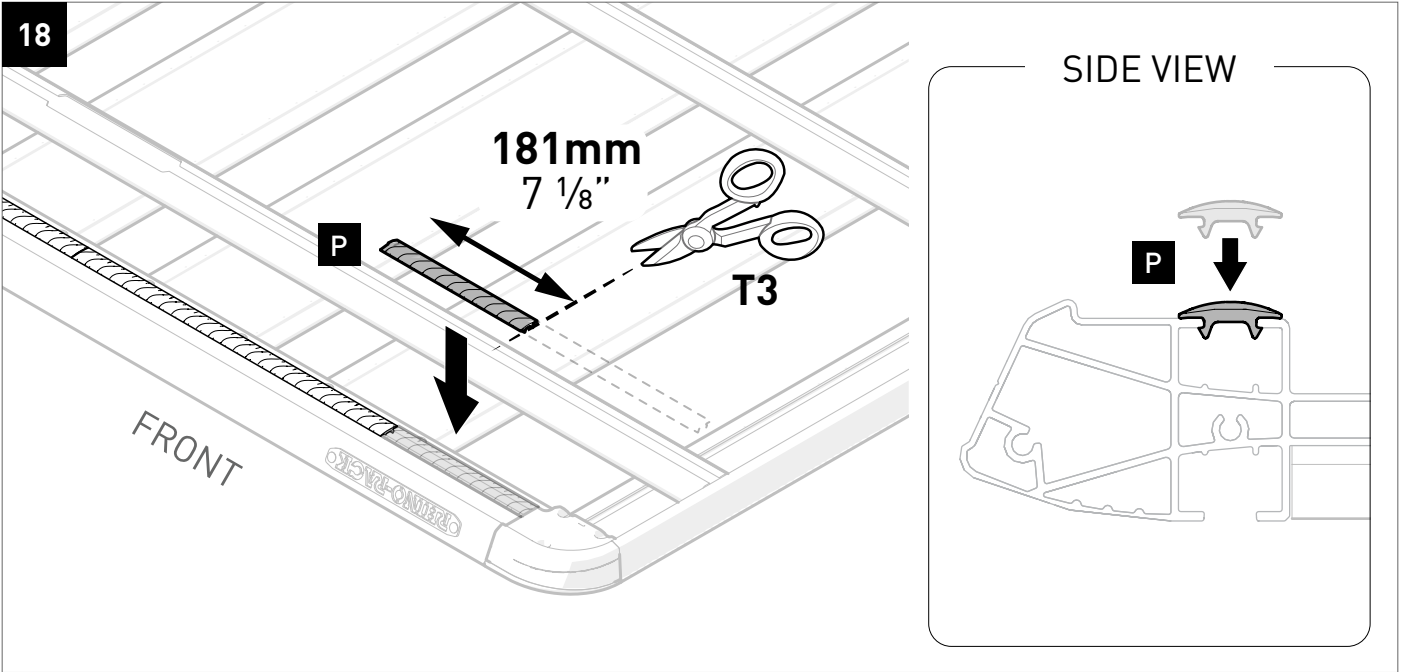

21

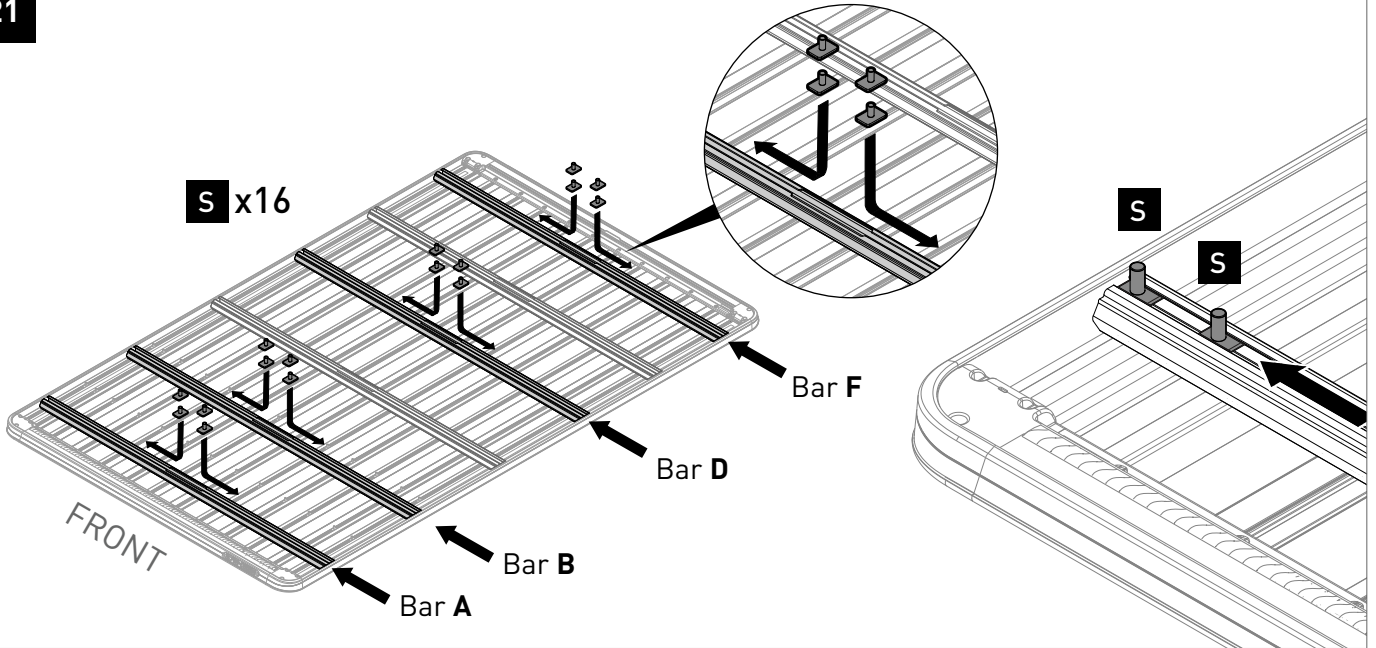

22

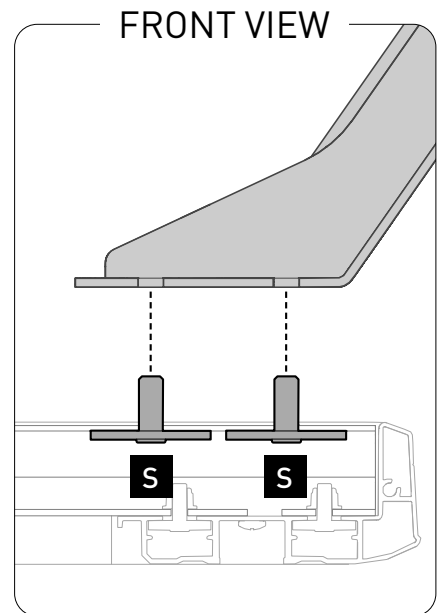
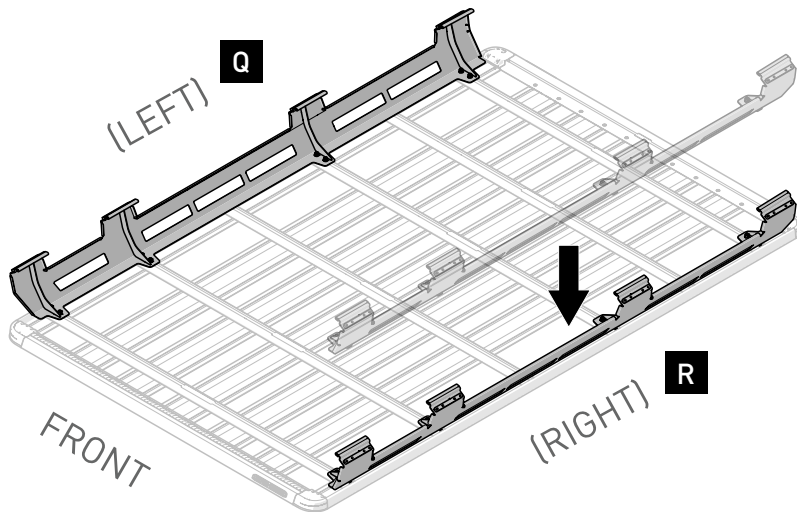

23

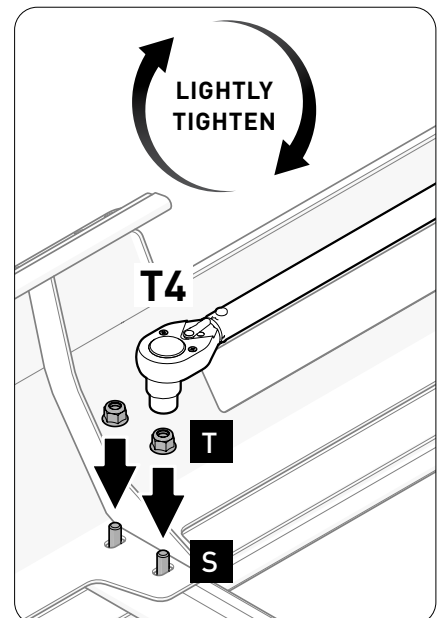
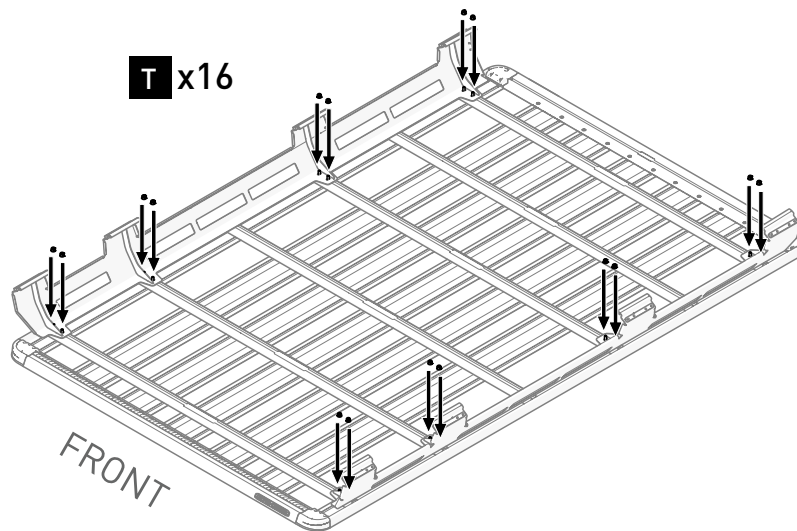

24

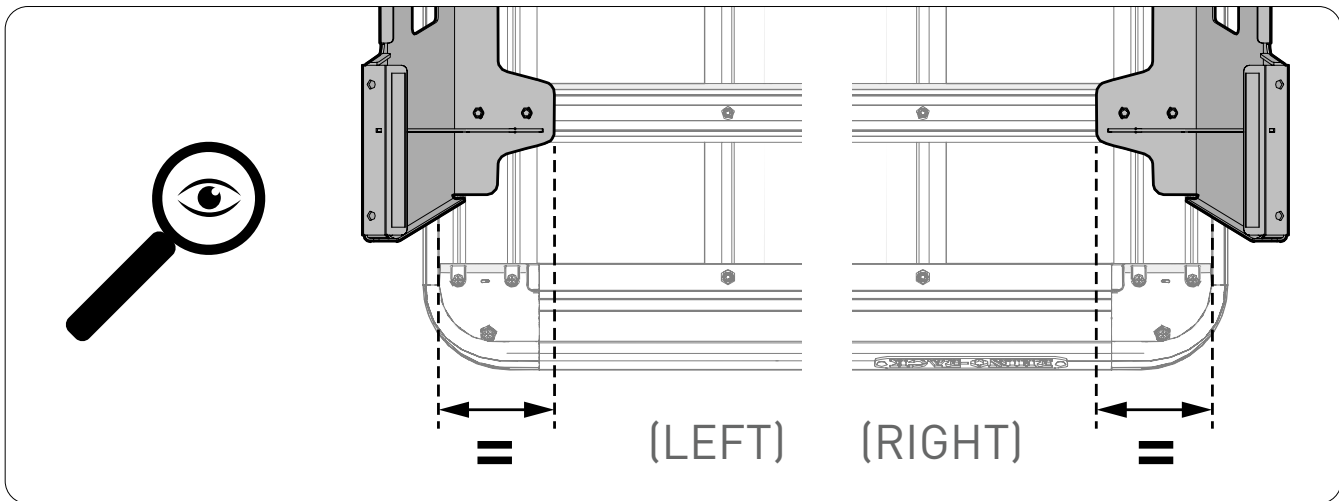
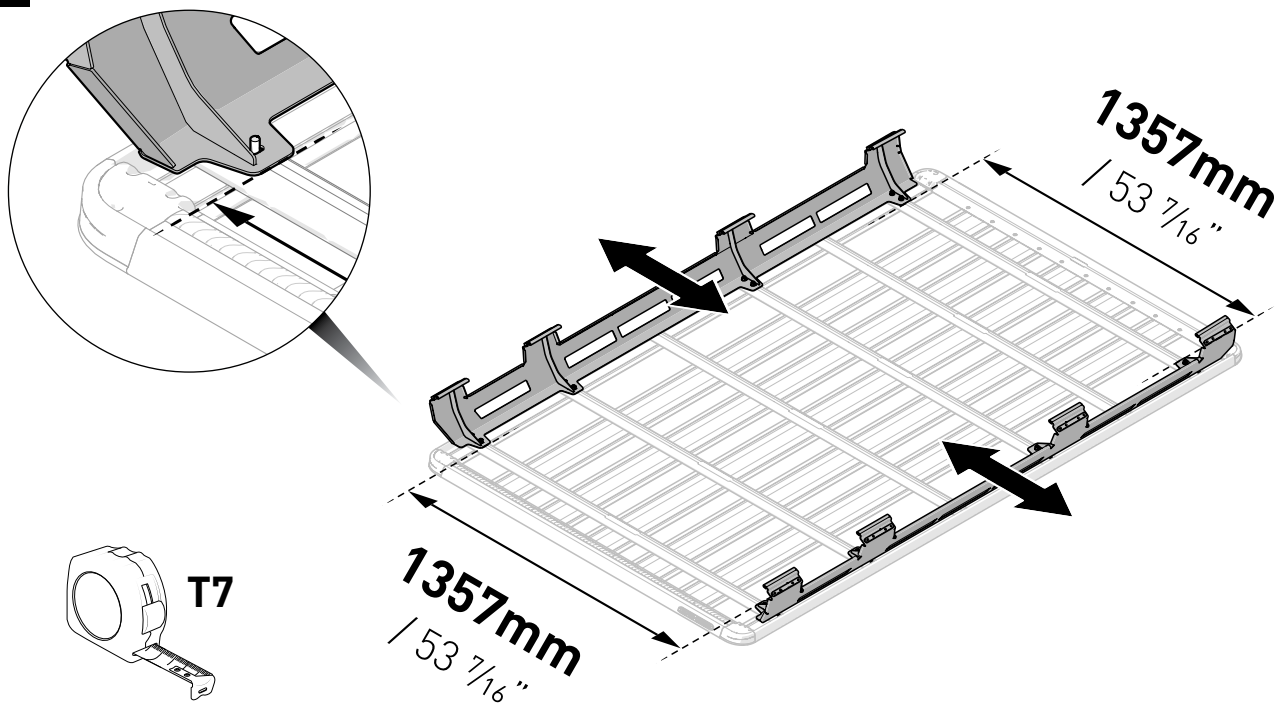

25

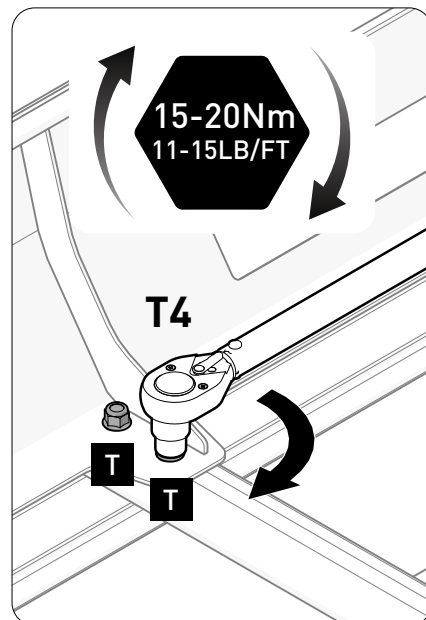
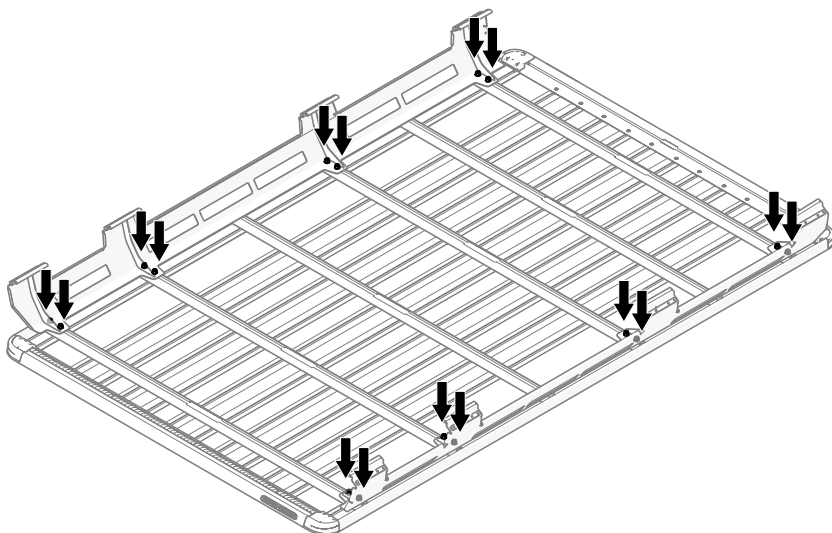

26

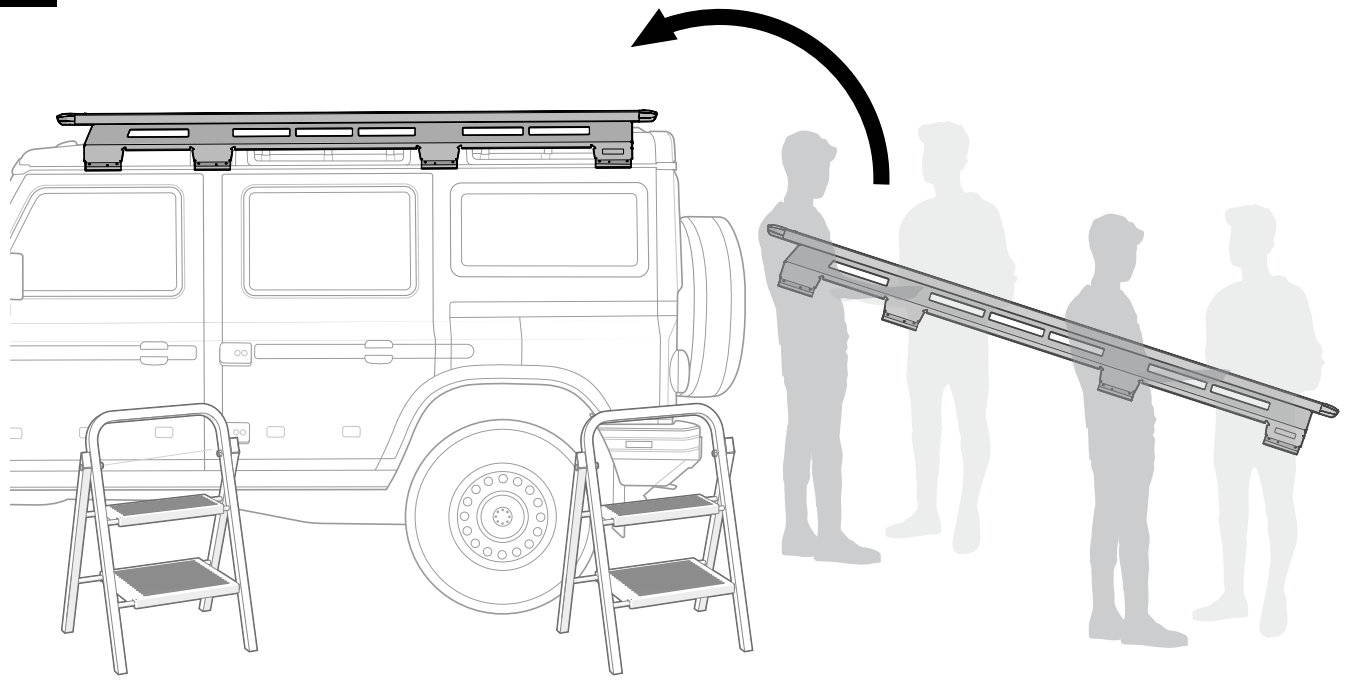

FRONT VIEW

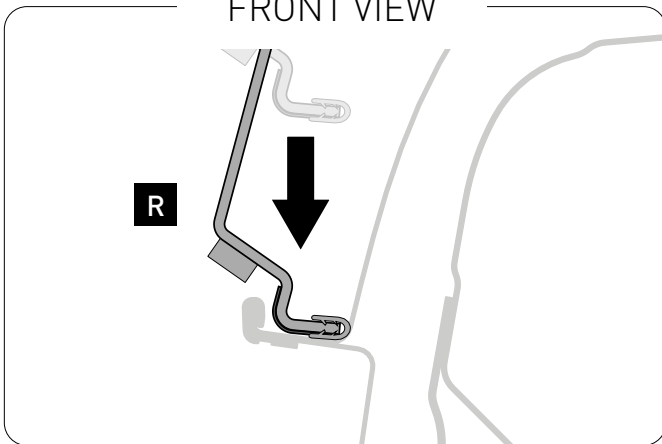

T6x4

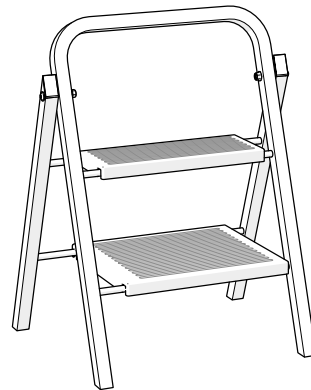

NOTE:
Step ladders must be prepared on each side of the vehicle before placing onto the gutters

27

FRONT

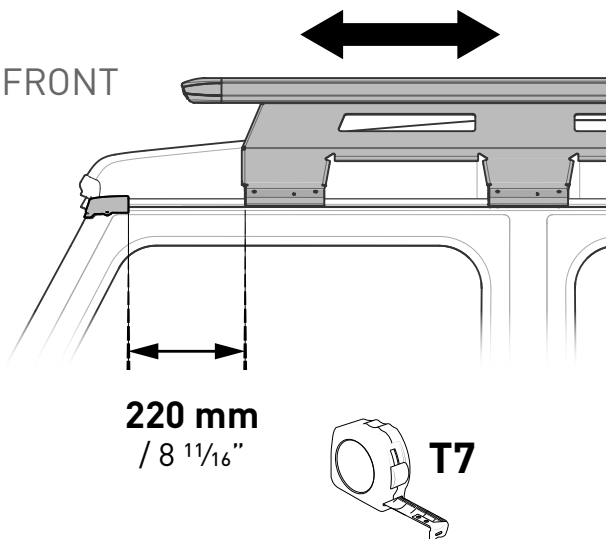

28

FRONT VIEW

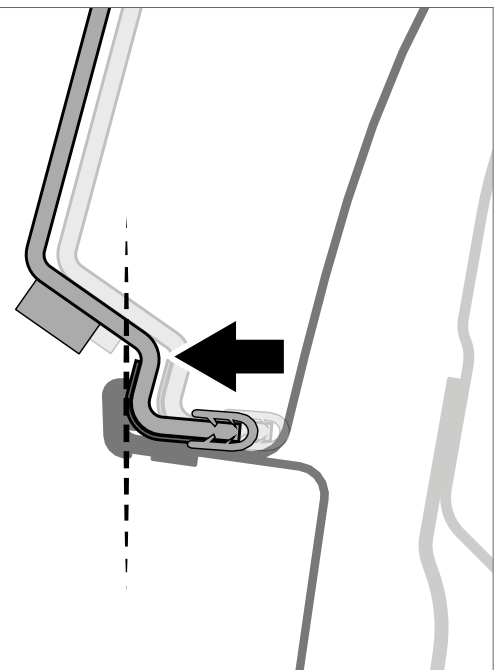

29

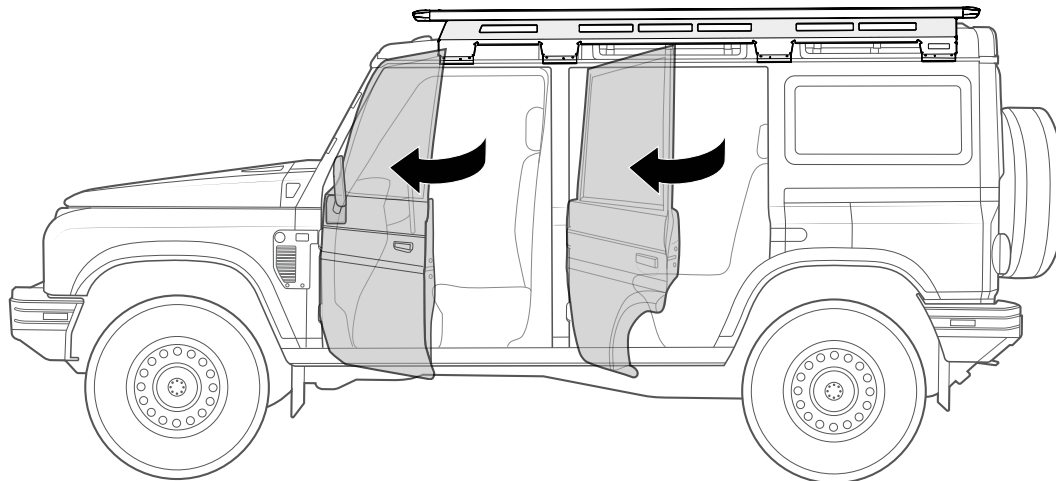

30

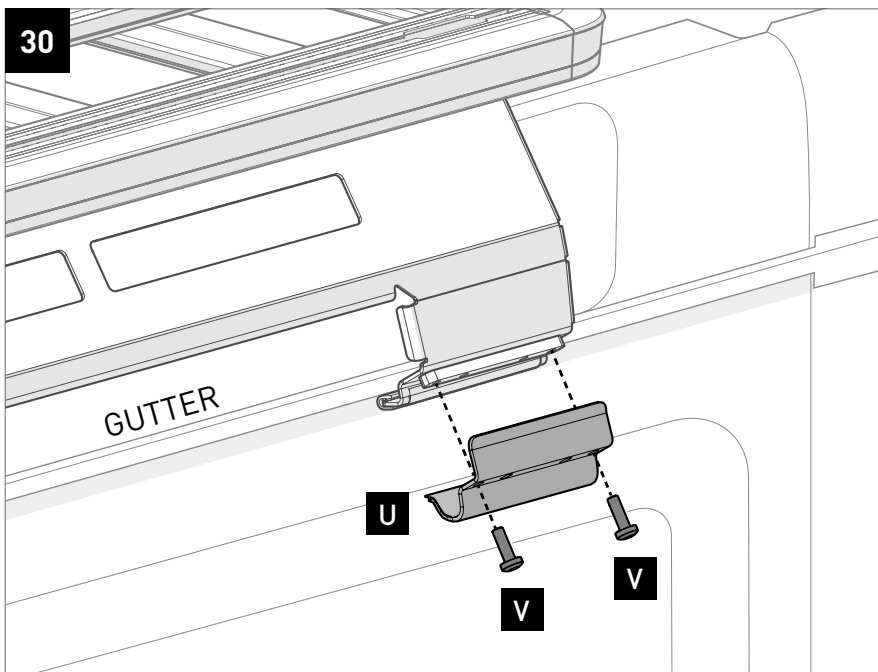

FRONT VIEW

V

T5 **15-17Nm**
11-13LB/FT

Ensure the straps are properly seated.

31

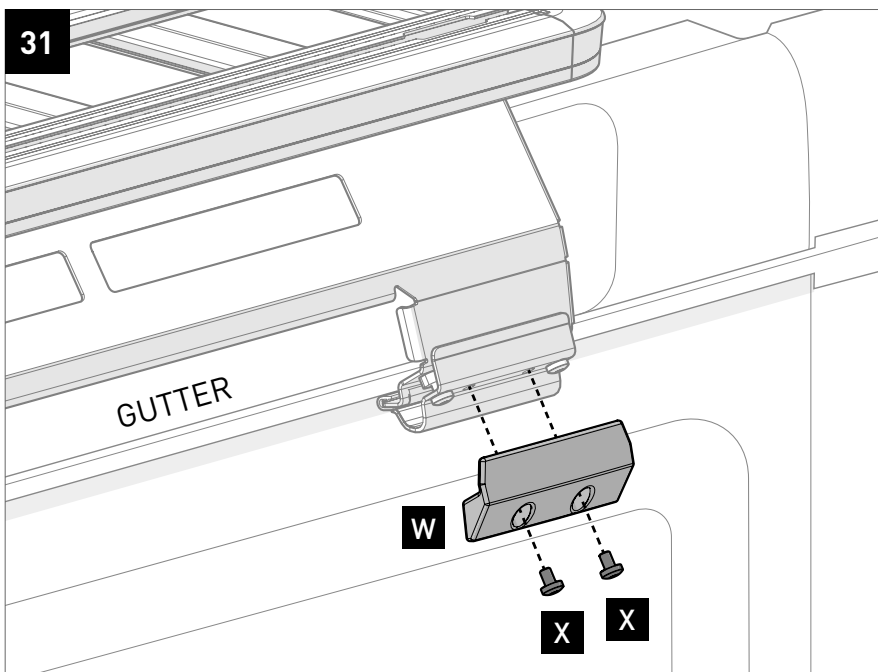

FRONT VIEW

X

T5 **5-7Nm**
3.7-5LB/FT

32

Close doors **carefully** to confirm all straps clear the doors.

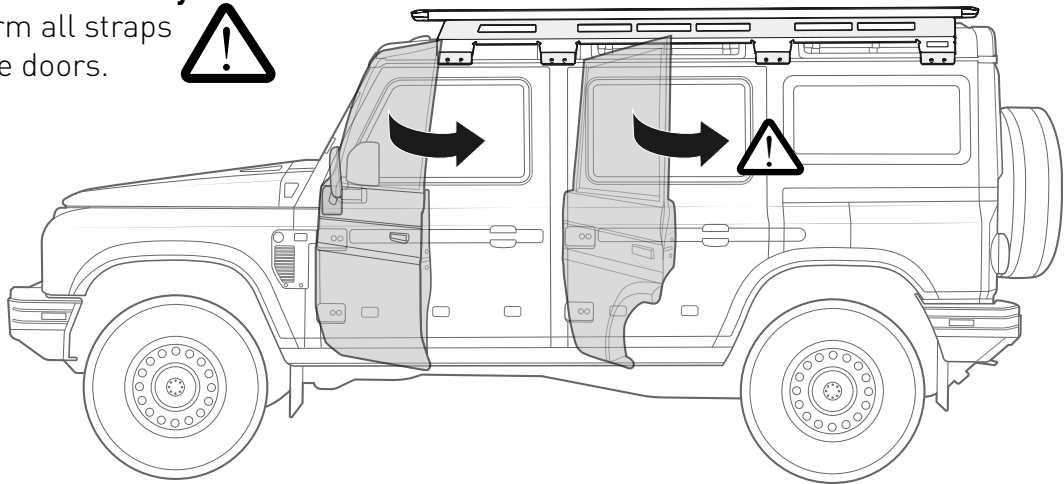

33

Check fitment is secure

