



**INEOS**  

---

**GRE<sup>A</sup>DIER**

# TABLE OF CONTENTS

---

INTRODUCTION AND GENERAL INFORMATION .....	13
OVERVIEW .....	19
BEFORE DRIVING .....	51
DOORS AND WINDOWS .....	57
SEATS, SEAT BELTS, CHILDREN IN CAR SEATS & BOOSTER SEATS, & AIR BAGS .....	65
CARGO LOADING AND SECURING .....	93
DRIVING ON ROAD .....	101
DRIVING OFF ROAD .....	138
TOWING A TRAILER .....	152
TRANSPORTING YOUR GRENADIER .....	157
WINCHES .....	161
MAINTENANCE REPAIRS AND TECHNICAL INFORMATION .....	178
INEOS NEW VEHICLE LIMITED WARRANTIES .....	210

# INTRODUCTION AND GENERAL INFORMATION

---

INTRODUCTION .....	14
FEATURES .....	14
UPDATES .....	14
SYMBOLS IN THIS MANUAL .....	14
GENERAL WARNINGS .....	15
ROLLOVER WARNING .....	16
DATA RECORDING .....	16
REPORTING SAFETY DEFECTS .....	17
ROADSIDE RECOVERY .....	17
CALIFORNIA PROPOSITION 65 .....	17

# INTRODUCTION AND GENERAL INFORMATION

---

## INTRODUCTION

It is important that you read this manual and that the driver and all occupants follow its instructions and precautions as well as all applicable laws and regulations.

## FEATURES

This manual addresses the features that were available for ordering on a 2024 Grenadier for the United States market. Your Grenadier has only the standard features and the features reflected on the invoice that accompanied your Grenadier. The mere fact that a feature is mentioned in this manual does not mean that your Grenadier is so equipped.

Note that software may be updated from time to time. The look and content of the Center Display and Touchscreen in the middle of your dashboard may be different from what is depicted in this manual.

The images in this manual are purely illustrative. They may not accurately depict the exact appearance of your Grenadier.

We reserve the right to make changes in the design and fitment of future vehicles.

## UPDATES

We reserve the right to make changes in the design and fitment of future vehicles.

Note that software in your Grenadier may be updated from time to time. The look and content of the Center Display and Touchscreen in the middle of your dashboard may be different from what is depicted in this manual

This manual may be updated from time to time. For the most current version, see the online Owner's Manual posted on our website at <https://ineosgrenadier.com/en/us/>.

© Copyright INEOS Automotive Americas, LLC, 2023. All Rights Reserved. This publication is provided with your Grenadier for your personal, private, and non-commercial use. Under no circumstances should the content in this Owner's Manual be reproduced in any form or by any means without prior written permission of INEOS Automotive Americas, LLC.

## SYMBOLS IN THIS MANUAL

Everything in this manual is intended to promote the safe use of your Grenadier. You should read and heed the entire manual. However, some information is particularly important and follows certain symbols.



**WARNING:** The **WARNING** symbol, seen throughout, alerts you to particular risks that, if not avoided, could result in serious injury and death. Pay extra attention to the information and precautions that follow this symbol.



**NOTE:** The **NOTE** symbol alerts you to other information of particular importance.

# INTRODUCTION AND GENERAL INFORMATION

---

## GENERAL WARNINGS

These warnings apply generally to any use of your Grenadier. Failure to heed these may result in serious injury and death.



### WARNING:

- > **Obey the law.** Everyone using your Grenadier must comply with all local laws and regulations at all times. They are there for your safety and the safety of others.
- > **Prevent driver inattention and impairment.** Distracted driving (e.g., using a hand-held phone, texting, checking emails, adjusting settings on the Touchscreen) and driving while impaired (e.g., fatigued, drowsy, under the influence of alcohol or drugs) are leading causes of collisions, injury and death. Even a momentary distraction can have disastrous consequences. The driver must pay attention to driving at all times.
- > **Occupants must ride in seats.** Every rider must be in a designated seating position in one of the two rows of seats. No one must ride in another location. Whenever possible, children must be placed in one of the second row seating positions, never the front passenger seat.
- > **Do not leave people or pets unattended in your Grenadier, particularly in warm or cold**

**weather.** Vehicles can quickly get very hot and very cold. Even if the outside temperature is in the 70s and the windows are cracked, the temperature in a vehicle can rapidly reach deadly levels. A child's body temperature rises three to five times faster than an adult's. According to the US Government, a child dies of heat stroke in a hot car every 10 days on average. Never leave a child, a pet, or an older person in a vehicle unattended for any length of time. Rolling windows down or parking in the shade does little to change the interior temperature of the vehicle. Make it a habit to check your entire vehicle — especially the back seat — before locking the doors and walking away. Failure to follow these precautions can result in serious injury and death.

- > **Do not leave children unattended with the keys.** Children can lock themselves in a hot car. They can turn a vehicle on. They can shift it out of gear. They can release the brake. Leaving children unattended with the keys, even for seconds, can lead to serious injury and death.
- > **Obey the instructions, precautions and warnings throughout this manual.** Obeying the warnings, instructions and precautions reduces the risk of serious injury and death, to you and those around you.

# INTRODUCTION AND GENERAL INFORMATION

## ROLLOVER WARNING



**WARNING: Utility vehicles have a significantly higher rollover rate than other types of vehicles.**

Your Grenadier is designed so that it can be driven off-road. It has a higher ground clearance and a higher center of gravity than ordinary passenger cars and many SUVs and crossovers. That increases the risk of overturning. Modifying the vehicle (e.g., oversized tires, lift kits, additional accessories above the bumper level) can further raise the center of gravity and increase the risk of rollover. Certain kinds of loading (e.g., significant weight on the roof, substantial loads in the cargo area, including the quartermaster loadbay, loose heavy cargo) can also increase the risk.

Avoid sharp turns and abrupt maneuvers. If you drift off the road, especially onto an unpaved shoulder, avoid sudden steering or braking. Slow down and return to the pavement gradually and safely.

Avoid traversing slopes. Driving your Grenadier across a slope, particularly an irregular slope, increases the risk of rollover. If you must traverse a slope, remove as much cargo as possible and drive slowly.

As with other vehicles of this type, failure to operate the vehicle correctly may result in rollover.

In a rollover crash, an unbelted person is significantly more likely to die than a person wearing a seat belt.

## DATA RECORDING

This vehicle is equipped with an event data recorder (EDR). The main purpose of an EDR is to record, in certain crash or near crash-like situations, such as an air bag deployment or hitting a road obstacle, data that will assist in understanding how a vehicle's systems performed. The EDR is designed to record data related to vehicle dynamics and safety systems for a short period of time, typically 30 seconds or less.

The EDR in this vehicle is designed to record such data as:

- > How various systems in your vehicle were operating;
- > Whether or not the driver and passenger safety belts were buckled/fastened;
- > How far (if at all) the driver was depressing the accelerator and/or brake pedal; and,
- > How fast the vehicle was traveling.

These data can help provide a better understanding of the circumstances in which crashes and injuries occur.



*NOTE: EDR data are recorded by your vehicle only if a non-trivial crash situation occurs; no data are recorded by the EDR under normal driving conditions and no personal data (e.g., name, gender, age, and crash location) are recorded. However, other parties, such as law enforcement, could combine the EDR data with the type of personally identifying data routinely acquired during a crash investigation.*

## INTRODUCTION AND GENERAL INFORMATION

---

To read data recorded by an EDR, special equipment is required, and access to the vehicle or the EDR is needed. In addition to the vehicle manufacturer, other parties, such as law enforcement, that have the special equipment, can read the information if they have access to the vehicle or the EDR.

Your Grenadier uses Radio Frequency ID (RFID) technology for purposes such as tire pressure monitoring, radio remote controls, and the key remote control for locking and unlocking the doors. INEOS vehicles with RFID do not use or record personal information or exchange information with any other INEOS system containing personal information.

### REPORTING SAFETY DEFECTS

If you believe that your Grenadier has a defect which could cause a crash or could cause injury or death, you should immediately inform the National Highway Traffic Safety Administration (NHTSA) in addition to notifying INEOS.

If NHTSA receives similar complaints, it may open an investigation, and if it finds that a safety defect exists in a group of vehicles, it may

order a recall and remedy campaign. However, NHTSA cannot become involved in individual problems between you, your dealer, or INEOS.

To contact NHTSA, you may call the Vehicle Safety Hotline toll-free at 1-888-327-4236 (TTY: 1-800-424-9153); go to <http://www.safercar.gov>; or write to: Administrator, NHTSA, 400 Seventh Street, SW., Washington, DC 20590. You can also obtain other information about motor vehicle safety from <http://www.safercar.gov>.

### ROADSIDE RECOVERY

INEOS Grenadier Roadside Assistance is available in the USA and Canada 24 hours a day, 365 days a year.

Coverage starts on the original vehicle in-service date and is free-of-charge during the manufacturer warranty period.

For roadside assistance, please call: 866-882-6411. You can also call if you have any questions about covered services, including towing for warranty-related incidents.



## INTRODUCTION AND GENERAL INFORMATION

---

### CALIFORNIA PROPOSITION 65

 **WARNING:** Operating, servicing and maintaining a passenger vehicle or off-highway motor vehicle can expose you to chemicals including engine exhaust, carbon monoxide, phthalates, and lead, which are known to the State of California to cause cancer and birth defects or other reproductive harm. To minimize exposure, avoid breathing exhaust, do not idle the engine except as necessary, service your Grenadier in a well-ventilated area and wear gloves or wash your hands frequently when servicing your Grenadier. For more information go to [www.P65Warnings.ca.gov/passenger-vehicle](http://www.P65Warnings.ca.gov/passenger-vehicle).

 **WARNING:** Batteries, battery posts, terminals, and related accessories contain lead and lead compounds, and other chemicals known to the State of California to cause cancer and birth defects or other reproductive harm. Wash hands after handling.

 **WARNING:** This product can expose you to chemicals including cadmium, which is known to the State of California to cause birth defects or other reproductive harm. For more information go to [www.P65Warnings.ca.gov](http://www.P65Warnings.ca.gov).

# OVERVIEW

---

INTRODUCTION .....	20
KEYS .....	21
CENTER DISPLAY AND TOUCHSCREEN .....	23
CENTRAL CONTROL INTERFACE (CCI) .....	28
CENTER CONTROL PANEL .....	29
OVERHEAD CONTROL PANEL .....	32
TELLTALE CLUSTER .....	34
STEERING WHEEL CONTROLS .....	37
COMPASS WITH ALTIMETER (if equipped) .....	38
FORWARD AND REAR LAMPS .....	38
INTERIOR LAMPS .....	44
OTHER CONTROLS .....	47
DRIVING CONTROLS .....	50
FUSE PANELS AND BATTERIES .....	50

# OVERVIEW

## INTRODUCTION

This section gives you an overview of the Grenadier, its keys, its interior controls and its exterior.

The interior of your Grenadier has a familiar layout in some respects but perhaps not in others. The screen immediately behind the steering wheel is a Tell-tale Cluster where warning and status lights illuminate. The Center Display and Touchscreen in the center of the dash is where vehicle speed, fuel levels and the like are displayed. The Center Control Panel, just below the center air vents, has climate and other controls. There is also an Overhead Control Panel on the underside of the roof, above and between the two front seats.

Be sure to read this manual and be fully familiar with the layout and controls before driving. The driver must not be searching for controls

or signals while driving. That could lead to a loss of control, an accident, and to serious injury and death.

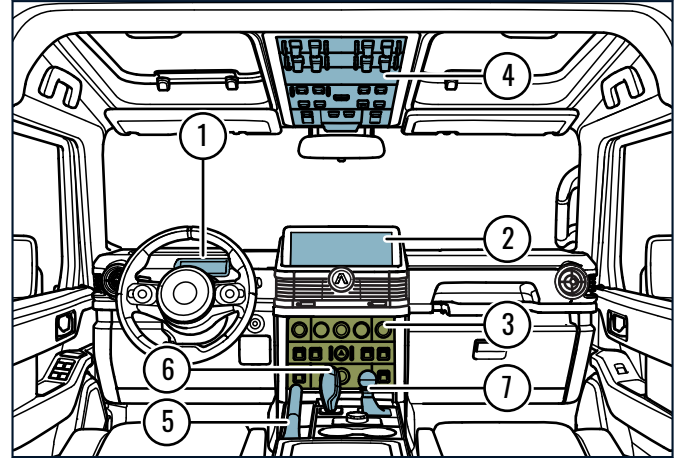

(1) Telltale Cluster	(3) Center Control Panel	(6) Gear Shift
(2) Center Display and Touchscreen	(4) Overhead Control Panel	(7) Transfer Case Shift
	(5) Parking Brake	(8) Center Console

# OVERVIEW

## KEYS

### Introduction

Your key has a retractable blade for starting the engine and manually locking/unlocking the doors. It also has an electronic remote control for unlocking, locking, and alarms.

The key's remote control might not work if:

- > The key is too far from your Grenadier.
- > Either your Grenadier or key battery is dead.
- > Nearby devices interfere with its function.

The key's range varies with environmental factors. Other devices, including mobile phones and medical equipment, might use the same radio frequencies as the key, potentially affecting its operation.

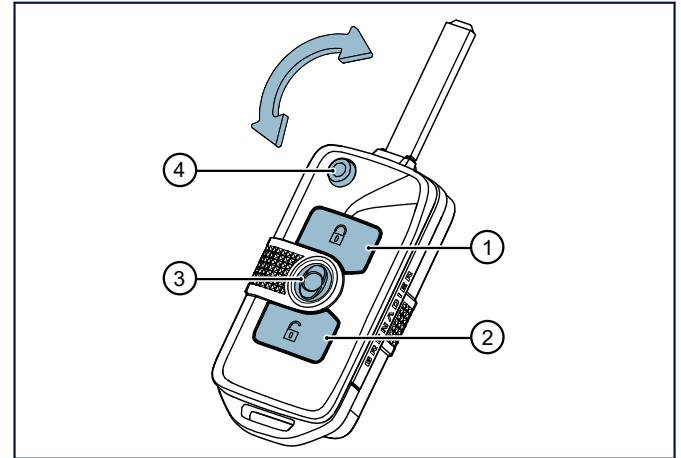

1. Lock Button
2. Unlock Button
3. Panic Button
4. Key Blade Release

# OVERVIEW

---

## Using your key

To unlock doors:

- > Press and release the Lock Button once to unlock only the driver's door. The headlights will turn on for a short period of time to illuminate the space ahead. Exterior lights will flash briefly to confirm your Grenadier's doors have locked.
- > Press the Unlock Button twice to unlock all doors including the rear. The lights will react the same way.
- > Or insert the Key Blade into the driver's lock to unlock all doors.

To lock doors:

- > Press and release Lock button to lock all doors, including the rear, and arm the security system. Exterior lights will flash briefly.
- > Or insert the Key Blade into the driver's lock to lock all doors. Note that the alarm system will not activate unless all doors are locked.

To use the Panic Button:

- > Press the Panic button once to activate. You need not keep it pressed. The horn will sound, and exterior lights will flash for three minutes.
- > Press any button or switch the ignition on to turn the panic alarm off.

To expose the Key Blade, press the Key Blade button on the key housing. The key blade will spring out and lock in the extended position.

To put the Key Blade back into the housing, press and hold the Key Blade button while gently pressing the key blade edge to pivot it back inside.

## Anti-theft immobilizer

Your Grenadier has a passive anti-theft immobilizer system and will start only with the special keys provided. Each key contains an electronic chip. The lock works both as a standard lock and a communicator, syncing with the key's electronics. The ignition, fuel, and starter only activate with an "authorized" key.

## Replacement keys

You can purchase replacement keys from an INEOS dealer. An INEOS dealer can program replacement keys to work with your Grenadier.

## Key battery replacement

Your Grenadier key is battery powered. If you find that its electronic functions are not working or its range is reduced, replace the battery.

Changing the battery won't affect the key's programming. It will continue to work with your Grenadier.



The key requires one coin-type 3-volt lithium battery type CR2032 or equivalent.

# OVERVIEW

To replace the battery:

- > Insert a small flat head screwdriver into the slot on the end of the housing opposite the Key Blade and pry the housing apart.
- > Remove the white plastic battery cover.
- > Remove the old battery.
- > Insert a new battery with the positive (+) side up
- > Refit the white plastic battery cover.
- > Secure the two parts of the housing back together.
- > Test to see that the Key's remote controls are working.
- > Properly recycle used batteries. Don't dispose of them in regular trash. Follow environmental guidelines for disposal.

## Key-related warnings

-  **WARNING: Never leave children or pets alone in a vehicle or leave children with access to an unlocked vehicle or key. Always remove the key when exiting.**
-  **WARNING: Keep batteries away from children. If swallowed, batteries can cause serious injuries within two hours that can lead to serious injury and death. If you suspect that a battery may have been ingested, seek medical attention immediately.**



**WARNING: If the key's cover isn't secure, stop using it, keep it away from children, and have it repaired or replaced by your INEOS dealer.**



**WARNING: Avoid exposing the key to extreme heat, dust, humidity, or direct sunlight. Keep it away from liquids.**

## FCC notice

This device complies with Part 15 of the FCC Rules. Operation is subject to the following two conditions: (1) This device may not cause harmful interference, and (2) This device must accept any interference received, including interference that may cause undesired operation.

Changes or modifications not expressly approved by the party responsible for compliance could void the user's authority to operate the equipment.

## CENTER DISPLAY AND TOUCHSCREEN

Always prioritize safe driving. Avoid using the Center Display and Touchscreen functions that might distract you while driving. Only adjust settings when your Grenadier is stationary.

## Introduction

The Center Display and Touchscreen contains your Grenadier's computerized, electronic controls and many of your Grenadier's

# OVERVIEW

displays. It automatically turns on when the ignition switch is turned to Accessory (ACC) or On.

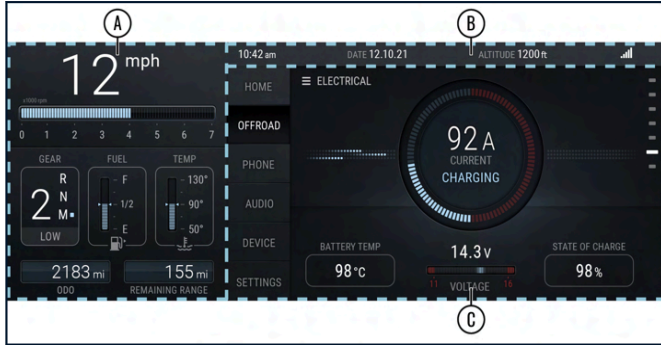

When the transmission is shifted to R (Reverse), an image from the rear backup camera is displayed on the Center Display and Touchscreen.

The Center Display and Touchscreen is broadly divided into three regions.

The Instrument Panel (A): displays the standard information required for operating your Grenadier that would traditionally be shown in a physical gauge cluster, including vehicle speed, engine speed, gearshift position, transfer case range, fuel level, engine coolant temperature, an odometer, and a fuel range estimate.

The Info Bar (B): is at the top of the screen. It displays context-specific information:



The Info Bar displays the current time, date, altitude, and phone signal strength for a connected phone.

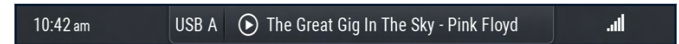

The audio overlay will appear if audio is playing and the AUDIO tab is not selected.

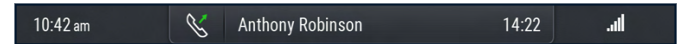

Active phone call overlay will appear while you are on a call and the PHONE tab is not selected.

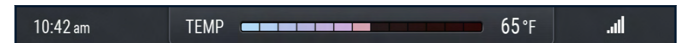

The temperature overlay will appear as you adjust the climate controls.



# OVERVIEW

---

The volume overlay will appear when you adjust the audio volume.

The Tabs Panel (C): shows the content for the selected tab. There are six tabs to choose from.

## Home

The Home tab is divided into two sections:

- > The upper section shows audio information such as the currently playing and upcoming tracks in a playlist, the selected radio station, or SiriusXM content.
- > The lower section shows a list of favorite contacts from a connected phone.

## Offroad

The Offroad tab displays a menu of features useful for driving off-road. Selectable displays on this tab include:

- > Attitude: wheel angle, altitude, g-force, pitch, and roll.
- > Temperature: tire pressures and tire, automatic transmission, and transfer case temperatures.
- > Pathfinder mode: this display has navigational sub-displays RECORD PATH and FOLLOW PATH for collecting or following waypoints, and ROADBOOK for tracking distances while navigating with a roadbook.
- > Statistics: shows statistics for the current trip, including current location (latitude/longitude), altitude, travel time and distance, average speed, and average fuel economy.

- > Electrical: shows current charge, battery temperature, voltage, and state of charge.

## Phone

The Phone tab displays features of a connected phone. It shows your phone's contact list, allowing you to search by name and make calls. You can also add favorite contacts to your HOME tab for faster access. The tab provides a history of recent calls and offers options for dialing, accepting or rejecting calls, and handling ongoing calls.

## Audio

The audio tab lets you select and play audio from different sources, including:

- > Apple CarPlay.
- > Android Auto.
- > Radio.
- > SiriusXM.
- > USB connected devices such as phone or storage devices.
- > Bluetooth devices such as a phone tablet.

## Device

The Device Tab shows phones that have been connected. The device tab will rename to Apple Carplay or Android Auto if your phone is connected and supports it.



# OVERVIEW

## Settings

The Settings tab displays settings for various functions, including your Grenadier's Advanced Driver Assistance Systems (ADAS). Those are discussed in the ADAS subsection of the Driving On Road section that follows.

You can connect new phones using the Device tab.

## Connecting your phone or tablet



### To connect a phone or tablet with Bluetooth:

If no devices are currently connected,

- > Click on the DEVICE tab to go directly to the settings page.
- > Select 'Connect New Phone'.

Otherwise,

- > Select the SETTINGS tab.
- > Select the COMMUNICATION menu.
- > Select DEVICE.
- > Select 'Connect New Phone'.

Bluetooth discovery will start and show a list of available phones nearby. Select your phone and follow the on-screen instructions to finish the setup.

### To connect a device with a USB cable:

USB ports are located inside the Center Storage Tray or the Center Storage Box (if equipped), identified by the  symbol on the cap cover. There are two types of USB port, one type A and one type C port. Both USB ports transfer data with the USB 2.0 protocol and data connection to the head unit and provide power according to the USB BC 1.2 charging standard to the connected USB device.

Additional USB ports are located on the rear of the Center Console (the horizontal console between the front seats) for the convenience of second row occupants. These ports are for charging devices like mobile phones and are not connected to the Center Display and Touchscreen.

## Connecting Apple CarPlay

After connecting your phone or tablet using Bluetooth, Apple CarPlay will be displayed automatically. If the phone is being connected for the first time, follow the instructions on the Center Display and

# OVERVIEW

---

Touchscreen and/or your Apple CarPlay device screen to finish the setup. Apple CarPlay requires iOS 13 and above. Your CarPlay device must have Hotspot turned on for wireless Apple CarPlay to work.

The DEVICE tab on the Center Display and Touchscreen will change to APPLE CARPLAY, confirming that setup is complete.

## Connecting Android Auto

After connecting your phone or tablet using Bluetooth, a message will be displayed on the Center Display and Touchscreen directing you to follow instructions displayed on your Android Auto device's screen.

1. Follow the instructions shown on your Android device.
2. Click the OK button on the Center Display and Touchscreen.

The DEVICE tab on the Center Display and Touchscreen will change to an Android Auto symbol, confirming that setup is complete.

## Sirius XM

SiriusXM is front row access to the widest variety of entertainment anywhere. Listen in your car to channels including expertly curated ad-free music, plus premium sports coverage with live play-by-play from every major sport, original talk channels including Howard Stern, exclusive comedy, news covering every angle and more. Experience even more on the SXM App including the best collection of podcasts curated for you, Xtra channels of music to fit any mood or activity, Personalized Pandora stations, SiriusXM video with shows,

interviews and performances including epic Howard Stern studio moments.

## Center Display and Touch Screen Notices



### NOTE:

- > *The touchscreen might not respond well if used with gloves or if it's wet. Use only your fingers to operate the touchscreen, avoiding sharp objects.*
- > *Prolonged use of the Center Display and Touchscreen with the engine off can drain your Grenadier's battery.*

## Center Display and Touchscreen Warnings



### WARNING:

- > Familiarize yourself with the Center Display and Touchscreen and its functions before driving. Learning to use it while driving is dangerous and could lead to an accident and to serious injury and death.
- > Always prioritize safe driving. Avoid using the Center Display and Touchscreen functions that might distract you while driving. Only adjust settings when your Grenadier is stationary.

## OVERVIEW

- > Avoid setting the volume of music or calls too high. It's essential to hear outside noises (horns, sirens, etc.) and be aware of your surroundings.
- > While voice commands can reduce distractions, avoid using them in complex traffic situations or when they can divert your attention. Anything that diverts your attention and brain power from driving increases the risk of an accident and of serious injury and death.

### CENTRAL CONTROL INTERFACE (CCI)

On the Center Console just rearward of the shift levers is a rotary knob with surrounding buttons. This is another means of controlling the Center Display and Touchscreen.

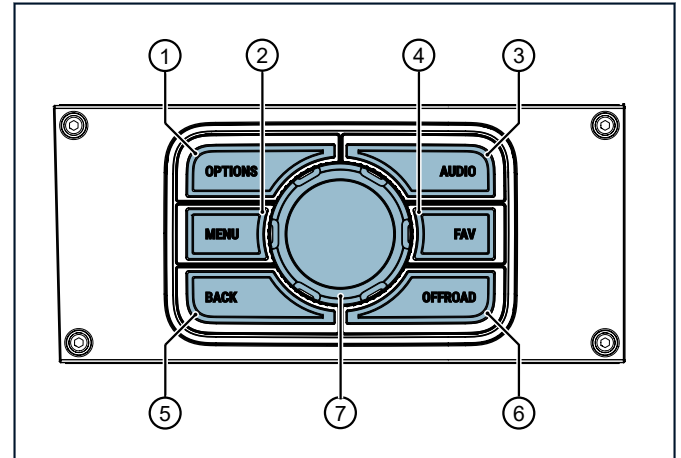

1. OPTIONS. Opens/closes the option menu of the active tab.
2. MENU. Opens/closes the menu of the active tab.
3. AUDIO. Opens the AUDIO tab.
4. FAVORITE. Switches to radio by default; can be changed in the SETTINGS tab.

# OVERVIEW

5. BACK. Returns to previous option or screen.
6. OFFROAD. Opens the OFFROAD tab.
7. Rotary Controller.
  - > Pushing the knob side-to-side or up-and-down moves an onscreen cursor.
  - > Rotating the knob scrolls through options.
  - > Pressing the rotary knob like a button confirms a selection.

## CENTER CONTROL PANEL

This is located on the vertical center panel of the instrument panel.

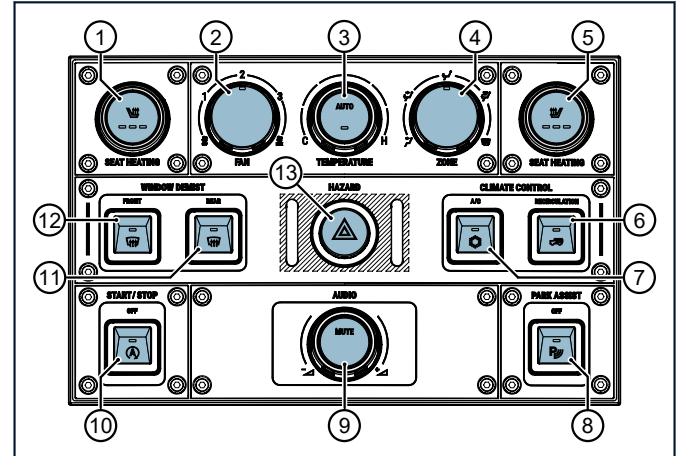

1. Heated front seat (if equipped), driver.
2. Fan speed.
3. Temperature setting and automatic.
4. Air flow selector.
5. Heated front seat (if equipped), passenger.
6. Air recirculation.

# OVERVIEW

---

7. Air conditioning.
8. Park assist.
9. Volume.
10. ECO Start/Stop.
11. Rear defroster, power heated exterior mirrors (if equipped), and heated windshield washer jets (if equipped).
12. Windshield defrost.
13. Hazard warning lamps.

## Fan Speed Settings

Rotate the fan speed knob (2), on the Center Control Panel, clockwise to increase the fan speed and anti-clockwise to decrease the fan speed.

## Temperature and auto settings

Rotate the temperature knob (3), on the Center Control Panel, clockwise to increase the temperature and anti-clockwise to decrease the temperature.

Press the auto button once, to switch on the auto setting. The vehicle will maintain the same temperature by automatically increasing and decreasing the temperature of the air coming through the air vents.

## Air flow zones

Rotate the air flow zone knob (4), on the Center Control Panel, to select the preferred air vents to distribute air flow into the vehicle.

## Recirculation

Press button (6) on the Center Console, to recirculate the air inside the vehicle.

## Air Conditioning

Press button (7) on the Center Control Panel, to switch on the air conditioning. This will activate the air conditioning to distribute cold air inside the vehicle.

## Window defroster rear

Press button (11) on the Center Control Panel, to switch on the window defrost rear feature. This will defrost the rear window for clear visibility. Press a second time to switch off the window defrost rear.

## Window defroster front

Press button (12) on the Center Control Panel, to switch on the window defrost front feature. This will defrost the front window for clear visibility. Press a second time to switch off the window defrost front.

## OVERVIEW

### Vent adjustment

To Adjust the air vents, use the vent knob. Push up or down to adjust the blades inside the vent. Push left or right to adjust the angle of the vent unit. Rotate the knob to open or close the vent.

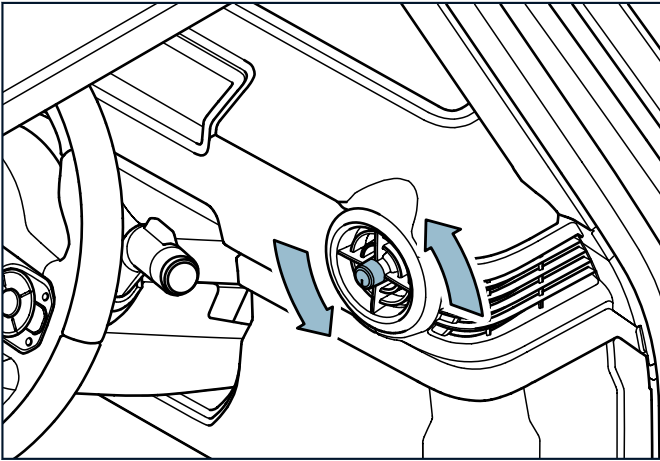

### Heated Front Seats (if equipped)

Independently controlled heated front seats with three temperature settings for both the driver and front passenger.

Press either or both buttons (1) and (5) on the Center Control Panel, to cycle the seat heating level on the front seats. The LEDs show which heating level is set, where the higher the number of LEDs illuminated, the greater the heating level.



### WARNING:

- > Be especially cautious when using heated seats with children, the elderly, or individuals with reduced sensitivity to heat. Their skin may be more susceptible to burns and they may have diminished ability to communicate.
- > Do not re-activate the heated seats directly after the auto timer has switched off the heated seats. Re-activating the heated seats repeatedly can cause the seat to become very hot and can cause burn injuries to persons with limited sensitivity to temperature changes.
- > Do not place any heavy items on the seats, pressure on one area of the seat can result in damage to the heating elements. Do not kneel on the seats. Kneeling on the seats may damage the heating elements.

### Start/Stop

This is explained in the Driving on Road section.

# OVERVIEW

## Park Assist

This is explained in the Driving on Road section.

## OVERHEAD CONTROL PANEL

The Overhead Control Panel has switches for various electrical and off-road features of your Grenadier. Familiarize yourself with them before you drive your Grenadier. With the exception of an interior

lamp, you will probably never operate any of these switches while in motion on a paved road.

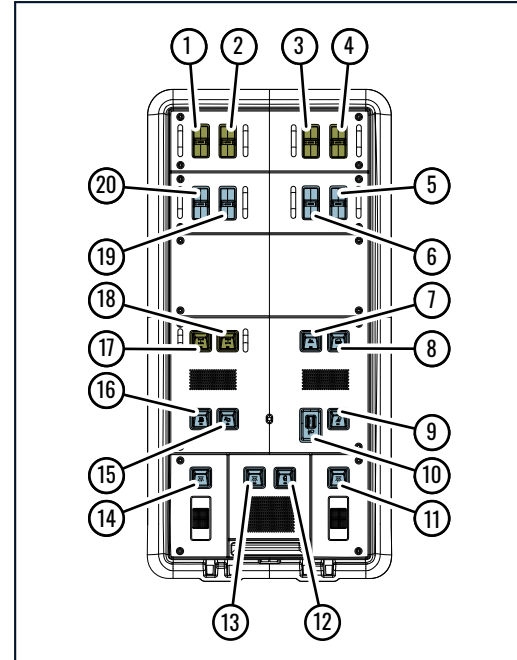

1. EXT 2: If equipped – Switch on or off 25A circuit A (front right roof outlet), of the exterior roof power outlets.
2. EXT 3: If equipped – Switch on or off 25A circuit B (front left,

## OVERVIEW

---

- rear left, and rear right roof outlet), of the exterior roof power outlets.
3. EXT 4: If equipped – Switch on or off, the front winch (if equipped) and rear high amp outlet (NATO outlet).
4. EXT 5: If equipped – Switch on or off the 25A under hood power preparation.
5. INT 2 Switch on or off the 10A right footwell power preparation.
6. INT 1 Switch on or off the 10A left footwell power preparation.
7. Off-Road Mode: Activate or Deactivate Off-Road Mode.
8. Wading Mode: Activate or Deactivate Wading Mode.
9. LED Auxiliary High Beam Lights: Switch on or off to prime the LED Auxiliary High Beam Lights. When the main beam is switched on, then the LED Auxiliary High Beam Lights will activate. Off-Road/Wading Mode must be activated.
10. Exterior Head Lights Level: Adjust the level of the Exterior Head Lights.
11. Reading Lamp: Switch on or off, the Reading lamp.
12. Automatic Interior Lamps: Interior Lamps will illuminate when a door is opened.
13. Interior Lamps: Switch on or off the Interior Lamps.
14. Reading Lamp Switch on or off the Reading Lamp.
15. Downhill Assist Activate or Deactivate the Downhill Assist function.
16. ESC OFF: Switch the Electronic Stability Control function off or back on again.
17. Differential Lock Front (if equipped): Activate or Deactivate the Front Differential Lock.
18. Differential Lock Rear (if equipped): Activate or Deactivate the Rear Differential Lock.
19. EXT 1 Switch on or off the 10A under hood power preparation.
20. PWR Switch on vehicle electrical outputs when the ignition is off.



# OVERVIEW

The passenger air bag lamps (A) are located on the forward end of the Overhead Control Panel. (See Seats, Seat Belts, Children in Car Seats and Booster Seats, and Air Bags).

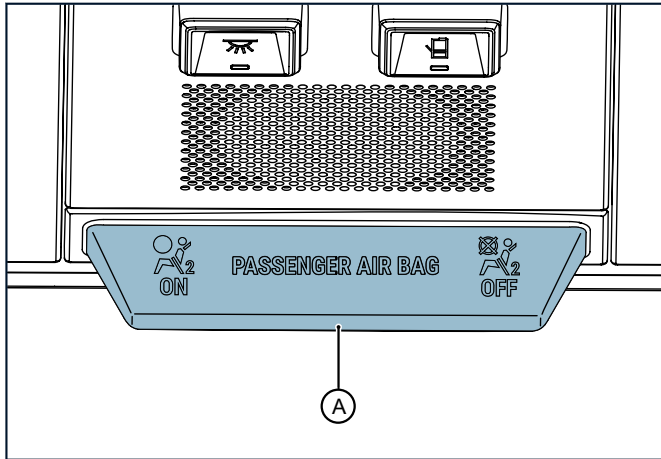

## TELLTALE CLUSTER

The Telltale Cluster is located on a screen behind the steering wheel. The lamps will illuminate when triggered depending on the feature or function they represent. This shows the appearance of the Telltale Cluster when you turn your Grenadier's ignition on. Familiarize yourself with these signals and their meanings as described in the table below. These are for your information, and you must understand their meaning.

The lamp colors give you information about different conditions after the initial Ignition On check and illumination.

LAMP COLOR	MEANING
Green or Blue	The function is activated.
Yellow	There is a condition of which you should be aware.
Red	There is a condition that requires your immediate attention.

**i** *NOTE: If equipped, the Highlight Auxiliary Switch Panel & Electrical Preparation gives another bank of four switches in the Overhead Control Panel and has wiring outlets throughout your Grenadier. The four outlets in the roof rails offer plug-and-play connectivity with additional equipment like the accessory LED light bar. Simply mount the LED light bar run the cable to the outlet and plug in.*

## OVERVIEW

The following gives more specific information. You should consult the relevant sections and subsections of this manual for more information.

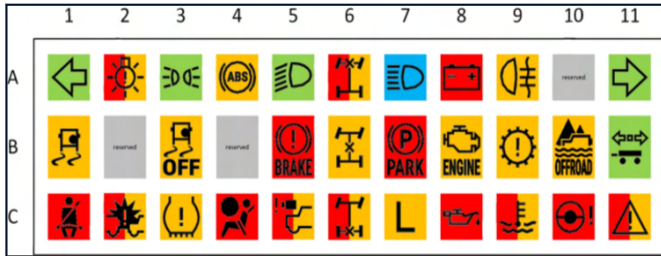

LOCATION	MEANING
A1	Left turn signal on
A11	Right turn signal on
A2	Exterior bulb failure. If you must drive, be aware of this and drive sparingly and accordingly. Consult an INEOS dealer as soon as you can.
A3	Side lamps on

LOCATION	MEANING
A4	Anti-locking brake fault. If you must drive, be aware that this feature is lacking and drive sparingly and accordingly. Consult an INEOS dealer as soon as you can. Will also illuminate if the rear and/or front differentials are locked.
A5	Low beams on
A7	High beams on
A6	Front differential lock engaged
A8	Electrical charge
A9	Rear fog lights
B3	Electronic stability control (ESC) off
B1	ESC fault. If you must drive, be aware that this feature is lacking and drive sparingly and accordingly, particularly on slick roads. Consult an INEOS dealer as soon as you can. Will also blink when actively supporting driver.
B5	Brake system fault. If this is illuminated, do not drive your Grenadier. Have it towed to an INEOS dealer.

## OVERVIEW

LOCATION	MEANING
B7	Parking brake on. Note that this means only that the brake is on enough to trigger the switch. The parking brake lever may not be pulled enough to keep your Grenadier stationary, particularly on slopes and under heavy loads.
B8	Check the engine. If this is illuminated, limit your driving and consult an INEOS dealer as soon as you can. If the lamp is red, stop driving immediately. Park your Grenadier in a safe place and contact an INEOS dealer to have your Grenadier towed there.
B9	Transmission failure - If there is a fault, do not drive your Grenadier and consult with an INEOS dealer.
B11	Trailer turn signal
C1	Seat Belt Warning. Seated front seat passenger and/or driver is unbuckled or rear seat passenger/passengers unbuckled during driving. Please make sure that all passengers are buckled.
C3	Low tire pressure warning. Pull over. Inspect your tires for damage. Adjust your tire pressure to the recommended level.

LOCATION	MEANING
C4	Air bag fault. If you must drive, be aware that this feature is lacking and drive sparingly and accordingly. Consult an INEOS dealer as soon as you can.
B10	Off-road Mode/Wading Mode engaged
B6	Center differential engaged
C6	Rear differential lock engaged
C7	Low gear indication
C8	Engine oil low
C9	Coolant temperature
C10	Steering system failure. If the lamp is illuminated, stop driving immediately. Park your Grenadier in a safe place and contact an INEOS dealer to have your Grenadier towed there.
C11	Overall warning. If the lamp is red, stop driving immediately. Park your Grenadier in a safe place and contact an INEOS dealer to have your Grenadier towed there.

## OVERVIEW

LOCATION	MEANING
C2	Forward Collision Warning. If this is illuminated, there is an error in the system or AEB (Automatic Emergency Braking) has been deactivated by the driver. If the lamp is red, the AEB (Automatic Emergency Braking) system detects possible danger.
C5	Front Camera View warning. If this is illuminated, the camera is obstructed and ADAS systems will not be available.

### STEERING WHEEL CONTROLS

Your steering wheel has controls that allow you to use common features without taking your hands off the wheel. They are shown below. Most will be familiar because they are found in most modern vehicles. The Toot feature may be unfamiliar. It allows you to briefly

sound a warning, particularly for pedestrians and cyclists, that is less “aggressive” than a horn honk.

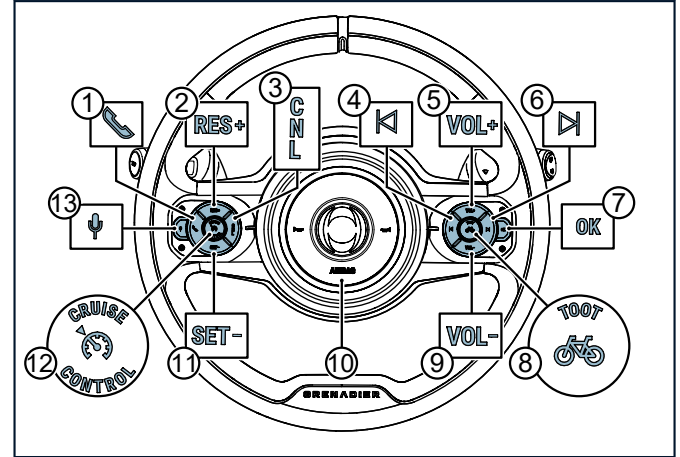

1. Answer calls.
2. Resume speed or increase speed, cruise control and downhill assist.
3. Cancel.
4. Previous track or radio station. Long press: track rewind or radio station change.
5. Volume up.

# OVERVIEW

---

6. Next track or radio station. Long press: track fast forward or radio station change.
7. OK/Confirm.
8. Warning tone for cyclists or pedestrians.
9. Volume down.
10. Main horn.
11. Set speed or decrease speed, cruise control and downhill assist.
12. Cruise control standby or deactivate.
13. Voice activation (Apple CarPlay and Android Auto).

Familiarize yourself with these controls before driving. Do not attempt to get acquainted with them while you are underway.

## COMPASS WITH ALTIMETER (if equipped)

Your Grenadier may be equipped with a compass and altimeter display on a digital LCD display above the Center Console.

## FORWARD AND REAR LAMPS

All external lamps are sealed lamp units with light-emitting diodes (LED) as the light source. The lamp units are not repairable. If a lamp or lamp unit fails, contact your INEOS dealer for a replacement.

## Daytime running lamps

Daytime running lamps increase visibility of your Grenadier during daylight. They are switched on automatically during the daytime when the engine is running. In the United States market, they can be deactivated through the SETTINGS tab.

## Headlamp controls

These are on a stalk to the left of the steering column.

## OVERVIEW

To switch on the low beam, rotate the end of the left lever stalk to position 3. To switch off the low beam, rotate the end of the lever stalk back to the 'OFF' position; Position 1.

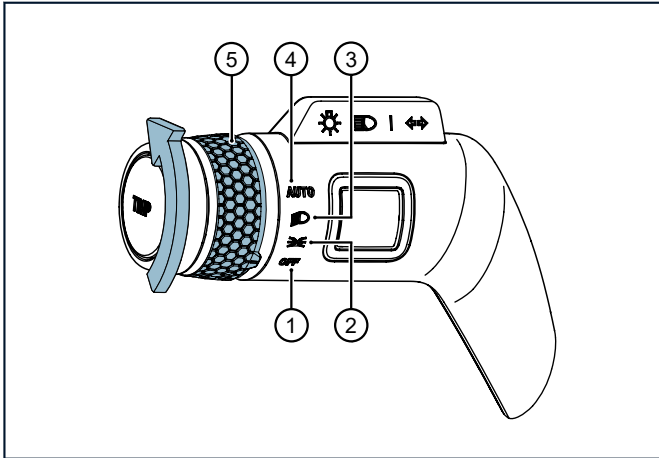

POSITION	STATUS	DESCRIPTION
1	OFF	Low beam lamp functions are switched off.
2	Side Lamps	Side lamps are active.
3	Low Beam	Low beam is activated.

POSITION	STATUS	DESCRIPTION
4	Auto	Switches low beam on automatically when ambient light is low.

### Headlamp auto light control

When the automatic light control function is switched on and the engine is running, the system switches between daytime running lamps and low beam headlamps automatically. This depends on the external lighting conditions and the information given by the sensor system.

When entering and leaving a tunnel for example, the low beam headlamps may automatically turn on if there is minimal lighting. They will turn off again when leaving the tunnel and the sensors detect enough daylight. To switch on the automatic light control function, rotate the end of the left lever stalk to position 4.

The auto light control function turns on front low beams and rear lights, the front and rear side marker lights, and the license plate lamp.

### Headlamp low beams

Low beams are for use at night in areas illuminated by streetlamps, such as towns and cities and low visibility weather conditions, such as in fog, misty, or snowy conditions. Low beams are also required when other vehicles are driving in front of you. The low beams use an asymmetrical beam to illuminate a shorter distance of the road

## OVERVIEW

ahead compared to high beam to avoid the blinding of oncoming vehicles.

### Headlamp high beams

High beams are used to illuminate the way ahead at night when there are no oncoming road users. To switch on the high beams, push the left lever stalk away from the driver, toward the front of your Grenadier. To switch off the high beam pull the lever stalk toward the driver back into the starting position.



**WARNING:** Do not use high beams when oncoming traffic is approaching or when following another vehicle. The light may interfere with the other driver's vision. There is a risk of an accident if the oncoming drivers are temporarily blinded.

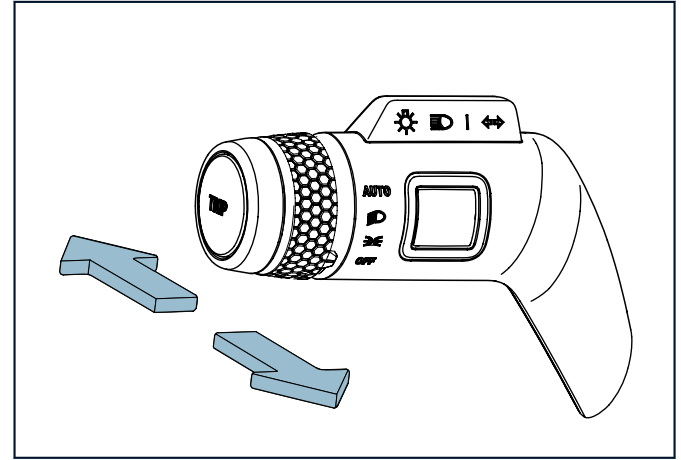

### Headlamp high beam flash

To flash the high beams, pull the left lever stalk toward the driver to activate the headlight and then release back to the starting position to deactivate the headlight. This will result in the headlight flashing on and off once. Repeat for consecutive flashes.

### Headlamp range adjustment

You can adjust the range or your headlamps to account for weight distribution that may cause the front of your Grenadier to pitch higher or lower than normal. Always adjust the headlamps to

# OVERVIEW

maintain adequate illumination of the road and space in front of your Grenadier, without blinding or annoying other drivers and road

users. Turn the thumb wheel  located in the Overhead Control Panel, to the required switch position.

To adjust the headlamps:

1. Park your Grenadier on level ground.
2. Adjust the vertical field of the headlamps according to the load using the thumb wheel.

POSITION	LOAD CONDITION
0	Driver only, or driver and front passenger seats occupied; cargo area empty
1	All seats occupied; cargo area empty
2	All seats occupied by adults; cargo area at maximum
3	Driver only; cargo area at maximum



**WARNING:** It is important to adjust the headlamp range if a heavy load has lowered the back of your Grenadier and thereby raised the head lamp angle. Failure to adjust the headlamp range may temporarily blind other road users resulting in an accident and in serious injury and death. Always restore their position to 0 once your Grenadier is level again.

## Side Marker lamps

Side marker lamps are amber lights on the front corners and red lights on the rear corners of your Grenadier. These can be used when weather (fog, mist, rain, snow) affects visibility. To switch on the side marker lamps, rotate the end of the left lever stalk to position 2. Leaving the side marker lamps on while the engine is switched off will drain the battery.



### WARNING:

- > When the 30/70 rear doors (if equipped) are open, they block a direct view of all rear lights.
- > Never drive with the 30/70 rear doors (if equipped) or either open so far as to cover a tail light.
- > Never open the 30/70 rear doors (if equipped) at night while stopped on a road or trail, even in an emergency.
- > If you must open the 30/70 rear doors (if equipped) when you are near a road or trail, get well off the travel lanes and put out reflective markers or flares before opening either door.
- > Failure to heed these warnings could lead to someone hitting your Grenadier or people behind it, resulting in an accident, leg amputation(s), other serious injuries and death.



# OVERVIEW

## Turn signals

To briefly signal, push the left lever stalk upward or downward and release. To indicate continuously push the left lever stalk upward or downward, until the left lever stalk latches into position, giving a turn signal. To cancel, move the lever stalk back to the starting position.

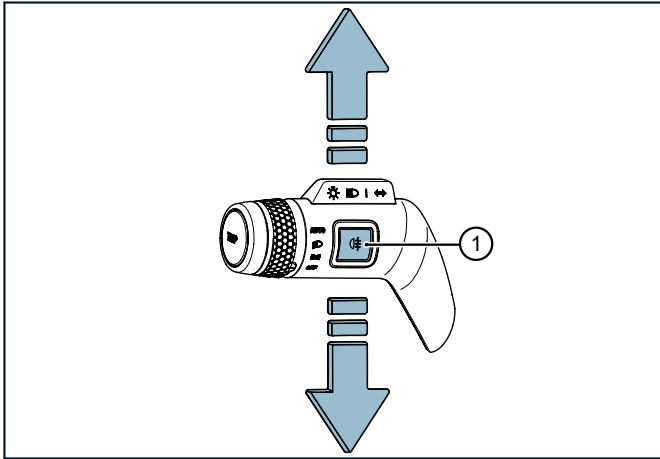

## Hazard signal

Press the hazard warning lamp button, located on the Center Control panel, to activate the hazard warning lamps. When the hazard

warning lamps are switched on, all direction indicator signals will flash. Press the button again, to switch the hazard warning lamps off.



*NOTE: When the ignition is switched off, the hazard warning lamps will continue to operate.*

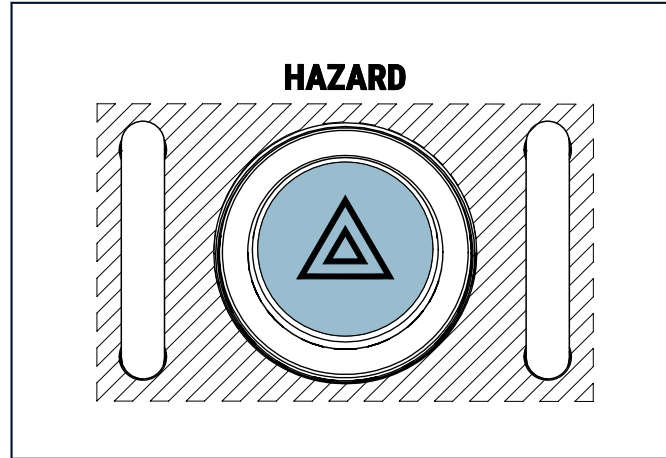

# OVERVIEW



## WARNING:

- > *When the 30/70 rear doors (if equipped) are open, they block a direct view of all rear lights, including the hazard lights.*
- > *Never open the 30/70 rear doors (if equipped) at night while stopped on a road or trail, even in an emergency.*
- > *If you must open the 30/70 rear doors (if equipped) when you are near a road or trail, get well off the travel lanes and put out reflective markers or flares before opening either door.*
- > *Failure to heed these warnings could lead to someone hitting your Grenadier or people behind it, resulting in an accident, leg amputation(s), other serious injuries and death.*

## Rear fog lights

The rear fog lights  are operated by pressing button (1) on the stalk.

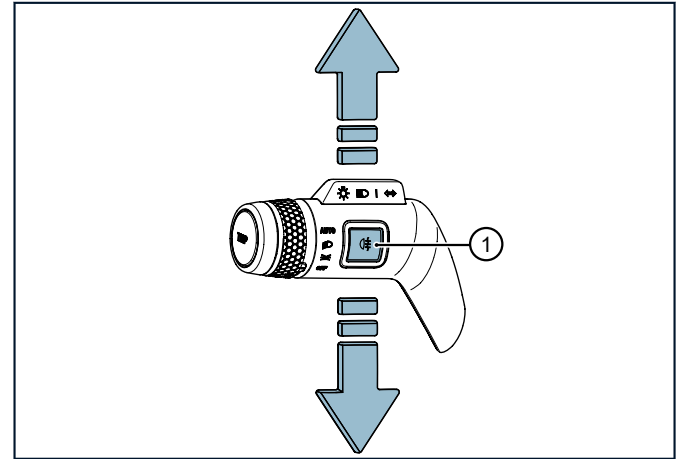

The rear fog light is for use in Reverse while in fog or other adverse weather conditions with low visibility.



**WARNING: Remember to switch off the rear fog light when it not needed. It can blind or distract other drivers.**

# OVERVIEW

---

## Reverse lights

When the ignition is set to ON and the Reverse gear is selected, the reverse lights will illuminate.

## LED auxiliary lights

The Grenadier as standard is fitted with LED Auxiliary Lights. These LED auxiliary high beam lights are in the front grill and are designed for off-road use only.

The LED Auxiliary Lights can only be activated with the high beam switched on and Off-Road or Wading mode is active.



**WARNING: The LED Auxiliary Lights are for use only off road when local laws and regulations permit. They are strictly for off-road purposes and could temporarily blind drivers in oncoming traffic.**

To Activate LED Auxiliary Lights:

1. Switch on the ignition and press the auxiliary light button  in the Overhead Control Panel.
2. The LED in the button will be illuminated to show the system is active.
3. When the headlights are turned on, the auxiliary lights will now also be illuminated.

To Deactivate LED Auxiliary Lights:

1. Press the auxiliary light button  in the Overhead Control Panel.
2. The LED in the button will be switch off.

## Puddle lamps

When a door is opened, the respective puddle lamp will automatically switch on from the underside of the door. If the door is closed, then the door puddle lamp will switch off. Puddle lamps will switch off after ten minutes if a door is left open and the ignition is off.

## INTERIOR LAMPS

Interior lamps include first row and second row reading lamps. Pressing the button nearest each reading lamp will toggle that lamp on and off. One may turn on all the lamps at once by pressing the

interior lamp switch  located on the Overhead Control Panel between the front seats. When the interior lamps feature is switched on, a small LED lamp will illuminate on the button.

The first row reading lamps are in the Overhead Control Panel, between the driver and front passenger.

The second-row lamps are in the center of the headliner. Each lamp has a switch with a diamond texture.

## OVERVIEW

---

Turn on door ajar lamps by pressing the Automatic Interior Lamps

switch  located on the Overhead Control Panel between the front seats. When the Automatic Interior Lamps feature is switched on, a small LED lamp will illuminate on the button. If the Automatic Interior Lamps switch is active, the first row and second row reading lamps switch on if a door is opened, even though the reading lamp or interior lamp switches are off. All lights are turned on/off simultaneously.



**WARNING: Interior lamp light can interfere with a driver's ability to see outside at night. Use these only when absolutely necessary while your Grenadier is being driven. Failure to heed this warning could lead to an accident and to serious injury and death.**

### Cargo Lamp (if equipped)

The cargo lamp is in the headliner at the rear of your Grenadier. It will illuminate when the Rear 30/70 Doors are opened. The cargo lamp will extinguish when the Rear 30/70 Doors are closed.

### Quartermaster Loadbay Lamp and 12v Power Outlet (if equipped)



**WARNING: It may not be legal to drive the vehicle with the Loadbay Lamp illuminated. The Loadbay Lamp should be switched off before driving the vehicle on public roads. Check local laws and regulations.**



**WARNING: When washing the Loadbay do not spray or expose the Loadbay Lamp to any cleaning solutions or chemicals. Failure to do so may result in damage to the Loadbay Lamp and/or the touch lens.**



**WARNING: Avoid hosing down or washing the Loadbay Lamp. Using a hose or pressure washer on the Loadbay Lamp can cause damage to the Lamp, Lamp lens and/or vehicle components.**

To activate the Quartermaster Loadbay Lamp, follow this procedure:

1. Switch the vehicle ignition ON
2. Switch the PWR button located in the Overhead Console to ON
3. Touch the white lens area of the Loadbay Lamp with your hand for 2 seconds.

## OVERVIEW

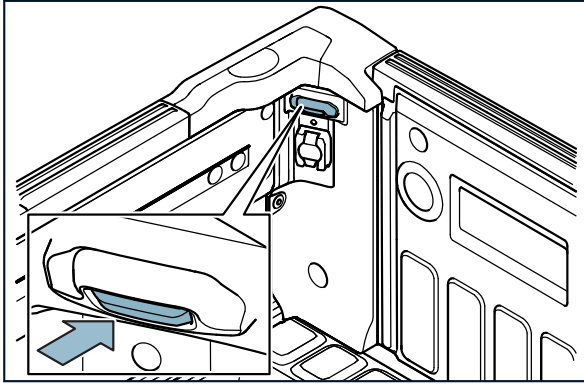

To deactivate the Quartermaster Loadbay Lamp, follow this procedure:

1. Touch the illuminated lens of the Loadbay Lamp with your hand for more than 1 second.
2. Switch OFF the PWR button located in the Overhead Console.

**i** *NOTE: If the Loadbay Lamp is not switched off manually, it may automatically switch OFF after 60 minutes.*

**i** *NOTE: The Loadbay Lamp's capacitive sensor, is designed to minimize the risk of the lamp turning ON from self capacitance during rain and water wash, although, it's not guaranteed to work in all user cases.*

**i** *NOTE: Wipe any excess water from the white lens surface and ensure hands are dry when switching ON or OFF the Loadbay Lamp.*

**i** *NOTE: If the supply battery voltage drops below 10v, elevates above 16v or the engine is cranked, then the Loadbay Lamp may switch OFF automatically.*

**i** *NOTE: Clear the Loadbay Lamp of dirt, debris and/or ice, before touching to switch ON or OFF the Loadbay Lamp.*

**i** *NOTE: Gloves must be removed before switching ON or OFF the Loadbay Lamp.*

**!** **WARNING: Avoid hosing down or washing the Loadbay 12v Power Outlet. Using a hose or pressure washer on the Loadbay 12v Power Outlet can cause damage to the outlet and/or vehicle components.**

**!** **WARNING: Ensure the Loadbay Power Outlet is free of dirt, debris, or ice before connecting any electrical devices. Failing to do so could damage the Loadbay Power Outlet or cause injury, potentially leading to serious harm or even death.**

## OVERVIEW

To activate the Quartermaster Loadbay 12v Power Outlet, follow this procedure:

1. Switch the vehicle ignition ON
2. Switch the PWR button located in the Overhead Console to ON
3. Plug in the electrical device.

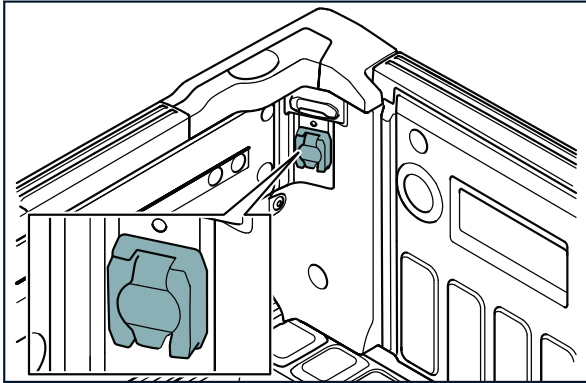

To deactivate the Quartermaster Loadbay 12v Power Outlet, follow this procedure:

1. Switch the PWR button located in the Overhead Console to OFF
2. Unplug the electrical device.



*NOTE: Wipe any excess water from the Loadbay 12v Power Outlet area and ensure hands are dry when switching plugging in any electrical device to the Loadbay 12v Power Outlet.*



*NOTE: Loadbay 12v Power Outlet rating: 120W / 12v.*



*NOTE: The Loadbay 12V Power Outlet fuse is a 15A mini fuse, located in the Cockpit Electrical Centre Fuse Box as fuse FC23.*

## OTHER CONTROLS

### Windshield Wipers

The right stalk controls your Grenadier wipers, wash, and wipe function. The front wipers are controlled by pushing the stalk up or

## OVERVIEW

down. Push the stalk back down, to the desired setting or off position, from a higher position.

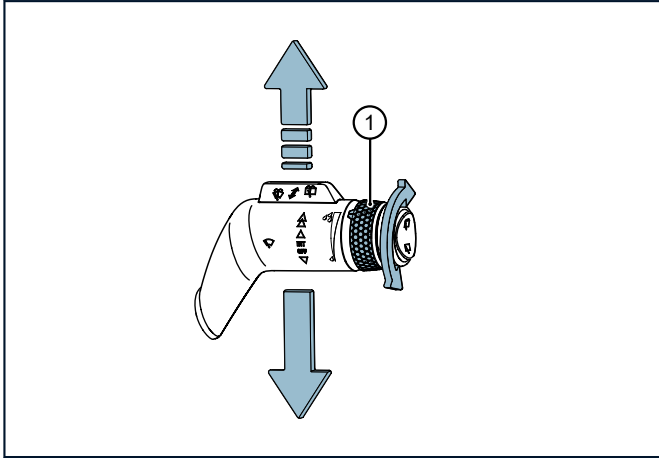

SPEED	DESCRIPTION
OFF	This is the bottom resting position for the selector. The front wipers are off.
QUICK WIPE	From the off position, when the stalk is temporarily pushed down, the wipers will perform a single sweep. The stalk will return to the off position as soon as it is released.

SPEED	DESCRIPTION
INTERMITTENT	Pushing the stalk one click up from the off position will turn on the wipers to sweep intermittently. The speed is controlled by the rotary selector (1). Twisting away from the driver increases the wiper speed; toward the driver will decrease the wiper speed.
LOW SPEED	Pushing the stalk two clicks up from the off position will put the wipers on a low speed, continuous sweep.
HIGH SPEED	Pushing the stalk three clicks up from the off position will put the wipers on a low speed, continuous sweep.

To protect the wiper arms when washing your Grenadier, either leave your Grenadier off or set the ignition to on and the wipers to off. This will keep the wiper arms locked into the park position and will help prevent damage.

### Windshield Washers

The wash and wipe are controlled by pushing the stalk away from, or pulling toward, the driver. Pushing the stalk away from the driver temporarily, will activate the rear washer and the wiper will perform a continuous sweep for a set amount of time. Pulling the stalk toward the driver temporarily will activate the front washers and the wipers

## OVERVIEW

will perform a low-speed sweep for a set amount of time. The stalk will return to the resting position as soon as it is released.

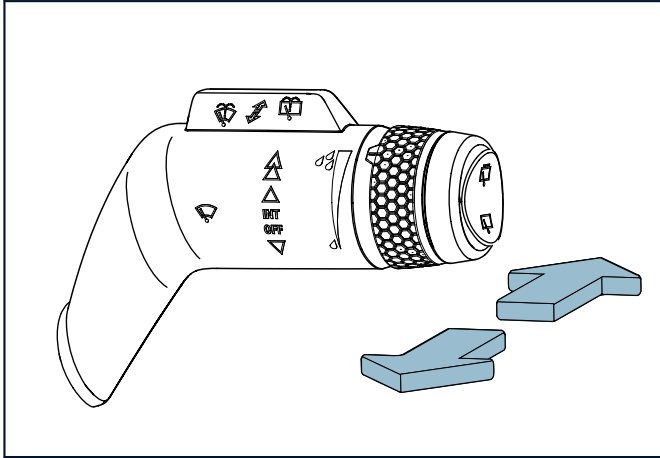

### Heated windscreen washer jets

The windshield washer warmers heat the front washer jets in cold weather to prevent the washer fluid from freezing. They are activated

with the heated rear window button. 

### Rear window wiper (if equipped)

The rear wiper is controlled with a three-position toggle button, on the end of the stalk.

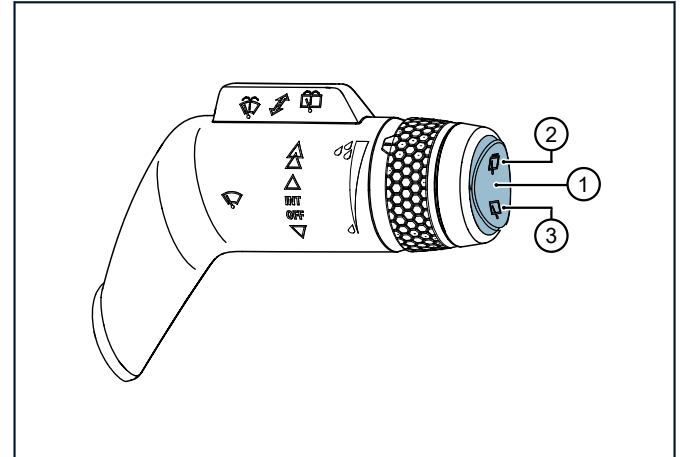

1. OFF - The top and bottom of the switch sit proud of the Stalk end. The rear wiper is off.
2. INTERMITTENT - Push the top of the button so that it sits flush with the end of the stalk. The rear wiper will sweep intermittently.



## OVERVIEW

---

3. CONTINUOUS - Push the bottom of the button so that it sits flush with the end of the stalk. The rear wiper will sweep continuously.

**qualified person. Damaging or removing fuses can disable functions. The batteries can shock a person or expose them to toxic chemicals. Failure to follow these instructions and precautions may result in serious injury and death.**

### DRIVING CONTROLS

The pedals, parking brake, transmission control, and differential locks are explained in the Driving On Road and Driving Off Road sections that follow.

### FUSE PANELS AND BATTERIES

A panel for the Cockpit Electrical Center Fuse Box is under the Ignition Switch to the right of the steering wheel.

The Interior Electrical Center Fuse Box is under the left rear passenger seat.

The vehicle battery is under the left rear passenger seat. The Auxiliary Battery (if equipped) is under the right rear passenger seat.

The Under-hood Electrical Center Fuse Box is under the hood on the drivers side.

These are discussed in detail in the Maintenance and Technical Information section.



**WARNING: Do not let anyone have access to the fuses or the batteries for any purpose other than repair by a**

# BEFORE DRIVING

---

INSPECTIONS .....	52
FUELING .....	53
A BRIEF WORD ABOUT TIRES .....	56

# BEFORE DRIVING

---

## INSPECTIONS

It's important to make sure your Grenadier is ready—and you're ready—before using it. You must make sure of both before any drive. You must check it periodically. And you must undertake a thorough inspection before carrying external cargo, heavy cargo, trailering, long trips, and off-road driving.

### Before any drive

- > Walk around your Grenadier making a visual inspection for damage, tire trouble, and obstacles. That's a particularly good idea if your Grenadier is parked where people might tamper with it or leave bikes and toys nearby.
- > Look under your Grenadier for signs of fluid leaks.
- > If you have cargo on the roof, in the Quartermaster bed, or on a hitchmounted carrier, make sure it's secured for normal driving and accidents. Make sure it does not exceed load and axle ratings.
- > If you parked with cargo attached to the side or back, remove it.
- > If there is cargo (or anything else that could be propelled and injure someone during a crash), secure or remove it.
- > Make sure you are not carrying more than the recommended load and that the weight of occupants and cargo does not put you over the Gross Vehicle Weight Recommendation in the Maintenance, Repairs, and Technical Information section.
- > Make sure all doors are securely closed.
- > Make sure that the windshield, windows, mirrors, and lamps are clear and unobstructed. If the windshield or windows are frosted, iced, or dirty, clear them before you start driving, now while you are underway.
- > Make sure that the rear and side mirrors are adjusted for the driver.
- > Make sure that the steering wheel is adjusted to the driver's liking.
- > Make sure that the driver footwell is clear of anything that is obstructing or that could move to obstruct a pedal.
- > Put down your phone and resolve not to check it or use any function other than hands-free while driving.
- > Resolve to pay full attention to driving.
- > Make sure all occupants are properly seated and seat belted.
- > After starting the engine, check the Telltale Cluster and the Center Display and Touchscreen for any signals indicating trouble and resolve them before driving.

# BEFORE DRIVING

---

## Periodically and before long trips, trailering, and off-road driving

In addition to everything mentioned above:

- > Test the tire pressures (including the spare's) and adjust as required to reach recommended cold pressure. This is particularly important if you are driving with a heavy load of cargo, occupants, or both. Do not rely on the Tire Pressure Monitoring System (see Driving on Road) to tell you when to adjust tire pressure.
- > Inspect wheels, wheel lug nuts, and tires for any irregularities.
- > Test all lamps and signals on your Grenadier and the trailer (turn, hazard).
- > Test audible signals (horn, toot).
- > Test washers, and wipers.
- > Check fluid levels and get them topped off.
- > Make sure that all of the recommended trailer attachments are present and secured.
- > Make sure that the load on the trailer is secured to the trailer.
- > Test the service brake and parking brake with the trailer attached.

## Inspection-related warnings



**WARNING: Failure to follow these instructions and precautions may result in an accident and in serious injury and death.**

## FUELING

### Fuel Type

It is essential to use the correct fuel in your Grenadier. If you do not use the correct fuel, the fuel system and the engine might be damaged.

You must use only uncontaminated (e.g., water and particulate free) unleaded gasoline with no more than 15% ethanol content. Do not use:

- > Fuel containing more than 15% ethanol (e.g., E85).
- > Diesel fuel.
- > Fuels containing the octane booster additive, methylcyclopentadienyl manganese tricarbonyl (MMT).
- > Leaded fuel. Using leaded fuel is prohibited by law.

## BEFORE DRIVING

We recommend at least 91 Octane (Pump Octane Number). Your Grenadier will tolerate lower Octane fuels for short and infrequent use.

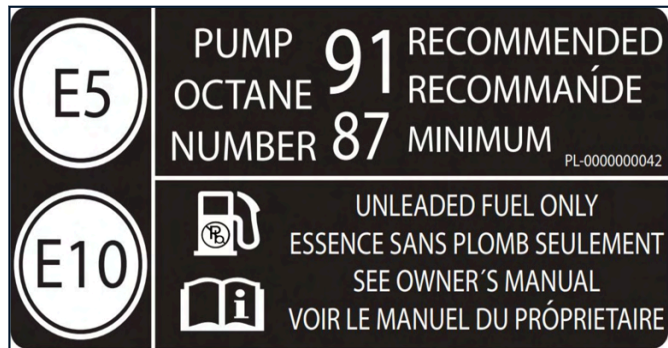

range if you are driving aggressively, pulling a trailer, carrying a heavy load, driving off-road, or driving over hills.



### Fuel Tank Capacity

Your Grenadier's fuel tank can hold 23.7 U.S. liquid gallons (90 L) of gasoline.

### Fuel Level and Range

Fuel level and approximate remaining range are shown on the Center Display and Touchscreen. Note that the remaining range is a prediction based on driving style. It can be lower than the actual

# BEFORE DRIVING



Fuel level warnings will be displayed in three stages as fuel is depleted:

1. "Remaining Range" will turn orange when you have between 40 and 70 miles of estimated range remaining.
2. "Refuel soon" will also appear when you have between 40 miles and 70 miles of estimated range remaining.
3. "Refuel now" will appear when you have less than 40 miles of estimated range remaining and the reserve fuel is being used.



**NOTE:** Avoid triggering the Refuel Now signal. Do not run the fuel out completely. Running the fuel too low increases the risk of clogging the fuel tank filter and otherwise disabling the engine.

## Fueling at a gas pump

- > Switch off the ignition.
- > Leave your cell phone in your Grenadier. If there is a risk that you are carrying static electricity, ground yourself by touching some metal object that is connected to the ground before you open the fuel door.
- > Don't smoke or let anyone else smoke or have open flame or sparks or devices that can cause such nearby.
- > The fuel door is located at the rear passenger side of your Grenadier. Your Grenadier must be unlocked to open the fuel door. Push the rear edge of the fuel door inward and release. The fuel door will pop open.
- > Turn the fuel cap counterclockwise slowly to open.
- > Once the cap is removed, place it in the receptacle provided on the inside of the fuel door.
- > Insert the pump nozzle into the fuel filler inlet and dispense fuel. Fuel pumps have an automatic cut off when the tank is full. Do not continue fueling past a full tank because this will lead to spillage.
- > Remove and replace the filling nozzle.

Replace the fuel cap and push the fuel door closed.

# BEFORE DRIVING

---

## Fueling elsewhere

- > Park on relatively level ground. Attempting to fuel on a slope risks spillage, environmental harm, and fire.
- > Follow all the same instructions mentioned above for fueling at a gas pump.

## Fuel Warnings



**WARNING: Failure to follow these instructions and precautions could result in a fire, in vehicle disablement, and in serious injury and death.**

## Fuel economy

Factors that influence your Grenadier's fuel economy include:

- > Driving habits, such as aggressive acceleration, speeds, and braking.
- > Weather, such as extreme temperatures and poor road conditions.
- > Frequent short trips instead of consolidated journeys.
- > Hilly, uneven, and low traction terrains.
- > Towing.
- > Heavy cargo.



Heavy use of any device that draws electricity and makes the engine work harder to maintain power and reduce efficiency.



Poor maintenance such as low tire pressure, poor wheel alignment, dirty oil, and dirty air filters.



Options and Accessories fitted to the exterior of the vehicle that may cause increased drag.

## A BRIEF WORD ABOUT TIRES

Your tires are among the most important components of your Grenadier. They are what allow you to accelerate, brake, corner, and hold the road or path. Underinflated tires, overinflated tires, damaged tires, worn tires, misaligned tires, and the wrong tires carry risks of accidents, loss of control, disablement, serious injury and death.

You must frequently check your tires for any irregular or unusual condition and promptly remedy any condition that could affect performance. If in doubt, remedy; or contact your INEOS dealer.



**WARNING: Failure to follow these instructions and precautions may result in serious injury and death.**

# DOORS AND WINDOWS

---

INTRODUCTION .....	58
SIDE DOORS .....	58
30/70 REAR DOORS .....	59
DOOR LATCHES .....	60
DOOR FEATURES AND FUNCTIONS ON THE CENTER DISPLAY AND TOUCHSCREEN .....	61
DOOR WARNINGS .....	61
WINDOWS .....	62



# DOORS AND WINDOWS

---

## INTRODUCTION

Your Grenadier has six doors: four side doors and two rear doors. Each door has a window.

When opening and closing doors, be particularly careful when your Grenadier is on a slope. A slope can apply force to a door. That can cause a door to swing open or closed unexpectedly.

Never open a door while your Grenadier is in motion.

## SIDE DOORS

### Operating the side doors from outside

- > Press and release the Unlock Button on your key once to unlock only the driver's door.
- > Press the Unlock Button twice to unlock all doors including the rear. This can be customized in the SETTINGS tab.
- > Or insert the Key Blade into the driver's door lock to unlock all doors.
- > To open the door, grasp the door handle, push the button, and pull outward.
- > Once inside and the way is clear of objects (e.g., seat belts, fingers, feet, clothing), close the door firmly; don't slam it.
- > Lock the door by pressing the Lock Button on the key once or by having the driver use the power locks.

### Operating the side doors from inside

- > If the door is locked, it can be unlocked with:
  - The power door lock switch; or
  - The interior door handle by pulling it toward you.
- > Check outside for obstructions and approaching vehicles, bicyclists, and people.
- > Pull the handle toward you to unlatch (and unlock) the door.
- > Push the door open.
- > Once outside and the way is clear of objects (e.g., seat belts, fingers, other occupants), close the door firmly; don't slam it.
- > If you wish to lock all doors, use the lock button on your Grenadier key.

### Child door locks

Your Grenadier is installed with child locks inside the rear doors only. They are designed to stop children opening the doors from inside your Grenadier. In the image below, position (A), indicates the child

# DOORS AND WINDOWS

locks are activated. Position (B) indicates that the child locks are not activated.

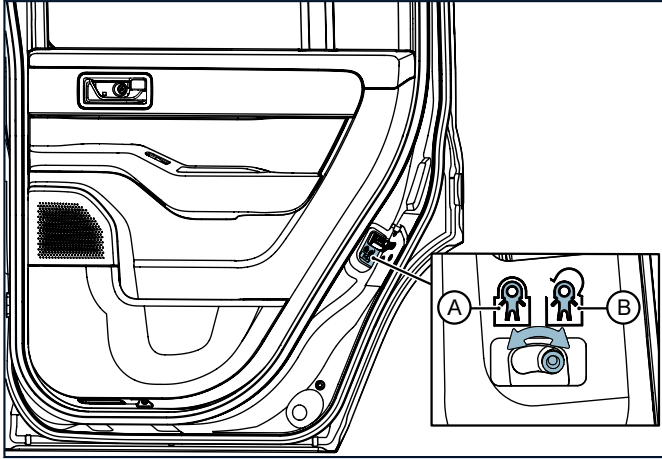

## 30/70 REAR DOORS

### Operating the rear doors from the outside

- > Open the 30-side first.
- > Unlock the doors using the key unlock button or the door unlock button on the inside of the driver door.
- > Grasp the handle on the 30 side door, press the button in the handle, and pull the handle and door toward you.
- > Swing the door open fully. Note that there is a detent to hold the door open.
- > Then address the 70-side.
- > Check for clearance on the passenger side of your Grenadier. When the 70-side door is fully open, the spare tire will protrude beyond the passenger side.
- > Grasp the vertical door release handle just inside the 70-side door.
- > Pull the 70-side door open, being mindful of the added weight from the spare tire.

A gas strut is mounted horizontally at the bottom of the 70 side door. It assists with moving the weight of the door and spare tire. Note there is no detent and the gas strut will not hold the 70-side door open. Never hang any objects from the gas strut; it will not function properly if bent.



**NOTE:** Note that there is no detent to keep the 70 side door open. It can be closed by wind. It can be closed by pushing. It can be closed by gravity if the Grenadier's

# DOORS AND WINDOWS

*front is lower than the rear on a slope. Keep body parts and objects clear of the 30/70 doors. To close the rear doors, stand to the side to avoid the path of the doors. Check for obstructions. Avoid closing the door on objects and be sure that no cargo is in the path of the door. Close the 70 side door first. Then close the 30 side door. Make sure that each is latched. To close the rear doors, stand to the side to avoid the path of the doors. Check for obstructions. Avoid closing the door on objects and be sure that no cargo is in the path of the door. Close the 70-side first. Then close the 30-side. Make sure that each is latched.*

## Operating the rear doors from the inside

The rear 30/70 doors have door release handles on the inside in case someone is in the cargo area when one or both doors was closed. Never allow an occupant to sit in the cargo area when your Grenadier is moving.

## DOOR LATCHES

Your Grenadier's side doors have two latching positions: primary and secondary. The door is in the primary latched position if it is snugly and firmly closed. The door is in the secondary latched position if it will not easily swing open but it is not snugly and firmly closed. The primary latch is stronger and securely latches the door. The secondary latch is a backup position required by the National Highway Traffic Safety Administration.

Your Grenadier will send a sound signal and a visual signal on the Center Display and Touchscreen if a door is not in the primary latch position and the vehicle is put into drive or reverse. The Center Display and Touchscreen will show a graphic indicating which doors are open. Do not drive your Grenadier if any door is not closed and fully latched.



# DOORS AND WINDOWS

## DOOR FEATURES AND FUNCTIONS ON THE CENTER DISPLAY AND TOUCHSCREEN

Many features related to your Grenadier's doors can be customized through the Central Display. Select your Grenadier FUNCTIONS menu of the SETTINGS tab to access these settings:

- > Central Locking System: The Central Locking System provides the convenience of locking or unlocking all doors of your Grenadier with a single action, using either the key or, the interior locking button.
- > Drive Away Locking: For enhanced security, the Drive Away Locking feature automatically locks all doors when your Grenadier reaches a predetermined speed.
- > Leaving Home Light Timeout: When you unlock your Grenadier, the Leaving Home Light Timeout feature illuminates the headlights for a predetermined duration to illuminate surroundings.
- > Remote Lock Feedback: This feature provides a sound and a visual signal when locking your Grenadier using the remote.
- > Follow Me Home: Activate the Follow Me Home feature to keep the headlights on for a set period after turning off the ignition. This illuminates the area covered by the headlights.

## DOOR WARNINGS



**WARNING:** Make sure all doors are fully latched and locked before driving.



**WARNING:** The Central Locking System is not a child lock.



**WARNING:** Unless the Child Lock is activated, the rear side doors can be unlocked and opened by pulling on the handle.



**WARNING:** The front side doors can always be unlocked by pulling on the interior handle.



**WARNING:** Do not stand on or hang objects from the door latch strikers, including the rear 30/70 door. The latch striker is not a step. You could be injured if you slip or fall.



**WARNING:** Do not allow anyone to use the roof Access Ladder (if equipped) (e.g., climbing on it, standing on it, hanging on it, hanging anything on it) while either of the rear doors is unlatched.



**WARNING:** Doors may be impossible to open when obstructed by water. If you need to exit a vehicle in an emergency and a door won't open, try another door or exit through a window opening.

# DOORS AND WINDOWS



**WARNING:** Failure to follow these instructions and precautions and those in the Doors subsection could result in injury, serious injury and death.

## WINDOWS

### Introduction

In addition to the windshield, there are windows in each door. Your Grenadier may have been ordered with the option of additional Safari windows in the roof over each front seat.

### Windshield

A clear, high-quality windshield is essential to safe driving.

Your ADAS functions (see Driving On Road) require that the camera have a clear view out of the windshield.

If your windshield must be replaced, replace it with a genuine INEOS replacement part. Aftermarket windshields may not be of sufficient quality. Make sure that the ADAS camera is recalibrated.

### Side Windows

Each side door has a movable side window. Each is moved by an electric motor. The motor for each is controlled by a toggle switch on the inside of each door. The driver door has switches for each door's window.

The ignition must be in ACC (Accessory) or ON for the windows to operate. Once the ignition is turned to OFF, the window motors can be activated for 60 seconds or until a door is opened, whichever happens first.

All windows have a one-touch down feature. To use, press the switch all the way down (past the click), to cancel pull up the switch again, briefly.



### WARNING:

- > There is no means of locking windows. Any occupant who can reach a window switch can operate a window.
- > The child door locks do not deactivate the rear window switches.
- > There is no anti-pinch or automatic reverse feature on any of the windows, including the rear windows. It will keep moving and applying pressure even if an object or body part (e.g., finger, hand, head, neck) is in the way. Be sure that the window opening is clear before rolling up any window. Never allow children to remain in your Grenadier unattended with the ignition in ACC (Accessory) or ON. Always supervise children's use of the rear windows.
- > Keep objects and body parts inside your Grenadier, not sticking outside a side window, while your Grenadier is being driven.

# DOORS AND WINDOWS

---

- > Do not use window openings to get into or out of your Grenadier except in an emergency when there is no other way.
- > Failure to follow these instructions and precautions may result in injury, serious injury and death.

## Rear Windows

The windows in the 30/70 rear doors and the side windows in the cargo area are fixed. They do not move. The same applies for the rear windows in the Quartermaster, they are also fixed in place and do not move.

Keep them clear and unobstructed so that the driver has a clear field of vision.

## Safari Windows (if equipped)

Safari windows may be in the roof of your Grenadier, over each of the front seats. Each has a latch on the rear side, toward the rear of your Grenadier. Each has hinges on the front side.

To open a Safari window, push the bottom of the latch forward. The window is then unlocked. Push the window upward until the latch snaps into position to hold the window open.

To close a Safari window, push the center (hinge/pivot point) of the latch forward. Allow the window to drop into the closed position. Then pull the bottom of the latch rearward to lock it.

To remove a Safari window:

- > Push the bottom of the latch forward.
- > Push the window upward.
- > Lift the bottom of the latch lock upwards and then move the latch forward to disconnect it from the rear mounting point.
- > Push the window to near vertical.
- > Pull the window upward with both hands until the hinges are free of their mounts in the roof.
- > Turn the window to an angle that will allow it to pass through the opening and bring it into your Grenadier.
- > Stow the window.

To reposition a Safari window:

- > Guide the window upward through the opening with both hands and position it so that the latch will be inside and to the rear of your Grenadier when the window is closed.
- > Guide the hinges into the front mounts.
- > Gently lower the window until it is closed.
- > Reposition the bottom of the latch with one hand and close the latch with the other.

Have a firm grip when removing and repositioning a Safari window. If it slips and falls, it could injure.

## DOORS AND WINDOWS

### Station Wagon:

To stow a Safari window, put it in the dedicated storage bag and secure it in on the floor of the cargo area using the tie-down rings or Utility Rails (if equipped). (See Cargo Loading and Securing.)

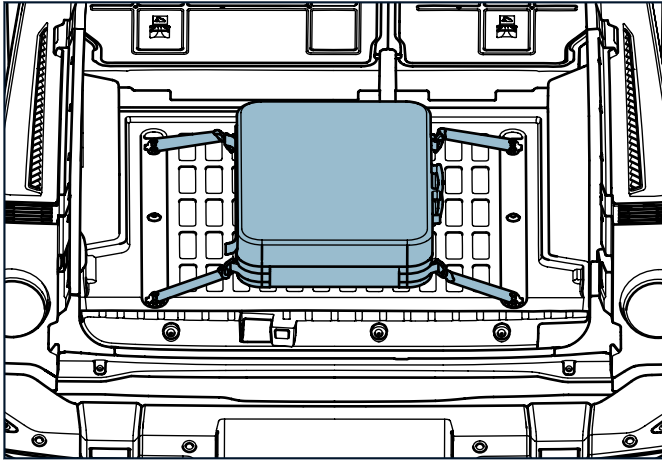

### Quartermaster:

In the Quartermaster, position the bag on either of the two outboard seats of the rear bench in a portrait orientation, ensuring the

handles face inward. Secure the bag by feeding the respective seat belt through both handles and locking it into place.

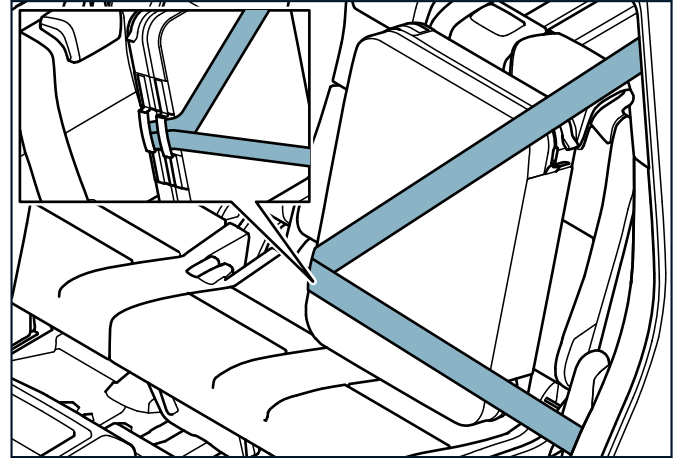

Do not use the Safari window openings to enter or exit your Grenadier except in an emergency when there is no other way.



**WARNING:** Failure to follow these instructions and precautions may result in serious injury and death.

# SEATS, SEAT BELTS, CHILDREN IN CAR SEATS & BOOSTER SEATS, & AIR BAGS

---

INTRODUCTION .....	66
SITTING PROPERLY .....	66
SEAT BELTS .....	74
CHILDREN IN CAR SEATS AND BOOSTER SEATS .....	79
AIR BAGS .....	89
ADDITIONAL AIR BAG WARNINGS .....	91



# SEATS, SEAT BELTS, CHILDREN IN CAR SEATS & BOOSTER SEATS, & AIR BAGS

## INTRODUCTION

Where you sit, how you sit, and how you are restrained can affect the risk of injury and death, particularly in crashes. This section provides information about how to reduce those risks.



*NOTE: Throughout this manual, the term “adult” refers to any person who is large enough to sit comfortably, properly, and safely in one of the Grenadier’s seats and seat belts with both feet on the floor. People over age 12 are usually able to do so. See <https://www.nhtsa.gov/sites/nhtsa.gov/files/nhtsacarseatrecommendations.pdf>. The use of the term “adult” refers to occupant size, not legal status or calendar age.*

## SITTING PROPERLY

Sitting properly in a vehicle is crucial for the effective operation of all of your Grenadier’s safety features.

All occupants must:

- > Be the sole occupant of one of the five designated seating positions (driver, front passenger, left rear, center rear, or right rear).

All adult occupants in a front seat must:

- > Adjust and lock the seat so that it is no closer to the air bag than necessary.
- > Adjust and lock the front seat back so that it is relatively upright and not greatly reclined.

The driver must also:

- > Position and lock the driver’s seat horizontally (forward and rearward) and vertically (up and down) so that the pedals, the steering wheel, and the controls are within easy reach and the chest is at least 10 inches (25 cm) from the steering wheel.
- > Hold the steering wheel at 9 and 3 o’clock and keep the arms slightly bent. This promotes steering wheel operation and reduces the risk of injury from air bag deployment.

All Occupants of all seats must:

- > Adjust the head restraint so that the center of the head restraint is as close as possible to the center of the back of the head.
- > Sit centered, upright, and with the buttocks against the seat back, not slouched.
- > Keep both feet on the floor.
- > Avoid leaning to one side or another.

All children (occupants smaller than an adult-sized person) must be in a rear seat position whenever possible. Never, under any

# SEATS, SEAT BELTS, CHILDREN IN CAR SEATS & BOOSTER SEATS, & AIR BAGS

circumstances, place a child in a rear-facing infant seat in the front passenger seat.

All children must be seated in a Rear-Facing Car Seat, a Forward-Facing Car Seat, or a Booster Seat if:

- > Required by state law ; or
- > If recommended by NHTSA ; or
- > If unable to sit properly and be properly belted (see the Putting on a seat belt subsection below) in a Grenadier seat and seat belt.



**WARNING: Failure to follow these instructions and precautions may result in serious injury and death.**

## Adjusting a front seat

To adjust the horizontal position of a front seat:

- > Make sure that your Grenadier is stopped and in P (Park).
- > Unlock the forward/rearward seat lock by pulling up on the bar just under the front of the seat cushion.



- > Slide the seat forward or rearward to a safe position.
- > Release the handle to lock the seat into position.
- > Make sure that the seat is locked in position by trying to move it forward and rearward before your Grenadier is taken out of P (Park) and moved.

To adjust the vertical position of a front seat:

- > Make sure that your Grenadier is stopped and in P (Park).
- > Lift the handle on the outboard side of the seat pan to pump the seat upward.

## SEATS, SEAT BELTS, CHILDREN IN CAR SEATS & BOOSTER SEATS, & AIR BAGS

- > Push that handle down to pump it downward.

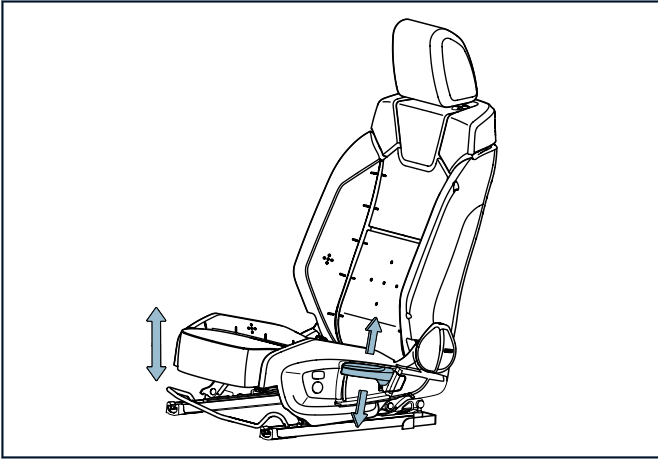

To adjust a front seat back:

- > Make sure that your Grenadier is stopped and in P (Park).
- > Turn the control lever on the lower part of the outboard side of the seat back toward the back of your Grenadier and lean against the seat back to recline the seat.
- > Turn the control lever toward the back of your Grenadier and release pressure on the seat back to allow the seat back to spring forward to straighten the seat back upright.

- > Once the seat back is in a comfortable position, make sure that it is locked into position before your Grenadier is taken out of P (Park) and driven.

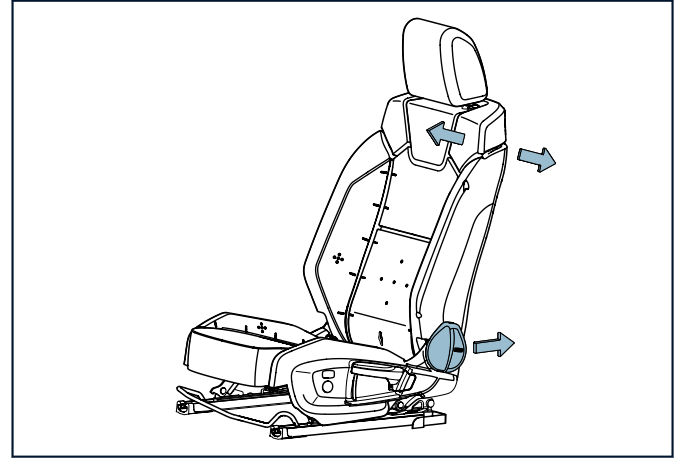

### Folding a rear seat

The rear seats are not adjustable horizontally. The rear seat backs are not adjustable. They are either up or folded forward. If they are up, make sure that they are locked into position before your Grenadier is taken out of P (Park) and driven.

The rear bench seat is a 60/40 split and can be folded forward in two sections.

## SEATS, SEAT BELTS, CHILDREN IN CAR SEATS & BOOSTER SEATS, & AIR BAGS

Remove the head restraint before folding the seat. Fold the bottom seat cushion (1) forward, then pull the loop (2) above the single outer seat.

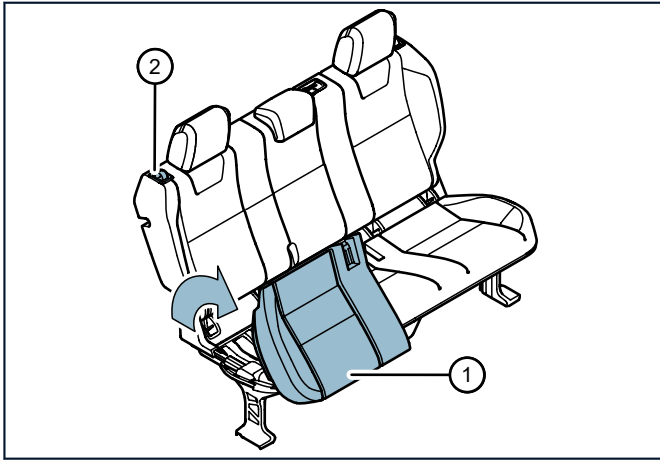

Fold the seat back (3) forward.

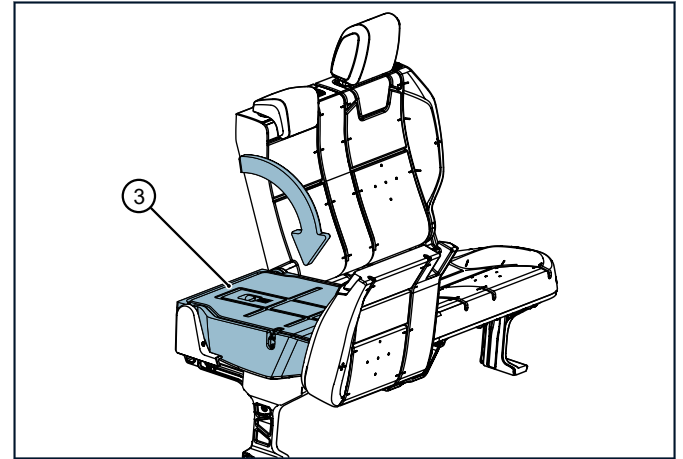

It is possible to fold the seat back forward to lie flat on top of the lower cushion without removing the head restraints. However, INEOS recommends removing the head restraint using the method shown above instead because it reduces the risk of contact between the head restraint and a front seat back or front seat occupant, and it protects the head restraint once that is stored away. Make sure to secure any head restraint that has been removed. Do not allow it to remain loose in your Grenadier.

## SEATS, SEAT BELTS, CHILDREN IN CAR SEATS & BOOSTER SEATS, & AIR BAGS

To return the folded seats to the upright position:

- Lift the seat back.
- Make sure that the outboard shoulder belts are not trapped behind or adjacent to the seat back by pulling it forward while returning the seat back to its upright and locked position.
- Lock the seat back into place.
- Make sure that the seat belt buckles are visible and accessible once the seat bottom is put into place.
- Replace the head restraint.
- Make sure that the rear seat is locked into position before your Grenadier is taken out of P (Park) and driven.

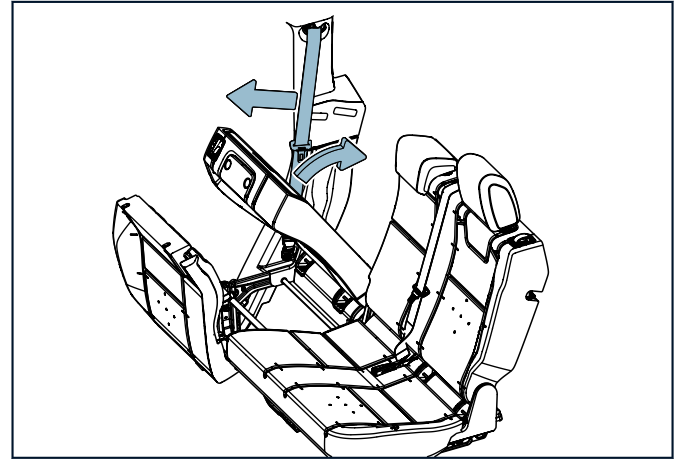

If the red indicator on the loop strap is visible, the seat back has not been locked. Occupants might be injured if your Grenadier is operated with unlocked, upright seat backs.



**WARNING:** Failure to follow these instructions and precautions may result in serious injury and death.



**WARNING:** The vehicle battery and electrical components are stored under the rear bench seat. Do not store any objects under the seat bottom cushion. Doing so could lead to exposure to toxins or a fire, and could result in serious injury and death.

# SEATS, SEAT BELTS, CHILDREN IN CAR SEATS & BOOSTER SEATS, & AIR BAGS

## Removing and adjusting head restraint

All your Grenadier's seats are equipped with a head restraint consisting of:

- > **Restraint pad:** This is the cushioned part that the back of the occupant's head contacts. It's designed to comfortably support the head while being firm enough to provide protection in a crash.
- > **Posts:** These are the vertical metal rods that insert into the top of the seatback. They allow for the adjustment of the height of the head restraint to properly align with the occupant's head.
- > **Guide channels:** These are the parts on the seatback where the posts slide in and out, allowing for height adjustment.
- > **Control button:** a button that unlocks the ends of the posts, allowing a head restraint to be removed from the seat back.

All head restraints are removable.

- > To remove a head restraint, push the control button inward at the base and pull the head restraint until fully detached
- > To install a head restraint, make sure the head restraint is facing forward, and then push the control button inward and push the head restraint into the location holes in the top of the seat.

- > Never remove or install a head restraint while your Grenadier is in motion.

Front:

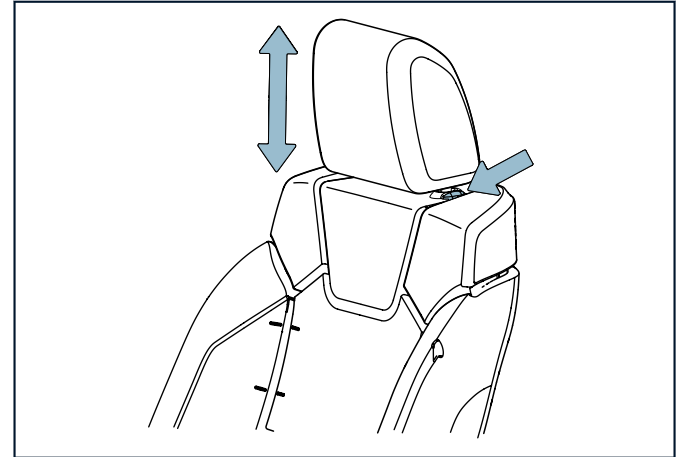

## SEATS, SEAT BELTS, CHILDREN IN CAR SEATS & BOOSTER SEATS, & AIR BAGS

Rear:

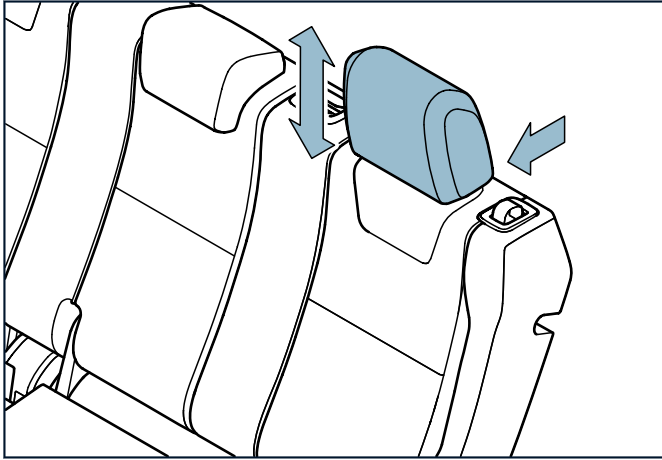

To adjust a head restraint, pull the head restraint upward until the desired height is achieved. To lower a head restraint, push the control button at the base of the head restraint, lower the restraint to the desired position, then release the control button to lock it

there. Never adjust a head restraint while your Grenadier is in motion.



### Seat heaters (if equipped)

Your Grenadier may have been ordered with optional heaters for the front seats. There is a control for each seat on the Center Console.

Be careful of the setting, particularly with those with diminished sensation (e.g., elderly people, people with decreased sensation in the buttocks and legs) and those with diminished capacity to communicate (e.g., impaired occupants, people with dementia,

## SEATS, SEAT BELTS, CHILDREN IN CAR SEATS & BOOSTER SEATS, & AIR BAGS

children). As with any heater, the heat can accumulate to the point that one may get mild to even severe burns. People with diminished sensation may not realize it. People with diminished capacity to communicate may be unable to let you know.

Do not leave the heaters on when you leave such people unattended.

Heaters also pull electricity. They can drain the battery when left on while the ignition is in the ACC (Accessory) position.



**WARNING: Failure to follow these instructions and precautions may result in serious injury and death.**

### Seat warnings



#### WARNING:

- > Never ride or allow anyone to ride in your Grenadier without being in one of the five designated seating positions.
- > Riding with the seat back other than relatively upright increases the risk that an occupant may slide under the lap belt. That can lead to serious injury and death.
- > Riding without the buttocks against the seat back (slouching) can increase the risk that the occupant may slide under the lap belt. That can lead to serious injury and death.

- > Riding with feet raised off the floor increases the risk that an occupant may slide under the lap belt. That can lead to serious injury and death.
- > Riding with the front passenger's feet on the dash increases the risk of contact with the deploying air bag. That can lead to amputation of the feet, serious injury and death.
- > Sitting too close to a frontal air bag can increase the risk of contact with the air bag as it deploys, resulting in facial and eye injuries, neck injuries, other serious injuries, and death.
- > Sitting too close to a window and in the deployment zone of a side curtain air bag can increase the risk of injury from a deploying side air bag, including serious injury and death.
- > Make sure that the seats are locked into position on their forward/rearward tracks before driving. Never adjust a seat while your Grenadier is in motion. Doing so can lead to an accident and to serious injury and death.
- > Never allow any adult to ride in a seat with the head restraint removed or improperly installed or adjusted. Doing so can lead to an accident and to serious injury and death.



# SEATS, SEAT BELTS, CHILDREN IN CAR SEATS & BOOSTER SEATS, & AIR BAGS

---

- > All occupants, including the driver, should not operate a vehicle or sit in a vehicle's seat until the head restraints are placed in their proper positions in order to minimize the risk of neck injury in the event of a crash.

## SEAT BELTS

### Introduction

Your Grenadier is equipped with a seat belt at each seating position. The seat belt is the primary restraint system for each adult. Each person in your Grenadier must be the sole occupant of one of the five seating positions.

All seating positions in your Grenadier have lap and shoulder seatbelts. Airbags are designed to supplement, and not replace, seatbelts. It is essential that all occupants are correctly seated and using their seat belts properly, for their own safety and the safety of others in the vehicle. Even with airbags, serious injuries and possible death can occur if seat belts are not worn correctly.

The seat belt works when it is buckled. A retractor at the end of the shoulder belt applies load to the belt to snug it over the belted occupant's chest. During ordinary driving, the retractor will allow webbing to be pulled off the retractor so that an occupant wearing

the Grenadier's seat belt can move within the seat. During a crash, the retractor will lock when it senses either:

- > That forces (Gs) exceeding a certain threshold are being applied to your Grenadier's body;
- > That the webbing is being pulled out at a speed above a certain rate; or
- > Both.

There is also a pre-lock "Automatic Locking Retractor" function for use with car seats. This is triggered when the webbing is pulled all the way out and is then allowed to retract. When the webbing is pulled all the way out, it triggers a switch which activates the pre-lock ALR function. The pre-lock ALR then sets a lock as the webbing is retracted more and more. The lock will make a clicking sound as you allow the webbing to retract. This allows the seat belt to secure a car seat without having the car seat move about during normal driving. But this also can keep an adult from moving in the seat belt webbing. To turn off the pre-lock ALR function, simply let the seat belt webbing retract all the way. Then the pre-lock ALR function will turn off and the webbing can be pulled out normally.

Note that the retractor may lock outside of a crash when your Grenadier is on a steep slope or the webbing is pulled on rapidly. That is normal operation; the retractor senses Gs and webbing pull rate, not vehicle body damage.

# SEATS, SEAT BELTS, CHILDREN IN CAR SEATS & BOOSTER SEATS, & AIR BAGS

## Putting on a seat belt

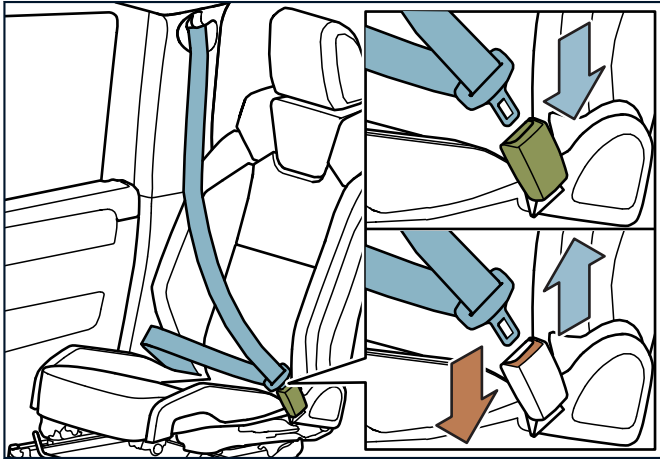

To fasten a seat belt in any of the four outboard seating positions (next to a front or rear door) around an adult occupant:

- > Adjust the seat position if desired and if you are in the front seat.
- > Reach up and take hold of the seat belt tongue that is hanging on the pillar outboard of your seat.

- > Pull the tongue and seat belt smoothly across your chest and down to the buckle on the inboard side of your seating position.
- > Insert the seat belt tongue into the buckle until it clicks. Pull on it to ensure it is latched.

To fasten the center rear seat around an adult occupant:

- > Reach up and take hold of the seat belt tongue that is resting above and to the left (driver) side of the center seating position.
- > Pull the tongue and seat belt smoothly across your chest and down to the buckle on the right (passenger) side of your seating position.
- > Insert the seat belt tongue into the buckle until it clicks. Pull on it to ensure it is latched.

In all five seating positions:

- > Make sure that the webbing is not twisted and that it lies flat across the body.
- > Make sure that the lap portion of the webbing is low and tight across the hips. Do not let it pass over the abdomen.
- > Make sure that the shoulder webbing is in front of the chest, never behind.
- > Pregnant occupants must wear the lap belt as low as possible below the abdomen. Never let the lap belt pass over or above the baby.

## SEATS, SEAT BELTS, CHILDREN IN CAR SEATS & BOOSTER SEATS, & AIR BAGS

- > Seat belts are designed to restrain occupants by bearing upon the bony structures of the body. If the seat shoulder belt is not over the collar bone and chest, it can load soft tissues or vulnerable parts like the neck. If the lap belt is not low and tight across the hips, it could load the soft tissue of the abdomen.
- > If the seat belt cannot be comfortably worn over the collar bone, chest, and hips of a smaller occupant, that occupant must be moved to a booster seat or other seat.
- > If a seat belt will not latch, take your Grenadier to an INEOS dealer immediately. Do not allow anyone to occupy the seat with a seat belt that will not latch.

Seat belts are for people, infant seats and car seats. They are not for cargo or pets. Do not attempt to secure anything other than a person, an infant seat, or a car seat with a Grenadier seat belt.

### Releasing a seat belt

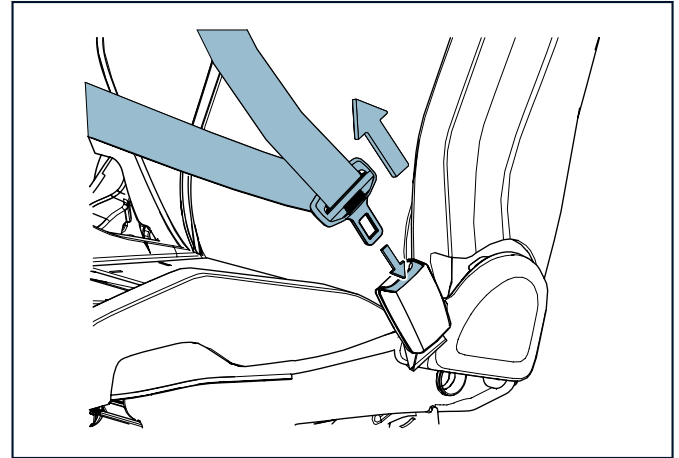

To release your seat belt:

- > Hold the seat belt and push the red buckle release button.
- > Guide the tongue and seat belt webbing as it retracts to the stowed position.

# SEATS, SEAT BELTS, CHILDREN IN CAR SEATS & BOOSTER SEATS, & AIR BAGS

---

## Seat belt reminder

The seat belt reminder warning symbol  is displayed in the instrument cluster, accompanied by an audible alert, to indicate that a front seat occupant either hasn't fastened or has unfastened their seat belt. This reminder is activated when a switch detects a weight (mass) in the seat that exceeds a certain threshold and vehicle's speed exceeds 15 mph (25 km/h) . The audible alert will sound up to about 93 seconds.

Never buckle the seat belt behind an occupant or insert any object into the buckle for the purpose of stopping the reminder light or sounds. The seat belt reminder is intended to encourage front seat occupants to wear their seat belts. Never disconnect or otherwise defeat the seat belt reminder.

The rear seats do not have a seat belt reminder mat. The detection of occupants on the rear seat is done by monitoring the change of state of the seat belt buckle. If a buckled seat is unbuckled during

driving the seat belt reminder warning symbol  is displayed in the instrument cluster.

The seat belt reminder function is designed to recognize an adult-sized occupant. It may not be activated by a car seat or child.

The driver must always ensure that all occupants are belted before driving, and that they all remain belted while driving. Unrestrained and improperly restrained occupants are a hazard to themselves and to others.

## Wearing a seat belt

Keep the webbing properly positioned while wearing the seat belt. Do not allow it to be relocated by changing your seating position. Check your occupants periodically to make sure that they have not gotten out of position.

Do not use devices to reduce tension on either belt or to put slack in the system (e.g., "window shade" clamps).

Do not use seat belt extenders.

Do not use pads or cushions on the shoulder belt.

Do not add anything to the seat belt.

## During a crash

During a crash, the occupant's body loads the seat belt by pressing against it after the retractor locks the webbing. This can involve thousands of pounds of force in about a tenth of a second. The seat belt cannot help the occupant unless it is being worn. It cannot function correctly unless it is worn properly.

Seat belts reduce certain risks under certain conditions. They do not prevent occupant contact with the interior or the exterior in all circumstances. In near side impacts (against the side of your Grenadier on which you are sitting), they cannot prevent contact with the interior at all.

Your Grenadier has pretensioners and load limiters on the front seat belt assemblies. The Pretensioner pulls webbing onto the retractor to snag the seat belt in the first milliseconds of a crash to attempt to

# SEATS, SEAT BELTS, CHILDREN IN CAR SEATS & BOOSTER SEATS, & AIR BAGS

---

increase seat belt effectiveness. Load limiters will allow the retractor to release webbing late in a crash when the load on the webbing (and the occupant) exceeds certain levels. That reduces the risk of injuries from seat belt loading. After a crash, the belt might seem loose. After a severe crash, it may seem very loose. That is not a sign of a problem. That is a sign that the load limiter did its job of reducing chest loads, neck loads, and the risk of injury.

## After a crash

If your Grenadier has been in a crash, have the seat belts inspected by your INEOS dealer and replaced if the pretensioners deployed or there was damage to the webbing or any other component.

## Cleanliness

Do not use bleach or chemicals to clean seat belt webbing. They can degrade and weaken the webbing, and that can reduce the ability of the seat belt to manage the forces of a crash. They can even cause the webbing to part under load.

Do not place anything or allow anything to get into a seat belt buckle other than the tongue of a latch plate. Do not use liquids of any kind to clean the inside of a buckle. Do not allow liquids, food, coins, or debris to get into a buckle. Liquids can cause many different problems (e.g., damage lubricants, congeal and interfere with the buckle's operation, attract and hold debris). Objects can interfere with the movement of the latching mechanism or the push button.

If you are concerned about the cleanliness of a buckle, have it inspected and if necessary replaced by your INEOS dealer.

## Seat belt warnings

- > The driver must always ensure that all occupants are belted properly before driving, and that they all remain belted properly while driving. Failure to do so could lead to serious injury and death.
- > Position the shoulder belt away from the neck and over the collar bone and chest. Failure to properly position the shoulder belt could lead to serious injury and death.
- > Position the lap belt low and tight across the hips. Do not let it pass above the hips or over the abdomen. Failure to properly position the lap belt could lead to serious injury and death.
- > Even when properly worn and properly maintained, seat belts cannot prevent all injuries in all crashes. They can reduce the risk of certain injuries in certain crashes.
- > Do not use a seat belt that has twisted webbing. Straighten the webbing so that it lies flat across bony structures of your body. Wearing twisted webbing can strain the webbing resulting in a malfunction and in serious injury and death.
- > Do not use a seat belt that is malfunctioning. If a seat belt is malfunctioning, move to a seating position with an operable seat belt, bearing in mind all of the other warnings and precautions of this manual. If there is no available seating position with an operating seat belt, find other transportation. Riding unrestrained without a seat belt can lead to serious injury and death.

# SEATS, SEAT BELTS, CHILDREN IN CAR SEATS & BOOSTER SEATS, & AIR BAGS

- > Do not use aftermarket parts such as extenders, clamps, or cushions. They can impair the effectiveness of your seat belt resulting in serious injury and death.
- > Have your seat belts inspected and replaced if appropriate after a crash.
- > If it is necessary to replace a seat belt, air bag, or other safety system on this vehicle, it **MUST** be replaced with INEOS approved parts. The safety components in your Grenadier are specifically designed for each seating position. Failure to use INEOS approved parts may result in serious injury and death.
- > Do not use chemicals or solvents on the seat belt webbing. Failure to heed this warning could lead to a malfunction and to serious injury and death.
- > Do not allow anything other than the tongue of a latch plate to go into a seat belt buckle. Failure to heed this warning could lead to a malfunction and to serious injury and death.
- > If you notice cuts or holes on any seat belt webbing, have that seat belt replaced by an INEOS dealer immediately. Damaged webbing may not hold under load, resulting in a malfunction and in serious injury and death.

## CHILDREN IN CAR SEATS AND BOOSTER SEATS

### Introduction

Your Grenadier's seat belts are designed to be worn by adult-sized occupants rather than children.

To secure children, you must use a supplemental seat of your own choosing. Different organizations and jurisdictions use different terminologies for these. Generally speaking, there are three types for three stages of child growth:

- > Rear-Facing Car Seats (with built-in seat belts) for infants and very small toddlers;
- > Forward-Facing Car Seats (with built-in seat belts) for toddlers who have outgrown Rear-Facing Car Seats; and
- > Booster Seats for children who have outgrown Rear-Facing and Forward-Facing Car Seats, but are not large enough to fit safely and comfortably in your Grenadier's seat belts.

Take time to learn about these options by visiting NHTSA's web site at <https://www.nhtsa.gov/equipment/car-seats-and-boosters>, the Center for Disease Control's (CDC's) web site at <https://www.cdc.gov/injury/features/child-passenger-safety/index.html>, the Insurance Institute for Highway Safety's web site at <https://www.iihs.org/topics/child-safety>, and the SafeKids web site at <https://cert.safekids.org/get-car-seat-checked>. SafeKids has a Certified Technician's program; you can learn about that by visiting <https://portalskcms.cyzap.net/dzapps/dbzap.bin/apps/assess/webmembers/secure/manage?webid=SKCMS&pToolCode=CERT-SEARCH&pAdd=Yes>. You can

## SEATS, SEAT BELTS, CHILDREN IN CAR SEATS & BOOSTER SEATS, & AIR BAGS

---

also consult your local motor vehicle department or division, or your local police.

There are many such car seats on the market. There are many manufacturers of such seats. Each of those seats has different functions, capacities, and limitations. Each of those manufacturers has different instructions and precautions in its manuals. They use different terms to describe them. INEOS cannot advise you on which car seat is right for your child or for the jurisdiction in which you are driving. However, you must choose a seat that (1) fits your child and secures your child in place and (2) allows you to comply with applicable laws where you are driving. And you must follow the instructions and precautions provided by the car seat manufacturer.

We recommend that you buy a new car seat, not a used one. Used car seats may be damaged. Car seat technology improves year by year, too.

If you have questions about which seat is legal, check with your state government's motor vehicle division or other authority. For assistance with selecting the right seat and seat fit for your child, there are various sources, including NHTSA's Car Seat Finder on its web site: <https://www.nhtsa.gov/equipment/car-seats-and-booster-seats> . You can also call **NHTSA at 888-327-4236** .

If you want help with installing a child or booster seat, or to confirm that a particular seat is legal and is right for your child, you can consult your local authorities. Most states and local police departments will inspect your child or booster seat and its installation for safety.

### **Whenever possible, secure children in one of the rear seating positions, not the front seat**

According to accident statistics, children are safer when properly restrained in the rear seating positions than in the front seating positions.

Rear-Facing Car Seats must never be placed in the front passenger seat. Such seats can be caught by a deploying air bag and flung rearward. They are incompatible with the front seat air bag. Placing a Rear-Facing Car Seat in your Grenadier's front seat could lead to serious injury and death.

There are two means of securing Rear-Facing and Forward-Facing Car Seats to your Grenadier:

- > A LATCH (ISOFIX) system at each of the two rear outboard seating positions for use only with Rear-Facing Car Seats; and
- > Your Grenadier's seat belts at each of the three rear seating positions (and in the front passenger seat in case of an emergency);

Car seat Upper Tethers should be used for all Forward-Facing Car Seats in addition to one of the two methods above. There is a car seat Upper Tether hook on the back of each rear seat.

Every Rear-Facing and Forward-Facing Car Seat needs to be installed using either the lower anchors or a seat belt to secure it in place, never both.

## SEATS, SEAT BELTS, CHILDREN IN CAR SEATS & BOOSTER SEATS, & AIR BAGS



**WARNING:** Failure to follow these instructions and precautions may result in serious injury and death.

### Securing a Rear-Facing or Forward-Facing Car Seat to your Grenadier with the LATCH (ISOFIX) lower tethers

The two rear outboard seating positions are equipped with LATCH-type (ISOFIX) anchor rings shown below (A). These may be used for Rear-Facing Car Seats. There are two anchors for the right rear seat, and two for the left rear seat. They are located between the bottom cushion and the seat back in each of the two outer rear seats.

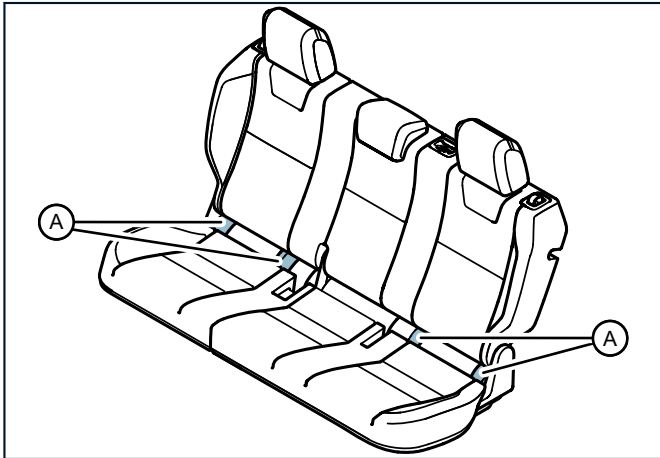

Each anchor location is marked with this symbol:



The LATCH (ISOFIX) anchors are not meant to be used when the total mass of the child and car seat exceed 73 lb. (33 kg.) . They may not hold greater weights. If the combined weight (mass) exceeds 73 lb. (33 kg.) , use your Grenadier's seat belt, not the LATCH (ISOFIX) to secure it.

To install a car seat using the lower anchors:

- > Read all of the car seat manufacturer's instructions and precautions first, and follow them all throughout this process.
- > Place the car seat on one of the two outer rear seating positions of your Grenadier.
- > Make sure that it is centered left-to-right in that seating position, that it is straight (not at an angle), that it is on the seat bottom (rather than a towel, pad, etc.), and that the car seat is pushed as far rearward toward the seat back as possible.
- > Secure the car seat to the Grenadier's lower anchors according to the car seat manufacturer's instructions.



## SEATS, SEAT BELTS, CHILDREN IN CAR SEATS & BOOSTER SEATS, & AIR BAGS

---

- > Press the car seat firmly downward and toward the rear while tightening its anchor straps according to the manufacturer's instructions.
- > Check to make sure that the seat is secured by attempting to move it side to side and forward and rearward. If it can be moved more than an inch in any direction, tighten it more.
- > If you have difficulty securing the seat, seek professional help from your local motor vehicle division, police, or sheriff, or from the resources mentioned above in the Introduction to this section on Children, Car Seats, and Booster Seats.
- > For forward-facing car seats, the Upper Tether is also required (see Securing a Car Seat Upper Tether to your Grenadier).

Do not attempt to secure a car seat in the center rear seat by using the lower anchors. Anchor spacing is crucial for child safety. Never use anchors from the outer seats for the center position.

Never share anchors with more than one car seat. Each anchor should be attached to only one car seat anchor attachment.



**WARNING: Failure to follow these instructions and precautions may result in serious injury and death.**

### Securing a Rear-Facing or Forward-Facing Car Seat to your Grenadier with your Grenadier's seat belts

All child restraint systems are designed to be secured in vehicle seats by lap belts or the lap belt portion of a lap-shoulder belt. Children could be endangered in a crash if their child restraints are not properly secured in your Grenadier.

To install a car seat using the seat belt:

- > Read all of the car seat manufacturer's instructions and precautions first, and follow them all throughout this process.
- > Place the car seat in one of the three rear seating positions in your Grenadier.
- > Make sure that it is centered left-to-right in that seating position, that it is straight (not at an angle), that it is on the seat bottom (rather than a towel, pad, etc.), and that the car seat is pushed as far rearward toward the seat back as possible.
- > If the car seat has an Upper Tether on its upper back, flip that over to the front so you can get to it later.
- > Thread the seat belt through the car seat according to the car seat manufacturer's instructions, ensuring the belt is straight without any twists.
- > Buckle the seat belt, listening for a click to confirm it's secure. Confirm that it is latched by trying to pull the latch out with the belt.

## SEATS, SEAT BELTS, CHILDREN IN CAR SEATS & BOOSTER SEATS, & AIR BAGS

- > Fully extend the upper (shoulder) webbing out all the way, smoothly and steadily, to set the pre-lock ALR function.
- > Let the seat belt retract. As it does, you should hear clicks, indicating the pre-lock ALR function is set.
- > Press the car seat firmly downward and toward the rear while letting the upper (shoulder) webbing retract and lock.
- > Make sure the seat belt is locked by trying to pull the webbing out of the retractor. If it extends, unbuckle it, and repeat the above steps.
- > For forward-facing car seats, the Upper Tether is also required (see Securing a Car Seat Upper Tether to your Grenadier).



**WARNING: Failure to follow these instructions and precautions may result in serious injury and death.**

### Securing a Car Seat Upper Tether to your Grenadier

Always use one of the two methods described in the previous two sections to secure a car seat; an Upper Tether alone is not safe! For Forward-Facing Car Seats, the Upper Tether provides additional stability and limits the forward movement of the car seat during a crash, helping to reduce the risk of head and neck injuries.

If the car seat is forward-facing and has an Upper Tether, secure it to the Grenadier's Upper Tether anchor. All three rear seating locations are equipped with car seat Upper Tether anchorages. To secure a

car seat to an Upper Tether anchor, follow the manufacturer's guidelines and:

- > Route the Upper Tether strap under the head restraint between the head restraint posts and over the back of the seat. Do not route the Upper Tether over the head restraint. Pull the head restraint upward or remove it as required to route the Upper Tether over the seat back itself.
- > Locate the Upper Tether anchor on the back of each rear seat. The Upper Tether anchor points are marked with the symbol  .
- > Clip the Upper Tether strap to the anchor on the back of the same seat. Check that the Upper Tether strap is not twisted.
- > Tighten the Upper Tether strap according to the car seat manufacturer's instructions.
- > Use only the Upper Tether on the back of the seat in which the car seat is positioned. Never put more than one Upper Tether on an anchor.
- > Check to make sure that the seat is secure by attempting to move it side to side and forward and rearward. If it can be moved more than an inch in any direction, tighten it more.

## SEATS, SEAT BELTS, CHILDREN IN CAR SEATS & BOOSTER SEATS, & AIR BAGS

- > If you have difficulty securing the seat, seek professional help from your local motor vehicle division, police, or sheriff, or from the resources mentioned above in the Introduction to this section on Children, Car Seats, and Booster Seats.

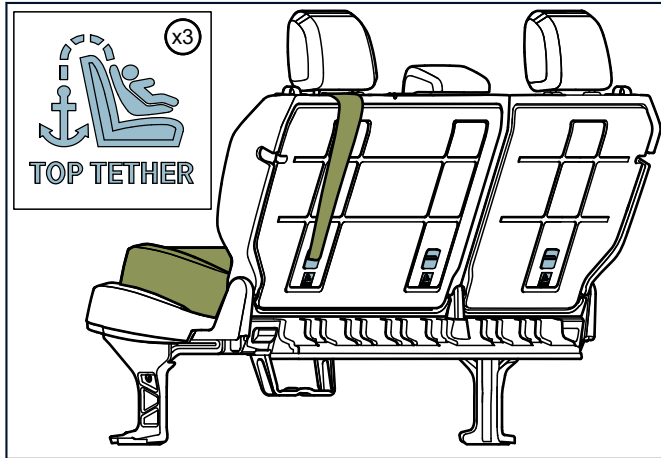

To release a pre-locked seat belt:

- > Hold the seat belt and push the red buckle release button.
- > Guide the seat belt webbing as it retracts to the stored position.

- > The pre-lock ALR function will then be disabled and you can pull the webbing out again.



**WARNING:** Failure to follow these instructions and precautions may result in serious injury and death.

### Securing a Forward-Facing Car Seat to your Grenadier's front seat

You must never secure a Rear-Facing Car Seat to your Grenadier's front seat. But if you face an emergency and have no choice but to place a Forward-Facing Car Seat in your Grenadier's front seat, follow these instructions:

- > Read all of the car seat manufacturer's instructions and precautions first, and follow them all throughout this process.
- > Place the car seat in the front passenger seat in your Grenadier.
- > Make sure that it is centered left-to-right in that seating position, that it is straight (not at an angle), that it is on the seat bottom (rather than a towel, pad, etc.), and that the car seat is pushed as far rearward toward the seat back as possible.
- > Thread the seat belt through the car seat according to the car seat manufacturer's instructions, ensuring the belt is straight without any twists.

## SEATS, SEAT BELTS, CHILDREN IN CAR SEATS & BOOSTER SEATS, & AIR BAGS

- > Buckle the seat belt, listening for a click to confirm it's secure. Confirm that it is latched by trying to pull the latch out with the belt.
- > Fully extend the upper (shoulder) webbing out all the way, smoothly and steadily, to set the pre-lock feature.
- > Let the seat belt retract. As it does, you should hear clicks, indicating the pre-lock ALR function is set.
- > Press the car seat firmly downward and toward the rear while letting the upper (shoulder) webbing retract and lock.
- > Make sure the seat belt is locked by trying to pull the webbing out of the retractor. If it extends, unbuckle it, and repeat the above steps.
- > Check to make sure that the seat is secured by attempting to move it side to side and forward and rearward. If it can be moved more than an inch in any direction, tighten it more.
- > If you have difficulty securing the seat, seek professional help from your local motor vehicle division, police, or sheriff, or from the resources mentioned above in the Introduction to this section on Children, Car Seats, and Booster Seats.
- > After the installation of the car seat and child, the Passenger Airbag will deactivate. If the passenger airbag lamp indicating ON is still illuminated the airbag is still active.

As soon as the emergency is over, relocate the Forward-Facing Car Seat to one of the rear seats and secure it properly.



**WARNING:** Failure to follow these instructions and precautions may result in serious injury and death.

### Front passenger classification system

Your Grenadier includes a system in the front passenger seat that uses sensors to detect the shape and mass of an occupant in the front passenger seat, activating the air bag for adult-sized occupants and deactivating it for others, including children.

The system works as designed when the occupant is properly seated as described above and when nothing is interfering with the sensors or their wiring.

The system's sensors cannot detect a person's actual age.

Even with this technology, you must never install a rear-facing child seat in the front passenger seat and you should not place children in a front seating position.

The passenger airbag lamps (1) are located on the overhead control panel and are shown below. During the start up of the vehicle all the passenger airbag lamps will be illuminated as the vehicle is self-testing.

If the passenger airbag is enabled after the self-testing has finished, then the "ON" lamp (1) will be illuminated for a few seconds before turning off.

If the passenger airbag is disabled after the self-testing has finished, then the "OFF" Lamp (3) will be illuminated and will remain illuminated until the classification system detects an adult-sized

## SEATS, SEAT BELTS, CHILDREN IN CAR SEATS & BOOSTER SEATS, & AIR BAGS

occupant properly seated in the front passenger seat and the air bag is enabled.

The text “PASSENGER AIR BAG” (2) is always illuminated while the engine is running.

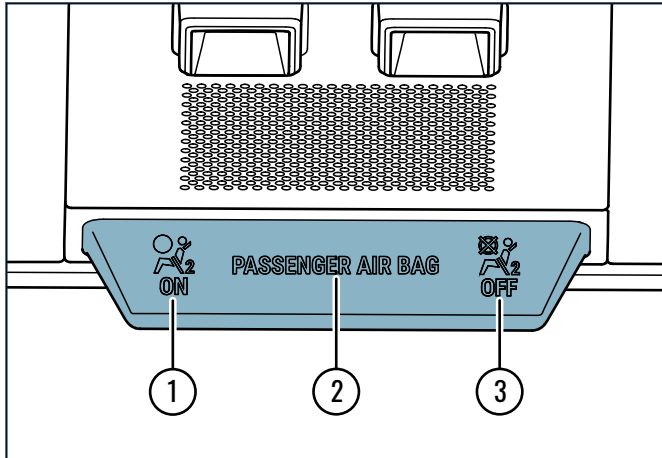

If the air bag is disabled while an adult is in the seat, make sure they are properly seated (refer to “Sitting in a Safe Position”) and check that no objects are trapped beneath the seat.

If the air bag is enabled while a child is in a child seat installed on the seat, remove the child seat and reinstall it per the child seat manufacturer’s instructions.



**WARNING:** If the Passenger Air Bag lamp on the Overhead Control Panel is OFF when you believe it should be ON, consult your INEOS dealer immediately. Do not drive with anyone in the front passenger seat until it has been inspected. The system may not operate correctly in a crash, resulting in serious injury or death.

### Securing your child into a Rear-Facing or Forward-Facing Car Seat

Securing the Rear-Facing or Forward-Facing Car Seat to your Grenadier is only part of the job. The job isn't finished until the child is secured to the car seat. Each car seat's restraint system is different. Follow the manufacturer's instructions and precautions to make sure that your child is snugly secured to the car seat. If you have questions about how to do this or have difficulty securing the child in the seat, seek professional help from your local motor vehicle division, police, or sheriff, or from the resources mentioned above in the Introduction to this section on Children, Car seats, and Booster Seats.



**WARNING:** Failure to follow these instructions and precautions may result in serious injury and death.

### Booster seats

Booster seats are for children who have outgrown car seats. Such children need a Booster Seat if your Grenadier's seat belt doesn't fit snugly across their shoulder and lap, avoiding the neck and face, usually until they are over 12 years old. Booster seats elevate and

## SEATS, SEAT BELTS, CHILDREN IN CAR SEATS & BOOSTER SEATS, & AIR BAGS

---

position a child so that your Grenadier's seat belt can be routed safely over the child, reducing the risk of injury during a crash.

Make sure that your child does not fall outside the weight and height limits specified by the booster seat manufacturer.

Booster seats are best used in a rear seating position. If you have four children in your Grenadier, choose to put the Booster Seat, and not a Rear-Facing or Forward-Facing Car Seat, in the front seating position.

To secure a child in a Booster Seat:

- > Read all of the Booster Seat manufacturer's instructions and precautions first, and follow them all throughout this process.
- > Place the Booster Seat in the front passenger seat in your Grenadier.
- > Make sure that it is centered left-to-right in that seating position, that it is straight (not at an angle), that it is on the seat bottom (rather than a towel, pad, etc.), and that the Booster Seat is pushed as far rearward toward the seat back as possible.
- > Thread the seat belt through or around the Booster Seat according to the Booster Seat manufacturer's instructions, ensuring the belt is straight without any twists.
- > Buckle the seat belt, listening for a click to confirm it's secure. Confirm that it is latched by trying to pull the latch out with the belt.

- > Make sure that the shoulder belt is routed over the child's collar bone and chest—not the neck—and under the arm closest to the buckle.
- > Make sure that the lap belt is low and tight across the child's hips, not over the abdomen.
- > If the seat belt cannot fit properly, your child may need to be in a Forward-Facing Car Seat instead.



**WARNING: Failure to follow these instructions and precautions may in serious injury or death.**

### A child's preference

Sometimes, a child may resist being in Forward-Facing Car Seats or Booster Seats and may think they are too “grown up” for them. Do not let your child make adult decisions. What is important is not how “grown-up” your child wants to be, but how large your child actually is. If you allow a child to ride in a restraint that does not fit or is not proper for the child's size, you risk serious injury and death to that child.

### Sleeping and moving children

Make sure that all occupants remain properly belted throughout your drive. Children may move or fall asleep and end up with a seat belt improperly positioned, particularly if it was not snugly and properly positioned to begin with. Check the children periodically. If you find that one or more is not properly belted, pull over and re-route the seat belt to make sure that the child is properly belted.

## SEATS, SEAT BELTS, CHILDREN IN CAR SEATS & BOOSTER SEATS, & AIR BAGS



**WARNING:** Failure to follow these instructions and precautions may in serious injury or death.

### Children in Car Seats and Booster Seats warnings



**WARNING:**

- > The driver must always make sure that all occupants are belted properly before driving, and that they all remain belted properly while driving. Failure to do so could lead to serious injury and death.
  - > Every occupant must be restrained properly in a seat, Car Seat, or Booster Seat as is appropriate for that occupant's size. Failure of an occupant to be restrained could result in serious injury and death to that occupant and to other occupants who may be struck by the unrestrained occupant.
  - > According to accident statistics, children are safer when properly restrained in the rear seating positions than in the front seating positions. Allowing a child to ride in a front seating position could lead to serious injury and death.
  - > Never place a Rear-Facing Car Seat in the front passenger seat. Such seats can be caught by a deploying air bag and flung rearward. They are incompatible with the front seat air bag. Placing a Rear-Facing Car Seat in your Grenadier's front seat could lead to serious injury and death.
- > Make sure that all Rear-Facing and Forward-Facing Car Seats are secured to your Grenadier. An unsecured or poorly secured Car Seat can become a projectile. An unsecured or poorly secured Car Seat cannot properly secure its occupant. Failure to heed this warning could result in serious injury and death.
  - > Do not exceed the load limits of the LATCH (ISOFIX) or Tethers. Doing so could result in serious injury and death.
  - > Make sure that your Grenadier's seat belts are not routed over the neck or abdomen. Make sure that the shoulder belt is routed over the collar bone and chest and under the arm closest to the buckle. Make sure that the lap belt is routed low and tight across the hips, and not the abdomen. Failure to heed these warnings could result in serious injury and death.
  - > There is no anti-pinch feature on the rear windows. It will keep moving and applying pressure even if an object or body part (e.g., finger, hand, head, neck) is in the way. Make sure that the window opening is clear before rolling up a rear window. Never allow children to remain in your Grenadier unattended with the ignition in ACC (Accessory) or ON. Always supervise children's use of windows.

# SEATS, SEAT BELTS, CHILDREN IN CAR SEATS & BOOSTER SEATS, & AIR BAGS

---

- > Make sure that the child lock is on when a child is positioned next to or with access to a rear side door. (See Doors and Windows.)

## AIR BAGS

### Air bag system overview

Your Grenadier is equipped with an air bag and lap/shoulder belt at both front seating positions. The air bag is a supplemental restraint at those seating positions. All occupants must always wear their seat belts whether or not an air bag is also provided at their seating positions to minimize the risk of severe injury or death in the event of a crash.

All occupants must be properly positioned as described in the Seat and Children in Car Seats and Booster Sections above.

Do not place any objects over or near the air bag on the instrument panel; any such objects could cause harm in the event of a deployment.

The system consists of:

- > Driver and front passenger safety belts with pretensioner(s) and load limiting systems.
- > Rear seat belts.
- > Dual stage driver and passenger airbags.
- > Curtain airbags on both sides of the vehicle.

- > Thorax airbags both sides of the vehicle (Driver and front passenger only).
- > Knee airbags (Driver and front passenger only).
- > Front passenger classification system.
- > Air Bag Control Module (ACM).

The ACM uses sensor data collected during a crash to determine whether and how to deploy air bags and seat belt pretensioners.

Air bags and pretensioner will not deploy in every crash. If there is no deployment, that does not mean there is something wrong with the system. It means that the sensor data did not meet the ACM's criteria for deployment.

The airbag locations in the vehicle are highlighted by an "AIRBAG" imprint or marker in four locations around the interior.



# SEATS, SEAT BELTS, CHILDREN IN CAR SEATS & BOOSTER SEATS, & AIR BAGS

Station Wagon:

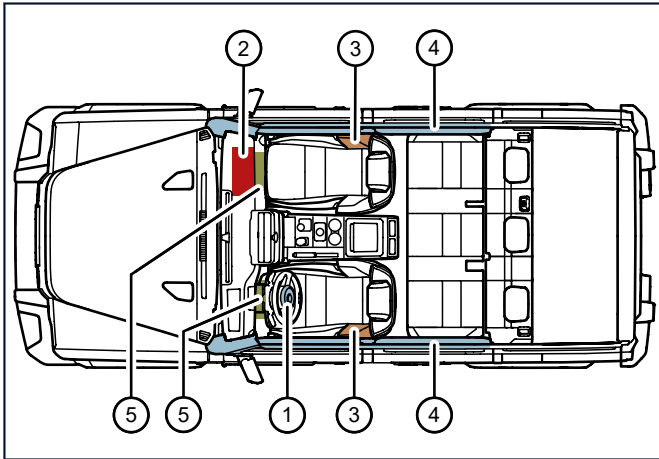

Quartermaster:

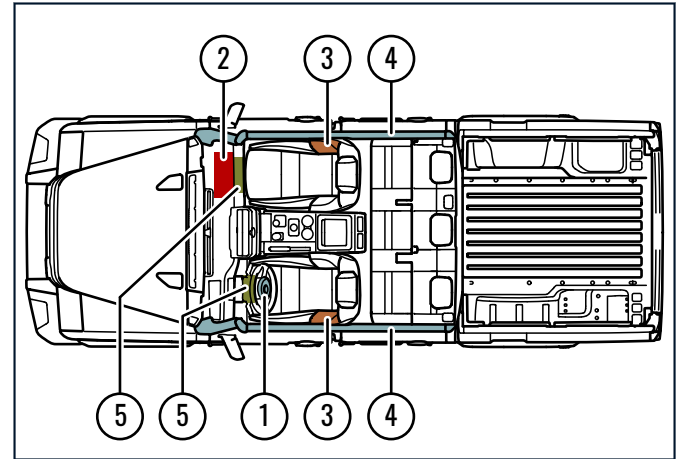

**Frontal air bags.** The driver's air bag (1) is in the steering wheel, and the front passenger's air bag (2) is above the glove compartment. These air bags deploy in front of the driver and front seat passenger to reduce the risk of injury to the head, neck, face, chest, and legs in severe frontal or near-frontal collisions.

**Side air bags.** Located inside the driver and front passenger seat backs, side air bags (3) deploy between a front seat occupant and the

# SEATS, SEAT BELTS, CHILDREN IN CAR SEATS & BOOSTER SEATS, & AIR BAGS

door to reduce the risk of injury to the thorax in severe impacts to the near side.

**Curtain air bags.** Located inside the roof trim, curtain air bags (4) deploy adjacent to the upper door and window glass in both seating rows to reduce the risks of head injuries and of partial or complete ejection during rollovers, certain severe side impacts and in certain frontal collisions with lateral movement.

**Knee air bags.** Located under the dashboard, knee air bags (5) deploy in front of the driver and front seat passenger to reduce the risk of injury to the knees and legs in a severe frontal or near-frontal collisions.

When you switch your Grenadier's ignition on, the air bag warning

light  in the Telltale Cluster will show for about 10 seconds during a system self-test. If the light stays on or reappears while driving, there's an issue with the air bag system. The Center Display and Touchscreen will send a related warning message.

If the air bag warning light is displayed  or an air bag warning message is displayed on the Center Display and Touchscreen, even intermittently, contact an INEOS dealer immediately. Do not drive your Grenadier until it has been repaired. The system may not operate correctly in a crash, resulting in serious injury and death.

Air bags deploy according to the type and severity of the crash. They will not deploy in all crashes.

## ADDITIONAL AIR BAG WARNINGS



### WARNING:

- > The driver should keep the hands on the wheel and not allow an arm or anything else to pass over the air bag. A deploying air bag can contact an arm or object rearward, resulting in serious injury and death.
- > Keep air bag areas clear. Deploying air bags can turn items into projectiles, risking serious injury and death. Never hang items from roof handles; curtain air bags can launch them. Don't attach anything to or cover the steering wheel air bag. Keep the dashboard/instrument panel free of objects.
- > Air bags inflate forcefully within a few thousandths of a second. There is a risk of death or serious injury from air bags. Never sit closer to the air bags than necessary. Be aware of the locations of the side and curtain air bags and never lean against doors or windows. Never ride with your feet on the dashboard or out the window.
- > Do not place aftermarket seat covers on seats. They may interfere with the deployment of a side air bag, depriving an occupant of the benefit of the air bag resulting in serious injury and death.

## SEATS, SEAT BELTS, CHILDREN IN CAR SEATS & BOOSTER SEATS, & AIR BAGS

---

- > When air bags deploy, smoke and dust released can irritate the skin and eyes. The sound might temporarily affect hearing. Direct skin contact with a deploying air bag can result in minor abrasions. Components of the air bag can also be hot, posing a burn risk. If you are injured, seek medical attention immediately.
- > Never attempt to drive your Grenadier after the air bags have deployed. Your Grenadier must be repaired before it is used.
- > If it is necessary to modify the air bag system for persons with disabilities, contact an INEOS dealer.
- > Air bags do not guard against every injury. A person can still be injured notwithstanding an air bag deployment depending a variety of factors.

# CARGO LOADING AND SECURING

---

OVERVIEW .....	94
CARGO AREA (Station Wagon Only) .....	95
LOADBAY (Quartermaster Only) .....	96
LOADBAY UTILITY RAILS (if equipped) .....	97
ROOF LOADING .....	97
TRAILER AND HITCH-MOUNTED DEVICES .....	98
OTHER DEVICES INAPPROPRIATE FOR CARRYING CARGO WHILE DRIVING .....	98

# CARGO LOADING AND SECURING

## OVERVIEW

Your Grenadier has certain capacities for carrying cargo. Its Gross Vehicle Weight Rating is 7,716 lb. (3,500 kg.) . Its curb weight starts at 5,826 lb. (2,643 kg.) , inclusive of 90% fuel and fluids but no driver (vehicles fitted with options and accessories may have a higher curb weight than this). That means that it can carry up to 1,889 lb. (857 kg.) . That includes all cargo and occupants, including the driver. Before adding cargo, deduct the weight of the driver and occupants from the 1,889 pound number first, then add no more weight than the remaining capacity. For example, if the driver weighs 200 pounds and the occupants weigh another 400 pounds , you have 1,289 pounds of cargo capacity remaining (1,889 – 200 – 400 = 1,289) .



**NOTE:** *You must consider the burden of the trailer in your cargo calculations. Your Grenadier's original equipment trailer hitch can support up to 771 lb. (350 kg.) . Deduct that along with the weight of the driver and occupants in your calculations of remaining cargo capacity.*

When carrying cargo in or/and on your Grenadier, make sure that:

- > The cargo is enclosed in a container (e.g., box, bag, netting) that is sufficient to keep it together in normal driving and a crash.
- > The cargo is placed as low as possible in the selected area.
- > The cargo is secured to your Grenadier with devices that are sufficient (in terms of location, number and strength) to keep it in place during normal driving and a crash.

- > You check the security of your cargo and its tie-downs before driving and that you stop and check it periodically after starting your journey.
- > Comply with local laws (some jurisdictions have limits).

Do not store cargo where it can interfere with the driver(e.g., by falling or sliding into the footwell, including from under the driver seat).

You will need to supply your own devices (e.g., straps, rope, cords) to secure any cargo. You will also need to supply your own means of containing the cargo.

During a crash, the effective weight of cargo can increase up to 30 times or more. An object that weighs 10 pounds can have the effective mass of around 300 pounds . Figure this into your calculations when selecting your tie-down devices.

Uncontained cargo can come loose in cornering, braking, accelerating, and crashes. Loose cargo can strike and injure someone during normal driving. It can distract the driver. In a crash, it can become a projectile and strike someone.

Never use a seat belt to secure cargo. Seat belts are not designed for that.

The heavier the load:

- > The more your Grenadier's handling and stability is reduced.
- > The longer it takes to slow or stop your Grenadier.
- > The longer it takes to accelerate your Grenadier.

# CARGO LOADING AND SECURING

---

Get used to the changes in handling and stability when you start carrying a heavy load and adjust your driving accordingly.

The higher the cargo is relative to the vehicle's center of gravity, the more it reduces your Grenadier's handling and stability. That condition worsens in windy conditions, on winding roads, and off road. Get used to the changes in handling and stability when you start carrying higher loads or loads on the roof and adjust your driving accordingly.

Putting cargo on only one side of your Grenadier can also affect its handling and stability.

Adjust tire pressures to accommodate the added weight of the load.

Carrying cargo high in or on top of your Grenadier increases the risk of loss of control, if rollover, and of serious injury and death.

Unsecured or poorly secured cargo can come off your Grenadier result in danger to others, driver distraction, a desire to stop near the road for retrieval, and can lead to serious injury and death.



**WARNING: Failure to follow the instructions and precautions above may result in serious injury and death.**

## CARGO AREA (Station Wagon Only)

The first choice for carrying cargo must be the cargo area, which is in front of the 30/70 doors and behind the rear seats.

Your Grenadier may be equipped with Interior Utility Rails located on the floor of the cargo area and four Quick Release Tie-Down Rings, which slot into the pre-defined locations along the rail. Accessories such as the Cargo Management System can be attached to these rails. There are other tie-down locations in the cargo area as well.

Never rely on a seat back or the base(s) of the folded-up rear seat(s) to secure cargo. They are not designed to support cargo or to keep it from sliding forward. In a crash, the momentum of the cargo could overload the seat and crush occupants in front of the seat back.

All of your remaining cargo capacity can be placed in the cargo area; the only other limitations are dimensional (width, length, height).

Whenever possible, avoid storing cargo higher than the nearest seat back. Cargo placed higher than that can obstruct the driver's field of vision. And there is an increased risk that higher cargo will become a projectile in a crash.

Do not allow cargo (e.g., boards) to protrude forward of the cargo area and into seating areas. Such cargo can move during cornering or a crash, increasing the risk of distraction, serious injury, and death.

If you must carry cargo that protrudes beyond the rear of the cargo area, make sure to:

- > Secure it so that it will not slide out.
- > Hang a signal (e.g., red flag) on the end as required by local law.
- > Let it protrude no more than local law allows.
- > Keep one or both of the 30/70 doors from obscuring a taillight.

# CARGO LOADING AND SECURING



## WARNING:

- > Failure to follow the instructions and precautions above and in the Overview subsection may result in serious injury and death.
- > Your cargo area is part of the crush zone in the event your Grenadier is hit from behind. In a rear impact, the cargo in the cargo area can be shoved forward as the crush zone responds to an impact. That can increase the risk of serious injury and death to occupants.

## LOADBAY (Quartermaster Only)

The first choice for carrying cargo is the Loadbay.

Cover the Loadbay floor to protect it from scraping and harmful fluids. Avoid focal loads; the floor can be dented.

Place heavier cargo as close to the bed floor and as far forward as possible. If at all possible, do not obscure the driver's view out the rear glass or the center high mounted stop lamp at the top rear of the occupant compartment.

Be aware that cargo carried high in the Loadbay can be pushed forward through the rear glass in a rear impact, resulting in death or injury to occupants. This is especially dangerous if the cargo protrudes beyond the rear of the Loadbay.

When carrying more than one item of cargo, distribute the load evenly from side to side.

Be mindful of the weight limitations for your vehicle and for the rear axle. Do not forget to include the tongue weight of an attached trailer or cargo carrier.

If cargo must extend onto or beyond the tailgate, make sure to:

- > Secure it so that it will not slide out.
- > Hang a signal (e.g., red flag) on the end as required by local law.
- > Let cargo protrude as little as possible, never more than local law allows.

Never let passengers ride in or on the Loadbay or tailgate. They may fall off or out. They will be unsecured in crashes. All passengers must be in seats and seat belts whenever the vehicle is in motion.

Do not carry animals in the Loadbay except in secured carriers.

Be sure that all objects in the Loadbay are secured before you begin driving. Cover them as appropriate and as required by local laws with a secured object designed for that purpose (e.g., netting, tarp). Loose cargo cannot be kept within the bed by the sides and tailgate. It may be thrown, bounced, or blown out. It will become projectiles in the event of a sudden stop or crash. The Loadbay is equipped with Utility Rails and four Quick Release Tie-Down Rings, which slot into pre-defined locations along the rail. Do not exceed their capacities in normal driving or in a crash.

Drive slowly when starting off after securing and covering cargo. Be sure that the attachments are holding and that the vehicle does not feel unsteady. Loose objects can leave the Loadbay. They can distract the driver. Resecure, reorganize, or remove cargo as needed to ensure a safe, secure ride.

# CARGO LOADING AND SECURING



## WARNING:

- > Failure to follow the instructions and precautions above and in the 'Overview' subsection may result in serious injury and death.
- > Do not allow people to ride in any area of your vehicle that is not equipped with seats and seatbelts. Make sure everyone in your vehicle is in a seat and properly using a seatbelt. Failure to follow this warning could result in serious personal injury or death.
- > Your Loadbay area is part of the crush zone in the event your Grenadier is hit from behind. In a rear impact, the cargo in the Loadbay area can be shoved forward as the crush zone responds to an impact. That can increase the risk of serious injury and death to occupants.

## LOADBAY UTILITY RAILS (if equipped)



**WARNING: Ensure equipment in the loadbay is secure, users should not load the vehicle, any options or accessories (or any part of them) beyond their intended capacities. Improper use of the vehicle or other equipment may be unsafe and could result in property damage and/or injury to users and/or other parties.**

The Loadbay Utility Rails are located in the loadbay of the Quartermaster. They are supplied with four Quick Release Tie-Down Rings, which slot into the pre-defined locations along the LoadBay Utility Rail.



*NOTE: Each Loadbay Utility Rail and each Quick Release Tie-Down Ring can withstand a force of 3.5 kN. The minimum distance between the Quick Release Tie Down Rings per Loadbay Utility Rail has to be 700 mm. If more than one tie down is installed with a distance less than 700mm, the force of 3.5 kN has to be divided between those tie downs, in total the maximum force is 3.5 kN.*

## ROOF LOADING

The full length INEOS Roof Rack accessory (not including its own weight) can accommodate up to 330 lb. (150 kg.) of the remaining cargo capacity while driving and up to 925 lb. (420 kg.) while parked. Why the difference? When you are camping, you may wish to move cargo from the cargo area to the roof. When driving, loads placed on the roof exert a high roll force on the vehicle due to their distance from the center of gravity. Loads greater than 330 lb reduces handling and stability beyond safe limits.

The capacities of the 6-foot INEOS roof rack accessory and the Quartermaster 6-foot INEOS roof rack accessory are lower: 264 lb. (120 kg.) when driving and 826 lb. (375 kg.) when parked.

Only INEOS Roof Rack/Roof Bars accessories are designed to be fixed to the drain gutter.



# CARGO LOADING AND SECURING

Be careful of height clearances when driving with objects on the roof. You may hit an overhead structure (e.g., signs, garage, parking space cover).

If you must carry cargo that protrudes beyond the roof, make sure to:

- > Secure it so that it will not slide off.
- > Hang a signal (e.g., red flag, reflector, light) on the rear, especially if and as required by local law.
- > Let it protrude no more than local law allows.
- > Be careful not to hit anything or anyone with it while driving.

When loading the roof, obey the capacity limitations and think about the positioning of items before securing them in place. The shape, weight and size of the items loaded onto the roof can change the handling characteristics of the vehicle. Plan in advance how everything will be tied down and positioned. Long items such as canoes or surf boards may have some overhang. Remember that this can not only alter the height of the vehicle, but the length too.



## WARNING:

- > Failure to follow the instructions and precautions above and in the Overview subsection could result in serious injury and death.
- > When you have a load on your roof, the risk of injury and death from rollover may be increased. The object on the roof may concentrate the load

of your overturning Grenadier, resulting in localized damage and an increased risk of serious injury and death.

## TRAILER AND HITCH-MOUNTED DEVICES

Your Grenadier can carry cargo on a trailer or a hitch-mounted cargo carrying device. If you elect to use those options remember the capacity limitations mentioned above, as well as those in the Towing a Trailer section. Also abide by the instructions and precautions of the trailer or device manufacturer and local laws.

Never allow cargo on a carrier to obscure your Grenadier's taillights.

## OTHER DEVICES INAPPROPRIATE FOR CARRYING CARGO WHILE DRIVING

The following devices are inappropriate for carrying cargo while driving, including Exterior Utility Belt, Access Ladder and Quartermaster Tailgate

### Exterior Utility Belt (if equipped)

Your Grenadier may have been ordered with the optional Exterior Utility Belt, similar to the Interior Utility Rails that may be on the floor of the cargo area. They run along the vehicle's exterior, including the side, both doors, and beneath the cargo area windows. They come with four Quick Release Tie-Down Rings to attach your gear while your Grenadier is parked. Do not use them to hang gear while under way.

# CARGO LOADING AND SECURING

To use these rings, rotate them to align the point with the clip, press the release button, and slide the clip sideways. This allows for easy adjustment or removal of the tie-down ring along the belt as needed.

LOAD PER HOOK		
	UPPER UTILITY RAIL	LOWER UTILITY RAIL
Front Door	22 lb. (10kg.)	11 lb. (5 kg.)
Rear Door	33 lb. (15 kg.)	22 lb. (10 kg.)
Rear Quarter Panel Q	33 lb. (15 kg.)	N/A

TOTAL LOAD PER RAIL / TETHERING HOOK (DOOR)		
	UPPER UTILITY RAIL	LOWER UTILITY RAIL
Front Door	99 lb. (45 kg.)	33 lb. (15 kg.)
Rear Door	77 lb. (35 kg.)	44 lb. (20 kg.)
Rear Quarter Panel Q	88 lb. (40 kg.)	N/A

Q - Not applicable to the Quartermaster.



## WARNING:

- > The Exterior Utility Belt is not to be used while your Grenadier is being driven. It is only for use when parked.
- > It is not to be used to secure items on the roof.
- > Failure to follow these instructions and precautions may result in serious injury and death.

## Access Ladder (if equipped)

An Access Ladder may be mounted on the back of your Grenadier. The maximum load capacity for the Access Ladder is 330 lbs . It is not for securing cargo. It is for access to the roof.

Never use the Access Ladder unless the 30/70 split doors are completely closed.

Do not use the Access Ladder to secure cargo.



**WARNING: Failure to follow these instructions and precautions could result in serious injury and death.**

\* Not applicable to the Quartermaster.

# CARGO LOADING AND SECURING

---

## Quartermaster Tailgate



**CAUTION:** Do not use the fixation points at the bottom of the tailgate. There is a protective coating to protect the fixing points from corrosion. If a screw and/or fixing is installed and/or removed, then the surface protection will be removed and corrosion may begin. The same applies when removing the Standard Loadbay eyes to use the Accessory Utility Rail.



**CAUTION:** The maximum static load for the Quartermaster tailgate is 496 lbs (225 kg) .

# DRIVING ON ROAD

---

INTRODUCTION .....	102
ENGINE AND POWERTRAIN BREAK-IN .....	102
TURNING ELECTRICAL POWER ON WITHOUT STARTING THE ENGINE .....	102
STARTING AND STOPPING THE ENGINE .....	102
PARKING BRAKE .....	103
POWERTRAIN .....	104
TRANSMISSION CONTROLS .....	104
REVERSE CAMERA .....	110
TIRES AND WHEELS WHILE DRIVING .....	110
DRIVER SUPPORT SYSTEMS .....	114
ADVANCE DRIVER ASSISTANCE SYSTEMS (ADAS) .....	117
WINTER DRIVING .....	126
ROADSIDE EMERGENCIES .....	127
AUTOMATIC CAR WASHES .....	137

# DRIVING ON ROAD

## INTRODUCTION

This section includes information about driving on road. There is a separate section for driving off road.

## ENGINE AND POWERTRAIN BREAK-IN

You must break in the gasoline engine and powertrain for the greatest reliability and performance.

For the first 500 miles (800 km) :

- > Do not overwork the engine in any gear.
- > Do not apply full throttle.
- > Avoid rewing the engine.
- > Avoid fast acceleration and heavy braking whenever possible.

Fuel and engine oil consumption may be higher during the break-in phase. You may notice some smoke during the first few drives because of wax and oil evaporating off the exhaust system. If so, simply park in an outdoor space.

## TURNING ELECTRICAL POWER ON WITHOUT STARTING THE ENGINE

- > Insert the key into the ignition switch.
- > Turn the key to the ACC position (2) to switch on electrical accessories without starting the engine.

Drawing power without running the engine can discharge and deplete the battery. Make sure not to draw power in ACC mode longer than necessary.

## STARTING AND STOPPING THE ENGINE

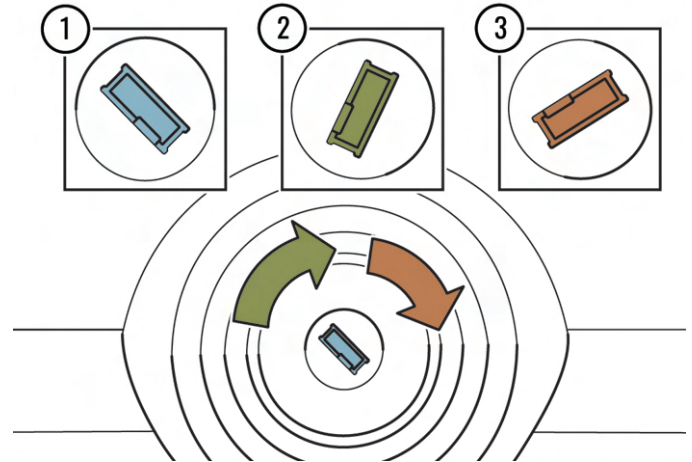

To start the engine:

- > Ensure the gear selector is in the P (Park) position. The engine will not start otherwise.
- > Press and hold the brake pedal with your foot.

## DRIVING ON ROAD

- > Insert the key into the ignition switch. It will be in the OFF position (1) in the diagram.
- > Turn the key to the START position (4).
- > Once the engine starts, release the key and allow it to turn back to the RUN position (3). Holding the key in position (4) with the engine running may damage your Grenadier.

In temperatures of -4°F (-20° C) and below, do not run the engine above 4,000 rpm, while stopped or pulling away until the coolant temperature gauge reaches normal operating temperature. If you do, your engine may be damaged.



**WARNING: Anyone with the key can start your Grenadier. Keep the key away from children. Letting children have unsupervised access to the key can allow them to deplete the battery and to start the engine. That can lead to disablement, rollaways, carbon monoxide poisoning, and other such dangers. Children can also ingest the battery, which can be fatal. Failure to follow these instructions and precautions may result in serious injury and death.**

### Turning the engine off

To turn off the engine:

- > Bring your Grenadier to a full stop and continue to press the brake pedal with your foot.
- > Set the parking brake.

- > Shift the gear selector to the P (Park) position.
- > Turn the key to the OFF position (1).

### PARKING BRAKE

You should set the parking brake whenever you park. You must set the parking brake when:

- > Parking on a slope.
- > Loading and unloading your Grenadier.
- > Jacking your Grenadier.
- > Changing a tire.
- > Attaching or detaching a trailer.
- > Parking with an attached trailer.

To set the parking brake:

- > Bring your Grenadier to a complete stop with the brake pedal. Do not brake your Grenadier with the parking brake.
- > Firmly press and hold the brake pedal with your foot.
- > Without pressing the button on the end of the parking brake lever, pull the lever up firmly, applying as much pulling force as needed to get the brake to lock your Grenadier into place. (On steep slopes and with heavy loads, more braking force may be needed and you may have to pull harder.)

# DRIVING ON ROAD

- > Shift the gear selector to the P (Park) position.
- > Release the brake pedal.
- > Make sure that your Grenadier is held in position.

To release the parking brake (when it is safe to do so):

- > Firmly press and hold the brake pedal with your foot.
- > Press the button at the end of the parking brake lever while pulling the lever up slightly.
- > While continuing to hold the button at the end of the parking brake lever, lower the parking brake lever completely.
- > Make sure the parking brake lever is fully released and completely lowered before driving. If the parking brake lever is not completely lowered, this could cause the rear brakes to overheat and become damaged.



**WARNING: Failure to follow these instructions and precautions may result in serious injury and death.**

## POWERTRAIN

Your Grenadier is equipped with an eight-speed automatic transmission (gearbox) complemented by a two-speed transfer case. This combination results in eighteen gear options: sixteen forward and two reverse.

The Grenadier is a full-time four-wheel-drive vehicle. Whether on road or off, power is continuously distributed to both front and rear axles through the transfer case and a center differential.

The Grenadier's transmission is in automatic mode by default. You can switch over to manual shifting.

## TRANSMISSION CONTROLS

### Gear Selector

The gear selector is on the console to the right of the driver seat. It allows the driver to shift the transmission between the following modes:

1	<b>R</b>	Reverse	Transmits power to the wheels in the reverse direction.
2	<b>N</b>	Neutral	Disconnects power to the wheels, allowing you to shift the transfer case between high and low range when stationary.
3	<b>D</b>	Drive	Transmits power to the wheels in the forward direction.
4	<b>M</b>	Manual	The 8-speed transmission gear is selected by the driver.
5	<b>P</b>	Park	Locks the transmission so power is not transmitted to the wheels.

## DRIVING ON ROAD

The selected mode is signaled by lights on the gear selector handle and on the Center Display and Touchscreen.

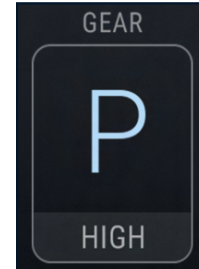
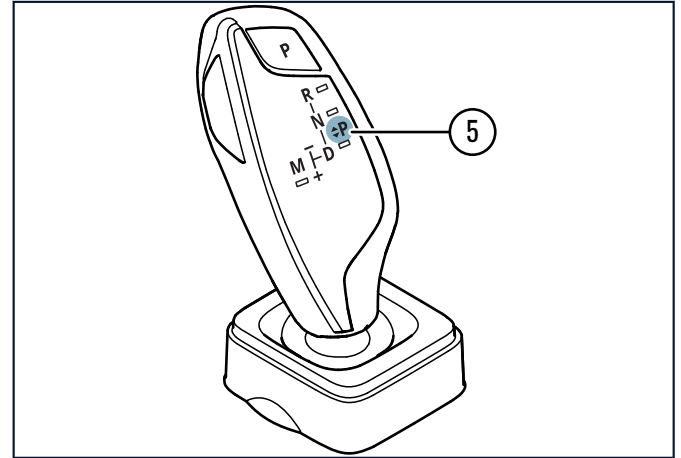
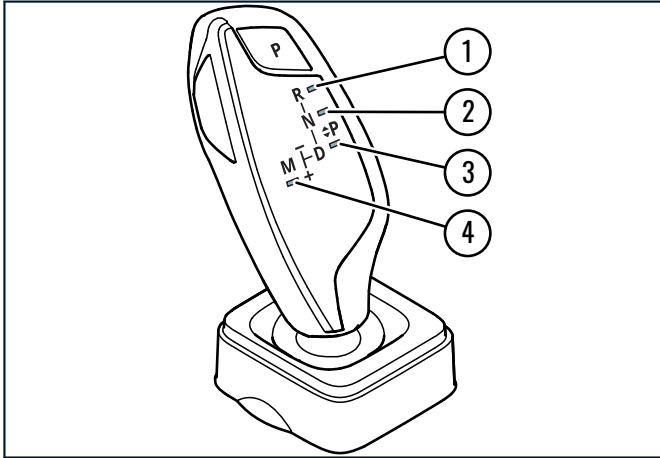



## DRIVING ON ROAD

Your Grenadier is automatically in P (Park) when:

- > The driver seat belt is unbuckled and the driver's door is not latched.
- > The engine is switched off with the transmission in D (Drive) or R (Reverse).

### To operate the gear selector:

- > Make sure the driver seat belt is buckled; this is required to shift from P (Park).
- > If shifting into or out of P (Park), R (Reverse), or D (Drive) press the brake pedal and make sure your Grenadier is stopped.
- > Press and hold the gear selector release button on the left side of the selector handle.

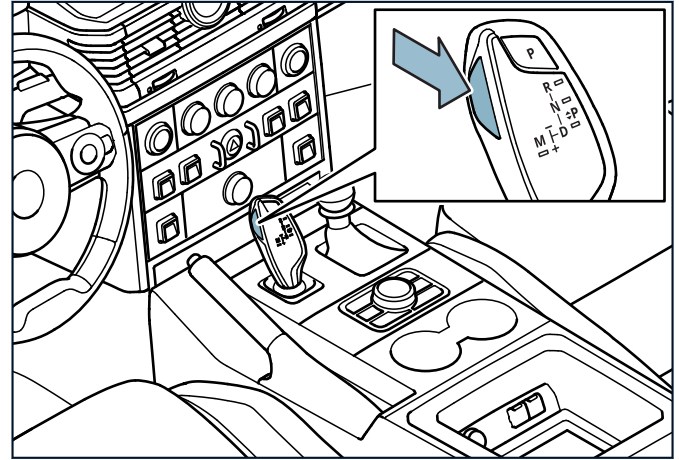

- > Move the gear selector to the desired position and release the button.

## DRIVING ON ROAD

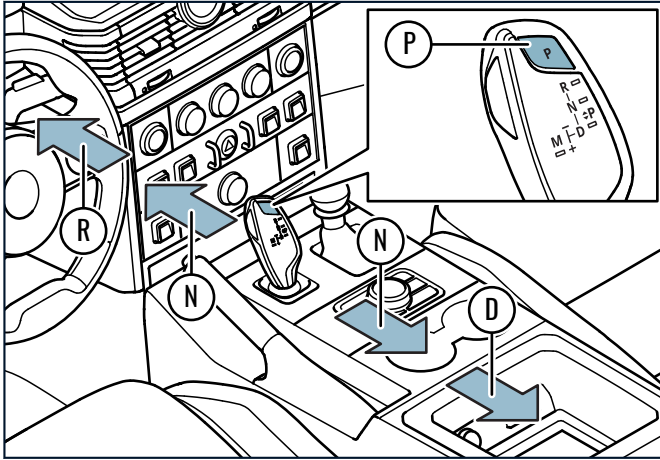

**WARNING:** N (Neutral) is not for towing your Grenadier significant distances. Do not push or roll your Grenadier in N (Neutral) more than required to avoid damage to your Grenadier's drivetrain. See the Transporting Your Grenadier section for specific recommendations.

### Manual Shifting Mode

Manual shifting mode can be useful in different situations, including:

- > On steep descents, when downshifting can provide engine braking to help to control your speed without over-relying

on the brakes. This can reduce brake overheating and wear.

- > On steep ascents, when a lower gear can provide more power.
- > When towing heavy loads, and a lower gear can provide additional torque to help move the weight, especially from a standstill or up an incline.

To activate manual mode:

- > Move the gear lever to the left from the D (Drive) position.

## DRIVING ON ROAD

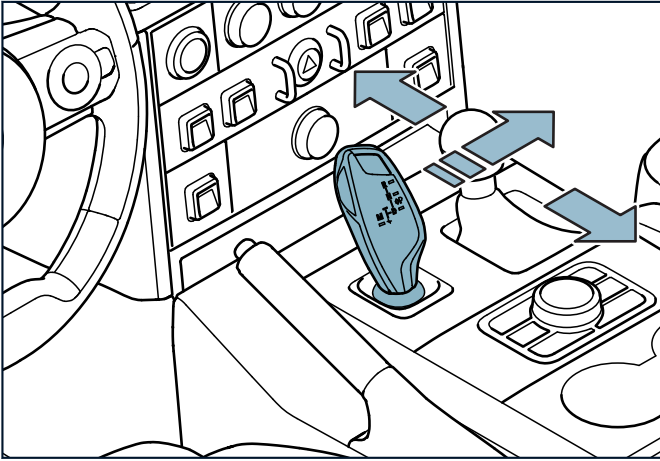

- > Use the gear selector to manually change gears.
- > To shift down, press the gear selector forward.
- > To shift up, pull the gear selector rearward.

A dot appears to the right of the M (Manual) mode on the Central Display, and the gear (1 through 8) is indicated to the left.

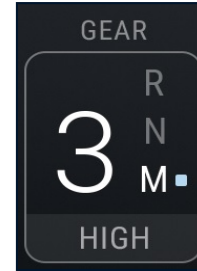

A visual signal may recommend shifting to a more optimal gear for fuel consumption. The signal appears above the display of the currently selected gear. The example below recommends that the driver shift up from 3rd gear to 5th.

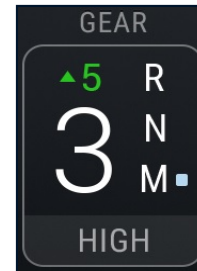

## DRIVING ON ROAD

---

While in M (Manual) mode, the transmission may still shift automatically to reduce the risk engine damage from forcing too low or high a gear. Avoid selecting a gear that causes the engine to reach excessive engine speeds or frequently reach the engine speed threshold. It can lead to overheating and component damage.

To return to automatic shifting mode:

- > Move the gear selector to the right to the D (Drive) position.

### Transfer Case Selector

The two-speed transfer case allows you to shift between high range and low range. High range is for normal, everyday driving. Low range can be useful when increased wheel torque is needed at low speeds in off-road conditions.

Leave the transfer case selector in High and unlocked whenever driving on paved roads. See Driving Off Road for details about the other options.

### Eco Start/Stop

Eco Start/Stop temporarily switches off the engine for a time when your Grenadier has been stopped by brake pedal application, such as when stopped at traffic lights or in stopped traffic.

The Eco Start/Stop function is on by default when your Grenadier is started. It can be manually switched off by pressing the Start/Stop

 button on the Center Console.

Eco Start/Stop will restart the engine when:

- > The driver's seat belt is unbuckled and the driver's door is opened.
- > The gear selector is moved to position N (Neutral), R (Reverse), D (Drive), or M (Manual).
- > The accelerator pedal is pressed.
- > The Start/Stop button is pressed.
- > The climate controls are adjusted.
- > Your Grenadier is allowed to roll.

After Eco Start/Stop activates, and if you expect to be stopped for a long period of time, you can shift the gear selector to the P (Park) position and release the brake pedal. When you are ready to move your Grenadier again, press the brake pedal and shift to D (Drive) and the engine will automatically restart.

Eco Start/Stop will not activate when:

- > The battery charge is below 50%.
- > Your Grenadier is on a steep slope.
- > The brake pedal is not adequately pressed.
- > The driver's seat belt is unbuckled, and the driver's door is not fully closed.
- > The hood is not fully latched.
- > The engine, transmission, or battery are cold.

# DRIVING ON ROAD

---

- > The transfer case is in LOW range.
- > Off-road Mode or Wading Mode is active.
- > The outside temperature is too low or high.
- > A trailer is connected to the towing electrics socket.

## REVERSE CAMERA

The Center Display and Touchscreen will automatically change to show a rear-view image when the gear selector is moved to R (Reverse).

The wide-angle Rear-View Camera gives an added view to the rear when in reverse. However, it is not a substitute for turning around, using the mirrors, and looking to the side before operating in reverse or backing the vehicle.

Your Grenadier is not equipped with a feature that senses and responds to cross traffic in the rear (vehicles, pedestrians, cyclists, and object approaching your Grenadier from the side).

## TIRES AND WHEELS WHILE DRIVING

### Introduction

As mentioned in the Before Driving section, tires are very important. Wheels are important because they hold the tires.

### Inspections, maintenance, and vigilance

You must maintain recommended tire pressures, making sure they are correct notwithstanding load, temperature, and other conditions that can affect tire pressure.

You can find the recommended tire pressure inside the fuel door and in the 'Maintenance Repairs and Technical Information' chapter of this manual.

Driving with tires under inflated or overinflated adversely affects vehicle handling. That can lead to loss of control, serious injury, and death.

You are responsible for visually inspecting your tires and wheels before driving and after stopping on a journey. Check the tires every two weeks, as well as before and after any off-road adventures or driving through water. You must remedy any tire or wheel condition that could lead to poor performance or disablement.

You must be alert and responsive to signals from your Grenadier (e.g. slow steering response, softness in the ride, jittery steering response, strange sounds, strange vibrations) indicative of a problem with a tire or wheel.

Your Grenadier has a Tire Pressure Monitoring System (discussed below). It is not a substitute for inspections, maintenance, and vigilance.

Tires are damaged if driven when substantially under-inflated. That could lead to delamination (loss of the tread ply), bursting, or sudden air loss. Those can lead to loss of control, serious injury, and death.

# DRIVING ON ROAD

Do not drive your Grenadier if the tire is damaged (e.g., cut, cracked, bulging). Driving with a damaged tire can result in a sudden disablement and a crash.

Replace your tires when the tread gets low. Do not wait for a failed state inspection. The lower your tire tread, the greater the risk of losing traction. That risk is especially great on wet (where you may hydroplane) and snowy roads.



**WARNING:** Failure to follow these instructions and precautions could lead to a loss of control and to serious injury and death.

## Tire Pressure Display

You can see real-time tire information on the Center Display and Touchscreen. Select the OFFROAD tab, then the TEMPERATURE display to see:

- > Tire position.
- > Tire pressure.
- > Tire temperature.



## Tire Pressure Monitoring System (TPMS)



*NOTE: This device complies with Part 15 of the FCC Rules . Operation is subject to the following two conditions: (1) This device may not cause harmful interference, and (2) This device must accept any interference received, including interference that may cause undesired operation.*



*NOTE: Changes or modifications not expressly approved by the party responsible for compliance could void the user`s authority to operate the equipment.*

Each tire, including the spare (if provided), should be checked monthly when cold and inflated to the inflation pressure recommended by the vehicle manufacturer on the vehicle placard or tire inflation pressure label. (If your vehicle has tires of a different size

## DRIVING ON ROAD

than the size indicated on the vehicle placard or tire inflation pressure label, you should determine the proper tire inflation pressure for those tires.)

As an added safety feature, your vehicle has been equipped with a tire pressure monitoring system (TPMS) that illuminates a low tire pressure telltale when one or more of your tires is significantly under-inflated. Accordingly, when the low tire pressure telltale illuminates, you should stop and check your tires as soon as possible, and inflate them to the proper pressure. Driving on a significantly under-inflated tire causes the tire to overheat and can lead to tire failure. Under-inflation also reduces fuel efficiency and tire tread life, and may affect the vehicle's handling and stopping ability.



***NOTE: TPMS is not a substitute for proper tire maintenance, and it is the driver's responsibility to maintain correct tire pressure, even if under-inflation has not reached the level to trigger illumination of the TPMS low tire pressure telltale.***

Your vehicle has also been equipped with a TPMS malfunction indicator to indicate when the system is not operating properly. The TPMS malfunction indicator is combined with the low tire pressure telltale. When the system detects a low pressure, the telltale will flash for approximately one minute and then remain continuously illuminated. When the system detects a high pressure or an error, the telltale will remain continuously illuminated. This sequence will continue upon subsequent vehicle start-ups as long as the malfunction exists. When the malfunction indicator is illuminated, the system may not be able to detect or signal low tire pressure as intended. TPMS malfunctions may occur for a variety of reasons,

including the installation of replacement or alternate tires or wheels on the vehicle that prevent the TPMS from functioning properly. Always check the TPMS malfunction telltale after replacing one or more tires or wheels on your vehicle to ensure that the replacement or alternate tires and wheels allow the TPMS to continue to function properly.

The Tire Pressure Monitoring System (TPMS) actively monitors your tire pressures and temperatures when you're driving. If the pressure rises or falls beyond defined parameters, the system will warn you.

Each time you drive a bit after starting your Grenadier, the TPMS

does a quick self-check. You'll see a tire pressure warning light  in the telltale cluster. If everything's okay, the light goes off. If it stays on, there's an issue. Adjust the tire pressure to the recommended level. If the light remains on consult your INEOS dealer.

In certain off-road driving scenarios, you might want to reduce your tire pressure to improve performance e.g. Traction. You can reset the TPMS in the SETTINGS tab of your Grenadier on the Center Display and Touchscreen. If you do reduce your tire pressure, always re-inflate your tires to their regular pressure when you return to the public roads.

The following table displays the warning information that may be visible or heard, when triggered.

## DRIVING ON ROAD

FAULT	WARNING	TELLTALE	AUDIBLE
Tire pressure leakage	Stop your Grenadier, fast leakage detected	YES	YES
Tire pressure low	Tire pressure is too low, please check	YES	YES
Tire pressure high	Tire pressure is too high, please check	YES	YES
Tire temperature high	Tire temperature is too high, please check	YES	YES
System malfunction	Contact an INEOS dealer to check TPMS	YES	NO
Tire pressure sensor lost	Contact an INEOS dealer to check sensor	YES	NO
Sensor battery low	Contact an INEOS dealer to check sensor	YES	NO

Secure the damaged wheel low in the cargo area; do not replace it on the spare wheel storage. Secure the damaged tire so it will not

move while in transit. Failure to properly secure the damaged tire can result in serious injury and death.

### Tire emergencies while driving

If you have a tire or wheel problem on the road, it is important to be extra careful.

If you have a tire disablement (e.g., delamination, tread separation, blowout, air loss) while driving, do not overreact. Loss of a tire reduces handling capacity.

- > Hold the steering wheel firmly and steadily.
- > Take your foot off the accelerator pedal and allow your Grenadier to slow down.
- > If you must brake, do so gently.
- > Carefully and gradually pull off of the travel lanes and stop.
- > Activate the hazard lights (yourself or with a passenger's assistance) as soon as it is possible to do so safely during this process.
- > Pull as far off of the travel lanes as possible. Stop in a place that is as far away from traffic—particularly high-speed traffic—as possible. Be sure that your Grenadier is visible to anyone who may approach.
- > Place warning signs or flares if possible. Do not use flares when there is a risk of catching surroundings on fire.



## DRIVING ON ROAD

- > Bear in mind that the taillights and hazard lights on the back of your Grenadier are obscured by an open rear door. Do not keep rear doors open any longer than necessary.



**WARNING: Failure to follow these instructions and precautions could result in serious injury and death.**

### DRIVER SUPPORT SYSTEMS



#### WARNING:

- > Driver support systems are not designed to allow the driver a pause in concentration or to replace the driver's attention under any circumstance. The driver accepts full responsibility when driving your Grenadier.
- > Engaging the rear and/or front differentials disables ESC. Exercise caution

### Cruise Control

Cruise control is a system that automatically maintains a vehicle's set speed without requiring the driver to press the accelerator. Your Grenadier's system is not a so-called "Smart" or "Adaptive" system. It cannot detect a vehicle ahead and slow accordingly, it is up to the driver to maintain a safe following distance.

Use the steering wheel buttons to manage the Cruise Control feature:



Tap the Cruise Control button  to set the system to standby. A grey Cruise Control icon will appear on the Center Display and Touchscreen.

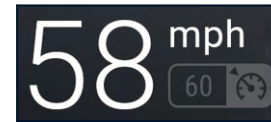

While traveling at a speed greater than 19 mph (30 km/h), tap the SET- button to engage Cruise Control at your current speed. Upon activation, the icon turns green, displaying the set speed.



Tap RES+ to raise or SET- to reduce the set speed. Holding either button prompts larger set speed changes.

Avoid using Cruise Control:



In heavy traffic.



When traffic is not moving along at or near the speed limit.



On twisting routes that necessitate frequent speed shifts.

# DRIVING ON ROAD

- > On uneven or slippery surfaces (e.g., heavy rain, standing water, snow, ice, gravel, sand, mud).
- > During avoidance maneuvers.
- > When visibility is reduced e.g., fog, downpours, snow).

To return the Cruise Control to standby, tap the CNL button or press the brake pedal. The previously set speed will be stored.

Tap RES+ to resume the last set speed, or SET- to reset with a new set speed.

## Anti-Lock Brake System (ABS)

The Anti-lock Braking System (ABS) senses when one or more wheels is locking during heavy braking. ABS modulates pressure to individual brakes to attempt to prevent wheel lockup. It can reduce the risk of sliding, spinning, skidding.

When it is activated, you will hear a sound like driving over rumble strips, and you may feel shuddering. That is the brake system activating automatically.

ABS does not shorten stopping distance. It does not increase braking power when carrying heavy loads or towing. Do not assume that ABS will make it safe to tailgate. It won't.

If the front or rear differential is locked, ABS is automatically disabled and the  telltale turns on. ESC is also disabled.



**WARNING: Failure to follow these instructions and precautions could result in serious injury and death.**

## Traction Control

Traction control senses when a wheel is slipping during acceleration. It can reduce torque to a wheel to reduce the risk of such slipping.

## Electronic Stability Control (ESC)

Electronic Stability Control (ESC) reduces the risk of plowing out or spinning out during turns. ESC uses sensors to detect if your Grenadier is plowing or skidding, and will apply brakes to specific wheels and adjust engine output to attempt to reduce plowing or skidding. ESC is particularly useful in slippery conditions.

ESC does not increase the amount of available friction. It cannot change the laws of physics. If you drive too fast for the road conditions, or drive on slippery surfaces, there may not be enough tire/surface friction to allow you or ESC to generate enough effective braking force. Low tire tread also impairs ESC effectiveness. Do not assume that ESC will allow you to drive at normal speeds in abnormal conditions. It won't.

ESC is not intended to allow adventures in dangerous conditions. It is intended to reduce the risk of plowing and skidding when the driver has made a mistake.

When ESC is triggered and engaged, the ESC telltale lamp  will blink.

The main reason to turn ESC off is to prevent traction control cutting power to the wheels on certain surfaces (e.g., in sand). To turn ESC

# DRIVING ON ROAD



off, press and hold the ESC OFF  button on the Overhead Control

Panel until the telltale lamp  is illuminated and the Center Display and Touchscreen shows the message "ESC OFF".

ESC is turned off automatically in Off-Road and Wading Modes and when a differential is locked.

Whenever ESC is off, ABS is off too.

ESC automatically turns on whenever the engine is turned on. ESC also automatically turns back on if your Grenadier is driven faster than 48 mph (78 km/h) . ESC cannot be deactivated above this speed.

To re-activate ESC, press and hold the ESC button  until the ESC OFF telltale lamp  turns off.



**WARNING: Failure to follow these instructions and precautions could result in serious injury and death.**

## Parking aid systems

Your Grenadier is equipped with systems that use ultrasonic sensors on the rear bumper and, if equipped, the front bumper to help in parking.

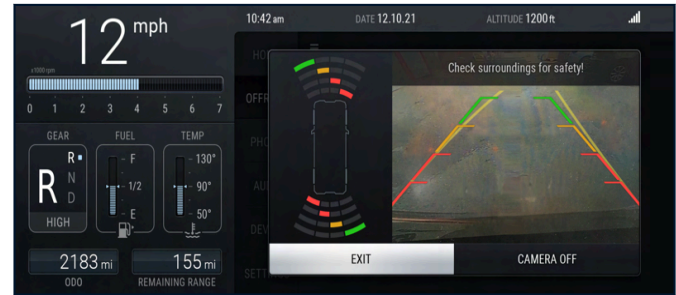

Parking Assist Rear sends sound and visual signals when you are backing close to an object at 10 mph (15 km/h) or less while moving backward.

Parking Assist Front (if equipped) sends sound and visual signals when you are coming close to an object at 10 mph (15 km/h) or less while moving forward. PDC will shut off on its own if your Grenadier is driven forward for more than 164 ft. (50 m.) even at those low speeds.

These systems do not work in Off-Road Mode or Wading Mode.

## DRIVING ON ROAD

You can manually turn off the park aid systems by pressing the button  located in the bottom right of the Center Console.

If your Grenadier is equipped with the Parking Assist Front feature, you can manually disable it through the SETTINGS tab on the Center Display and Touchscreen.

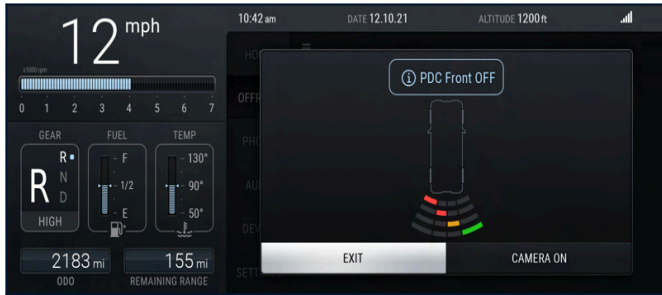

### ADVANCE DRIVER ASSISTANCE SYSTEMS (ADAS)

#### Introduction

Your Grenadier is equipped with four Advanced Driver Assistance Systems (ADAS): Intelligent Speed Assist (ISA), Driver Drowsiness Warning (DDW), Lane Departure Warning (LDW) and Forward Collision Warning/Automatic Emergency Braking (FCW/AEB). ISA, LDW and FCW/AEB use information gathered from a camera mounted on

the upper windshield to assist the driver in reducing the risk of collision in certain situations.

These systems are disabled if you enter Off-Road Mode or Wading Mode.

Each ADAS function is automatically activated whenever your Grenadier's ignition is turned on. You may deactivate one or all of these functions for the drive cycle by pressing Settings then Vehicle Functions, then ADAS on the Center Display and Touchscreen. You may then select which ADAS function you wish to deactivate.

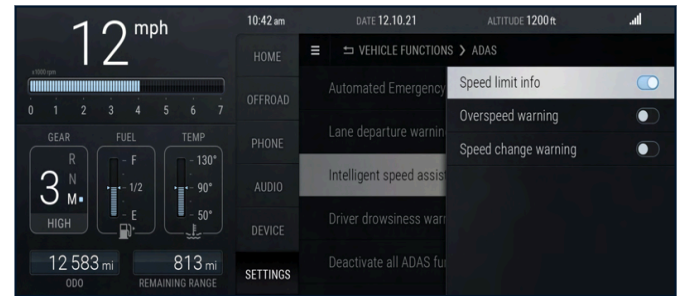

# DRIVING ON ROAD

You must touch Confirm to complete the deactivation.



Each ADAS function will reactivate when your Grenadier's ignition is next turned on. You cannot permanently disable any ADAS.

Each ADAS self-diagnoses while in operation. If it detects a system malfunction, then it will send a visual signal on the Telltale Cluster and the Center Display and Touchscreen.



**WARNING:** These are driver assistance systems. They are not driver substitutes. There are limits to what they can do, as described below. Do not rely on any of them to prevent collisions. The driver remains solely responsible for the safe operation of your Grenadier. Failure of the driver to give full attention to driving may result in a collision and in serious injury or death.



**WARNING:** Do not assume that your Grenadier has systems that may be on other vehicles you have used. It has only the four ADAS described below. Assuming that the Grenadier has systems that it does not have may contribute to a collision and to serious injury or death.



**NOTE:** Anything that obscures or impedes the view of the front camera can impede one or more ADAS functions. Keep the windshield in front of the camera clean and clear. If the front camera is obscured, ADAS will send an audio and visual signal.

# DRIVING ON ROAD

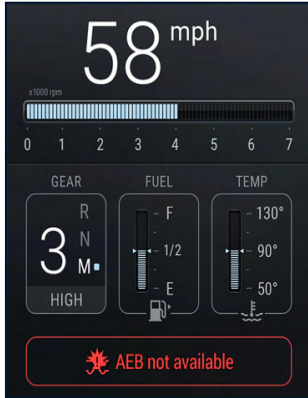

## Intelligent Speed Assist (ISA) Overview

Intelligent Speed Assist (ISA) uses the front camera and information from your Grenadier's GPS software to detect the speed limit. ISA displays that information to the driver via the Center Display and Touchscreen. ISA sends an audio signal and updates the icon on the Center Display and Touchscreen when ISA detects a change in the posted speed limit.

ISA sends an audio signal and flashes the speed limit sign on the Center Display and Touchscreen when the driver exceeds the posted speed limit. ISA will continue flashing the speed limit icon until the driver reduces speed to or below the limit. The audio signal ends after three seconds.



*NOTE: The ISA audible warning can be toggled off at the user's discretion. Once turned off, it will remain in the chosen state and will not automatically reactivate with each ignition cycle.*

# DRIVING ON ROAD

## ISA Operation

ISA uses the front camera to detect speed limit signs.



ISA can also detect electronic signs that are overhead or to the side of the road. ISA uses the map software in your Grenadier to recognize the country in which your Grenadier is being driven and for additional information about the speed limit. If there is a conflict between the signs that the front camera detects and your Grenadier's map software, ISA will rely on what the camera detects.

ISA is not synchronized with phone-based mapping apps (e.g., Waze, Google Maps, Apple Maps), even if those are being displayed on the Center Display and Touchscreen.

ISA does not recognize speed limits that are painted on the pavement.

Some jurisdictions post general application signs to the effect that the maximum speed limit is x unless otherwise posted. ISA does not detect or react to such signs.

ISA does not detect or react to conditional limits, such as those that reduce speed limits during certain times (e.g., school hours) and those that require lower speeds when children are present.

ISA can take up to one second to signal a detected speed limit.

ISA cannot detect speed limits that are not posted on detectable signs or on private roads. In that event, a video signal "ISA Limited" will appear on the Center Display and Touchscreen.



**WARNING: The driver is responsible for detecting and heeding speed limits. Failure of the driver to do so may result in serious injury or death.**

## Driver Drowsiness Warning (DDW) Overview

Driver Drowsiness Warning (DDW) monitors certain parameters of driver behavior (such as steering frequency, and operation of controls). It compares the driver's measured behavior to expectations of an attentive driver. If DDW calculates that the driver's measured behavior indicates drowsiness or inattention, it sends an

# DRIVING ON ROAD

---

audio signal and a visual signal on the Center Display and Touchscreen to recommend the driver to take action.



## DDW Operation

DDW does not operate at lower speeds. It initializes and can send signals after the driver first reaches a speed of about 43 mph (70 km/h) in that ignition cycle. DDW then operates normally at speeds from about 40 to 81 mph (65 to 130 km/h). DDW's ability to interpret driver behavior degrades the faster you drive over 81 mph (130 km/h).

DDW is automatically activated each time your Grenadier ignition is turned on.



# DRIVING ON ROAD



## WARNING:

- > The driver is responsible for remaining alert and attentive. Failure of the driver to do so may result in serious injury or death.

## Lane Departure Warning (LDW) Overview

Lane Departure Warning (LDW) uses the front camera to detect lane markings. It sends audio and visual signals when it detects that the driver has allowed the outer edge of a tire to get within a few inches of a lane marking or road edge without signaling a lane change.

When LDW is activated, lane markings appear in grey.

When a lane marking is detected that lane icon turns green.



## DRIVING ON ROAD

The lane marking that is being approached turns orange on the central display.



### LDW Operation

LDW is automatically activated each time your Grenadier ignition is turned on.

LDW does not signal:

- > When a turn signal is on.
- > When the hazard lights are on.
- > At speeds lower than about 40 mph (65 km/h) .

LDW does not operate:

- > When your Grenadier is being driven through sharp curves.
- > During hard accelerating (over about 70% throttle).
- > During hard braking.
- > During hard steering.
- > During ESC operation.
- > When the driver actively steers toward the lane boundary.
- > In very narrow lanes.

LDW may not recognize:

- > Lane markings or road edges that are faded, hard to see or obscured (e.g., by dirt, snow or standing water).
- > Irregular or confusing lane markings (e.g., construction zones) or unusually spaced (e.g., toll plazas).



**WARNING: The driver is responsible for remaining within the travel lane. Failure of the driver to do so may result in serious injury or death.**

### Forward Collision Warning (FCW) & Automatic Emergency Braking (AEB) Overview

Forward Collision Warning (FCW) and Automatic Emergency Braking (AEB) use the front camera to detect when certain frontal collisions are imminent. FCW can send a sound and a visual signal to warn the driver. It sends them about 2 seconds before the collision is

## DRIVING ON ROAD

predicted to occur (absent an evasive maneuver by the driver). AEB can automatically apply the brakes to reduce the speed of an impact. It applies the brakes about 0.9 seconds before the collision is predicted to occur (absent an evasive maneuver by the driver).



Neither system can prevent every collision on its own. FCW simply sends warnings; it does not brake or steer. AEB applies brakes, but cannot reduce speed by a maximum of about 37 mph (60 km/h) on dry pavement. Its ability to slow your Grenadier is reduced if surface friction or tire friction are reduced. AEB can only reduce speed; it cannot prevent all collisions.

### FCW & AEB Operation

FCW & AEB are automatically activated each time your Grenadier ignition is turned on.

FCW & AEB operate normally at speeds from about 6 to 81 mph (10 to 130 km/h) . The system does not operate at higher speeds.

FCW & AEB use the front camera to detect certain other road users in your lane of travel. Anything that would impede a human's ability to see (e.g., darkness, nighttime, fog, mist, snow, heavy rain, spray, glare, bright direct light, low light, when the sun is low) can impair the camera's effectiveness. Anything on the windshield that obscures the camera's view (e.g., dirt, stickers, tint, condensation, ice, windshield damage, objects on the hood) will impede FCW & AEB's ability to detect lanes and other road users. When your Grenadier is angled up or down on a steep slope, is turned sharply to one side, or is in a tight turn (< 600ft/180m curve radius) , the camera's angle will also change so as to change its field of view.

If your windshield is replaced, be sure to use a genuine INEOS replacement windshield or its equivalent, and be sure that the repair shop remounts the camera properly. Errors in replacing windshields can degrade FCW & AEB operation.

FCW & AEB use the front camera to detect lanes by recognizing lane markings. Anything that impedes the visibility of lanes (dirt, snow, water, hills, grades, sharp curves) or of the road users in those lanes (e.g., fog, snow, heavy rain, hills, grades, sharp curves) will impede FCW & AEB's ability to detect lanes and other road users.

FCW & AEB are programmed to recognize only certain other road users. FCW & AEB are programmed to recognize and react to certain vehicles, specifically cars, crossovers, SUVs and trucks. FCW & AEB

## DRIVING ON ROAD

are not programmed to recognize anything else, including bicyclists, pedestrians, joggers, runners, animals, people on scooters, motorcycles, or objects in the road.

FCW & AEB cannot interpret other road users' intentions. They cannot tell whether a vehicle that is outside of your lane is about to or may enter your lane.

FCW & AEB may not recognize or respond when:

- > A vehicle blends into the background and is difficult to distinguish;
- > A vehicle has an unusual taillight configuration;
- > A vehicle has cargo protruding from its rear;
- > A vehicle is carrying cargo on top;
- > A vehicle is using a cargo carrier;
- > A vehicle is towing something;
- > A vehicle is in a roundabout;
- > A vehicle is braked or stopped abruptly;
- > Your Grenadier is moved abruptly into another lane;

The camera may not operate properly or at all when its temperature drops below about -40°F (-40°C) or exceeds about 170°F (75°C).

AEB is overridden and stops operating when the driver intervenes with hard steering or acceleration.

AEB will continue braking if the driver brakes, but will disengage if the driver brakes and then releases the brake.

FCW & AEB are deactivated when ESC is turned off and when the differentials are locked.



**WARNING: The driver is responsible for detecting and avoiding objects and other road users. Failure of the driver to do so may result in serious injury or death.**

Never purposefully trigger FCW or AEB. Doing so risks a collision which may cause serious injury or death.

### FCW & AEB Operation

FCW & AEB are automatically activated each time your Grenadier ignition is turned on.

FCW & AEB operate normally at speeds from about 6 to 81 mph (10 to 130 km/h). The system does not operate at higher speeds.

FCW & AEB use the front camera to detect certain other road users in your lane of travel. Anything that would impede a human's ability to see (e.g., darkness, nighttime, fog, mist, snow, heavy rain, spray, glare, bright direct light, low light, when the sun is low) can impair the camera's effectiveness. Anything on the windshield that obscures the camera's view (e.g., dirt, stickers, tint, condensation, ice, windshield damage, objects on the hood) will impede FCW & AEB's ability to detect lanes and other road users. When your Grenadier is angled up or down on a steep slope, is turned sharply to one side, or is in a tight turn (< 600ft/180m curve radius), the camera's angle will also change so as to change its field of view.

If your windshield is replaced, be sure to use a genuine INEOS replacement windshield or its equivalent, and be sure that the repair

## DRIVING ON ROAD

---

shop remounts the camera properly. Errors in replacing windshields can degrade FCW & AEB operation.

FCW & AEB use the front camera to detect lanes by recognizing lane markings. Anything that impedes the visibility of lanes (dirt, snow, water, hills, grades, sharp curves) or of the road users in those lanes (e.g., fog, snow, heavy rain, hills, grades, sharp curves) will impede FCW & AEB's ability to detect lanes and other road users.

FCW & AEB are programmed to recognize only certain other road users. FCW & AEB are programmed to recognize and react to certain vehicles, specifically cars, crossovers, SUVs and trucks. FCW & AEB are not programmed to recognize anything else, including bicyclists, pedestrians, joggers, runners, animals, people on scooters, motorcycles, or objects in the road.

FCW & AEB cannot interpret other road users' intentions. They cannot tell whether a vehicle that is outside of your lane is about to or may enter your lane.

FCW & AEB may not recognize or respond when:

- > A vehicle blends into the background and is difficult to distinguish;
- > A vehicle has an unusual taillight configuration;
- > A vehicle has cargo protruding from its rear;
- > A vehicle is carrying cargo on top;
- > A vehicle is using a cargo carrier;
- > A vehicle is towing something;
- > A vehicle is in a roundabout;

- > A vehicle is braked or stopped abruptly;
- > Your Grenadier is moved abruptly into another lane;

The camera may not operate properly or at all when its temperature drops below about -40°F (-40°C) or exceeds about 170°F (75°C).

AEB is overridden and stops operating when the driver intervenes with hard steering or acceleration.

AEB will continue braking if the driver brakes, but will disengage if the driver brakes and then releases the brake.

FCW & AEB are deactivated when ESC is turned off and when the differentials are locked.



**WARNING: The driver is responsible for detecting and avoiding objects and other road users. Failure of the driver to do so may result in serious injury or death.**

Never purposefully trigger FCW or AEB. Doing so risks a collision which may cause serious injury or death.

### WINTER DRIVING

# DRIVING ON ROAD

## Snow chains



### WARNING:

- > Only use snow chains on roads that are heavily covered in snow. Snow chains can damage the road surface and your Grenadier. Comply with local laws on the use of snow chains.
- > Heed all precautions presented previously about jacking safety. Never operate the jack on a snowy or icy surface.
- > Failure to follow these instructions and precautions may result in serious injury and death.

It is recommended that snow chains are used on all four wheels. If that is impossible or impractical, install snow chains on the rear wheels only.

Snow chains available for your Grenadier:

- > A 82 S AUSTRO-S
- > XMR 82 V BRENTA-C 4x4

Install snow chains per the snow chain manufacturer's instructions.

## Gear selection

In snowy, icy, or muddy conditions, using Manual mode and starting off in a higher gear (like second gear) can reduce wheel spin and offer better traction.

## ROADSIDE EMERGENCIES

### If you have to stop for an emergency

If you have to stop for an emergency or to check something urgently:

- > Carefully and gradually pull off of the travel lanes and stop.
- > Activate the hazard lights (yourself or with a passenger's assistance) as soon as it is possible to do so safely during this process.
- > Pull as far off of the travel lanes as possible. Stop in a place that is as far away from traffic—particularly high-speed traffic—as possible. Be sure that your Grenadier is visible to anyone who may approach.
- > Place warning signs or flares if possible. Do not use flares when there is a risk of catching surroundings on fire.
- > Bear in mind that the taillights and hazard lights on the back of your Grenadier are obscured by an open rear door. Do not keep rear doors open any longer than necessary.

## DRIVING ON ROAD



**WARNING:** Failure to follow these instructions and precautions could result in serious injury and death.

### Replacing a tire off the road

Once you have stopped safely, look around. See if the area is safe to get out. If it isn't, find a safer place. If it is, get out and determine what has happened. If you determine that you need to change a tire, make sure that your Grenadier is level and that the ground is firm and free of pebbles and rocks that could roll under your Grenadier or your jack. If the location is not suitable, find a suitable location driving as slowly and as safely as possible.

The best way to deal with a disabled tire is to replace it with your full sized spare. If that is not possible, you may be able to use a tire inflator/sealant can, but that is a poor substitute. And it can and probably will ruin your TPMS sensor in that tire.

### Retrieving the spare tire

Your Grenadier comes with a spare tire in the event of a wheel and tire being damaged.

A toolkit is included beneath the driver seat of your Grenadier.

The spare wheel is heavy and should only be taken off the stowage and wheel carrier or out from the loadbay with the help of another person.

For the Station Wagon, the spare wheel is located at the rear of the vehicle and is secured with three wheel lug nuts and a mounting ring.

To get to the spare wheel, you must first remove the Spare Wheel Cover or Spare Wheel Lockable Storage Box (if equipped).

- > If equipped, unlock the Spare Wheel Lockable Storage Box and remove it carefully.
- > Undo the three wheel lug nuts holding the spare wheel in place.
- > Slide the mounting ring off the threaded studs.
- > Remove the spare tire and wheel.

To remount a spare tire and wheel, reverse the process, torquing the three wheel lug nuts to 52 ft·lbf. (70 Nm) .

For the Quartermaster, the spare wheel is situated on the rear left side of the Load Bay, secured by a mounting plate and central bolt. To access it, you may need to remove the optional Spare Wheel Lockable Storage Box (if equipped).

- > If equipped, unlock the Spare Wheel Lockable Storage Box and remove it carefully.
- > Undo the Locking Wheel nut (if equipped) on the spare wheel mounting plate and remove the anti-theft plate.
- > Undo the central bolt holding the spare wheel in place.
- > Slide the mounting plate off
- > Remove the spare tire and wheel.

To remount a spare tire and wheel, reverse the process, ensuring the central bolt for the mounting plate is torqued to 42lb.ft (56Nm) . When remounting the spare wheel with the Locking Wheel Nut,

## DRIVING ON ROAD

torque the Locking Wheel Nut to 23lb.ft (30Nm) as per the above process.

### Jacking

There is a jack in your Grenadier for use in an emergency such as changing a tire.

In the Station Wagon, the jack is located in the cargo area behind two panels. Pull to remove the outer and inner panel to access the jack.

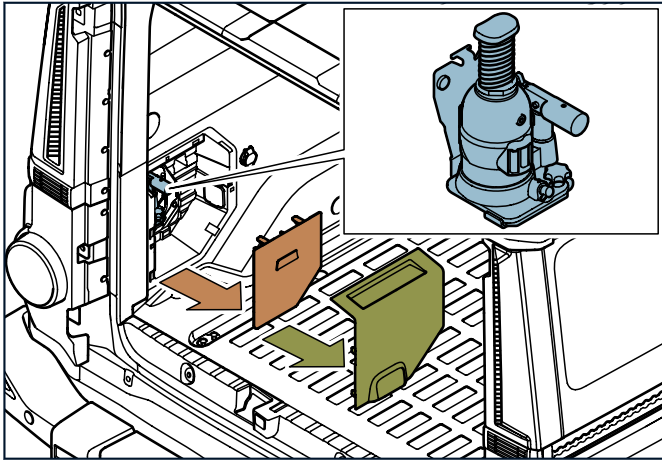

For the Quartermaster, the jack is located behind the rear bench seat.

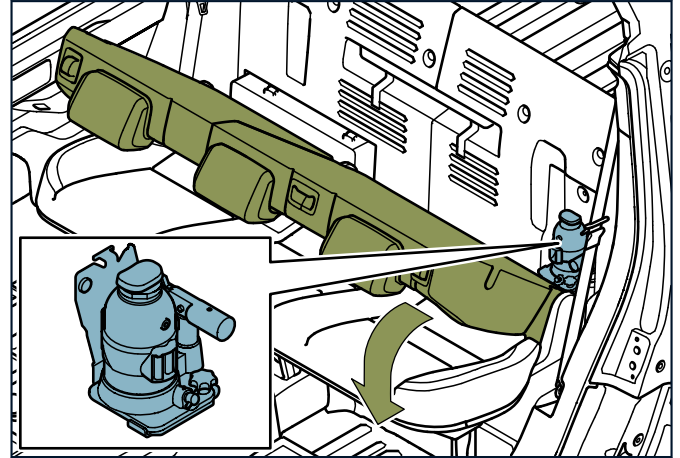



## DRIVING ON ROAD

When storing the jack, extend the center piston just enough to lock it in place.

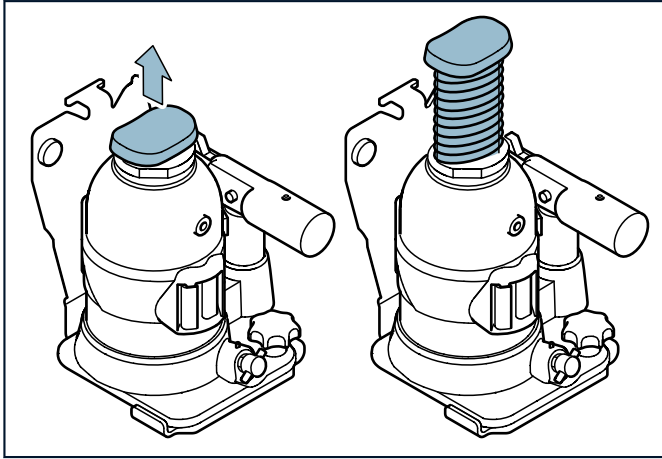

Jacking is inherently risky. You are taking a heavy vehicle that was supported by four large tires and wheels and supporting it by perhaps two wheels and a small jack. That is much less stable than leaving the Grenadier on four wheels. Also, you are exposing parts that are normally concealed.

Before jacking:

- > Allow parts under your Grenadier to cool. Some may be extremely hot.
- > Make sure to follow applicable laws. Some jurisdictions have laws governing these situations.
- > Make sure the location is safe. Park in a safe location away from traffic with the gear selector in P (Park) and the parking brake firmly set.
- > Turn on the hazard warning lamps. Setting out reflectors and wearing a high-visibility vest can help you be seen by other drivers and avoid injury. Flares can help provided they are kept well away from flammable material (e.g., gas vapor, oil, brake fluid, brush, grass, wood, trees). Do not set flares if there is any risk of catching something on fire.
- > Remove everyone from your Grenadier. Remove as much cargo as you can. Detach anything that is attached to the hitch.
- > Make sure your Grenadier, its tires, and the jack location are on solid, level ground. Clear away debris that might shift under the weight of your Grenadier. Make sure that the tires that are not to be raised are on solid ground (e.g., not mud, gravel, pebbles, sand, snow, ice). Those tires are what will you're your Grenadier from rolling with the jack.
- > Make sure that the jack is placed on solid ground (e.g., not mud, gravel, pebbles, sand, snow, ice) that is at about the same level as the tires that are not to be raised.

## DRIVING ON ROAD

- Clear the immediate area (at least 6 feet (2 meters) around the Grenadier of people and pets.
- Never allow anyone to place any body parts beneath your Grenadier while the jack is in use. Never allow anyone to enter your Grenadier while it is suspended on the jack.
- Do not allow your Grenadier to be jacked up any longer than is necessary.
- If you are changing a tire, remove the spare from the Grenadier before jacking. Removing it afterward risks toppling the Grenadier off the jack. Do not put the replaced tire into the Grenadier until it is off the jack.

To raise your Grenadier using the bottle jack:

- Follow the instructions and precautions in the previous section before proceeding.
- Close the jack release valve by turning it fully clockwise.
- Place the jack at one of the four designated jacking points on the underside of your Grenadier. Clear the ground beneath the jack of any debris that might shift when the jack takes your Grenadier's weight.

Front Axle:

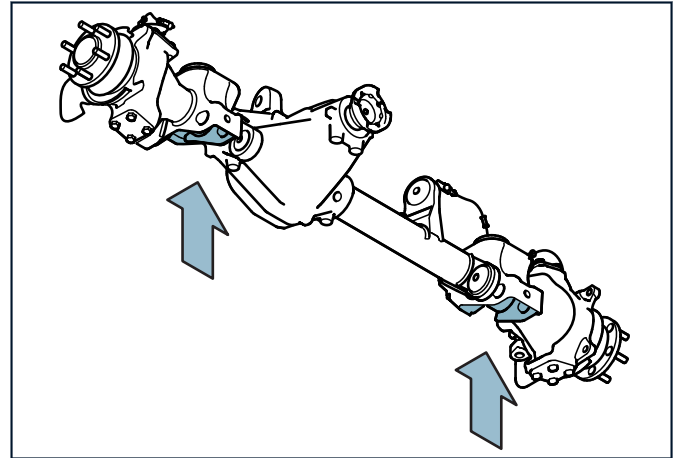

## DRIVING ON ROAD

Rear Axle:

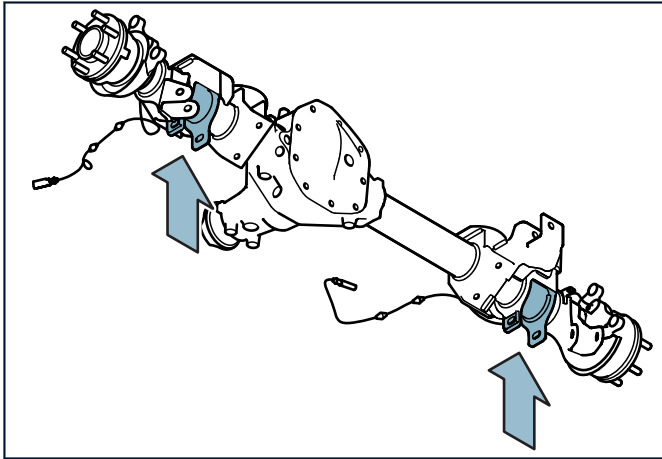

- > Pump the lever up and down to raise the jack.

To lower the jack:

- > Remove all tools and objects from beneath your Grenadier, check to make sure there are no people or parts of the body underneath your Grenadier.
- > Remove the lever from the jack and insert it into the slot on the release valve.

- > Slowly rotate the release valve, counterclockwise, to lower your Grenadier to the ground. Do this carefully to avoid sudden movements of the bottle jack and vehicle.



**WARNING:** Failure to follow these instructions and precautions could result in serious injury and death.

### Changing a Tire

To change a tire:

- > Follow all instructions and precautions discussed in the Jacking subsection.
- > Retrieve the spare tire as described previously before lifting your Grenadier.
- > Before lifting your Grenadier, loosen each of the six wheel lug nuts one full rotation. This makes it easier to remove the nuts when your Grenadier is raised.
- > Using the jack as described previously, raise your Grenadier until the tire you're changing is off the ground.
- > Completely remove the six wheel lug nuts from the damage tire. As you take off the last one, keep one hand on the wheel to prevent it from falling.
- > Carefully remove the wheel from your Grenadier.
- > Set the removed wheel aside in a safe location. Place it face-up to prevent scratches or damage.

## DRIVING ON ROAD

- > Clean the area of contact between the wheel and your Grenadier's wheel hub, removing any dirt or surface corrosion.
- > Carefully position the spare wheel onto the hub.
- > Hold the wheel steady with one hand and hand-tighten the wheel lug nuts back onto the wheel studs.
- > Lower your Grenadier carefully using the jack.
- > Tighten the wheel lug nuts in the pattern shown for even pressure. Torque each to 118 ft·lbf. (160 Nm) .

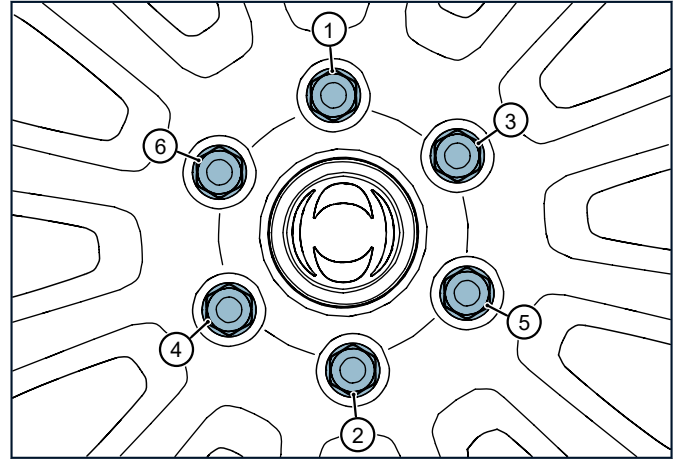

- > Replace the jack in its storage area as described previously.
- > Place the replaced tire low in the cargo area, NOT on the spare tire storage. Secure it so it will not move during transport.
- > Make sure to get a new or repaired spare as soon as possible.

The TPMS system automatically recognizes the spare tire change.

## DRIVING ON ROAD

After driving your Grenadier for about 5 minutes:

- > Re-check that the wheel lug nuts are tight.
- > Reset the TPMS in the SETTINGS tab of the Center Display and Touchscreen.

Have your Grenadier inspected by an INEOS dealer as soon as you can. It is important that lug nuts be set to proper torque.

Contact an INEOS dealer for support if the low tire pressure warning lamp  in the telltale cluster doesn't turn off or there are suspected errors with the tire pressure readings.



**WARNING: Failure to follow these instructions and precautions could result in serious injury and death.**

### Jump Starting

If you must jump start your Grenadier, the donor vehicle must have a well-charged 12-volt battery. Never jump start your Grenadier with any other voltage battery. Using a battery with a different voltage may result in an explosion.



**NOTE: Do not start your Grenadier with a quick charger.**

Although your batteries are under the rear seat, you must connect the donor battery to terminals in the engine compartment. Do not connect a positive (+) terminal to a negative (-) terminals on the battery directly. This can cause serious injury or death.

There are terminal points under the hood that must be used.

Your Grenadier's hood release lever is in the driver's footwell near the door. Pull the lever twice to release the hood. Raise the hood and secure it in place with the support rod. Familiarize yourself with the points you need before connecting anything.

There is a positive connection under a red cover. For the negative connection, use any unpainted metal part on the engine compartment housing or a non-electrical component of the engine. Do not use the fuel lines, engine rocker covers or the intake manifold as grounding points.

Make sure that there is sufficient ventilation before connecting any cables.

Make sure that the jumper cables are of sufficient gauge and that they are not worn, exposed, or damaged. Be careful not to get the cables tangled or caught on parts that will move once your Grenadier's engine is starting.

Do not disconnect the discharged battery from your Grenadier. Keep the discharged battery connected to your Grenadier. A discharged battery can freeze at 32°F (0°C) and below. Defrost the frozen battery before connecting jump leads.

To connect your vehicles:

- > Park the donor vehicle close to your Grenadier but do not let them come into direct contact.
- > Switch off all unnecessary electrical devices in your Grenadiers such as lights, radio, air conditioning, etc., to reduce the electrical load on the batteries.

## DRIVING ON ROAD

- Make sure both vehicles are in P (Park) (N (Neutral) if the donor vehicle is a manual transmission) and that their parking brakes are set.
- Turn off the donor vehicle. Open the donor vehicle's hood.
- Attach one end of the red (+) jumper cable to the positive terminal in your Grenadier's engine compartment.
- Connect the other end of the red (+) jumper cable to the positive terminal of the donor battery.
- Attach one end of the black (-) jumper cable to the negative terminal of the donor battery.
- Connect the other end of the black (-) jumper cable to the grounding point on your Grenadier.

Start the donor Vehicle:

- Check the connections are secure and in the correct positions.
- Check that the cables are not caught on any moving or mechanical parts.
- Now start the donor vehicle engine and run at about 1500-2000 rpm for two to three minutes to charge the dead battery.
- Attempt to start your Grenadier with the discharged battery. If it starts, leave both vehicles running for a few more minutes to ensure the dead battery has a chance to recharge. If it struggles to start, wait a minute or two and

try again. If there is no sign of energy in your Grenadier, check the connections.

- Do not let anyone or anything touch both vehicles at the same time. That could create a connection that could cause shock, explosion, or other harm.
- Switch the donor vehicle off.

In reverse order, disconnect the jumper cables:

- Remove the black (-) jumper cable from the previously dead vehicle's unpainted metal surface.
- Remove the other end of the black (-) jumper cable from the donor vehicle's negative terminal.
- Remove the red (+) jumper cable from the donor vehicle's positive terminal.
- Finally, remove the red (+) jumper cable from the previously dead vehicle's positive terminal.

Keep your Grenadier running while it attempts to recharge its battery.

Before the donor vehicle is driven away, and after giving your Grenadier a chance to recharge its battery, turn your Grenadier off, then try to restart it. If your Grenadier restarts, this confirms the battery is recharging when the engine is running. If not, repeat the process above but allow your Grenadier more time to recharge. Use the wait time to locate the nearest repair shop or battery seller.

Your Grenadier battery should be nearly fully recharged after 20-30 minutes.

## DRIVING ON ROAD

**i** *NOTE: If your battery repeatedly dies, have your Grenadier inspected by an INEOS dealer.*

**!** **WARNING:** Failure to follow these instructions and precautions could result in serious injury and death.

### First Aid Kit

Your Grenadier comes with a first aid kit.

For the Station Wagon the first aid kit (2) is in the rear 70 door.

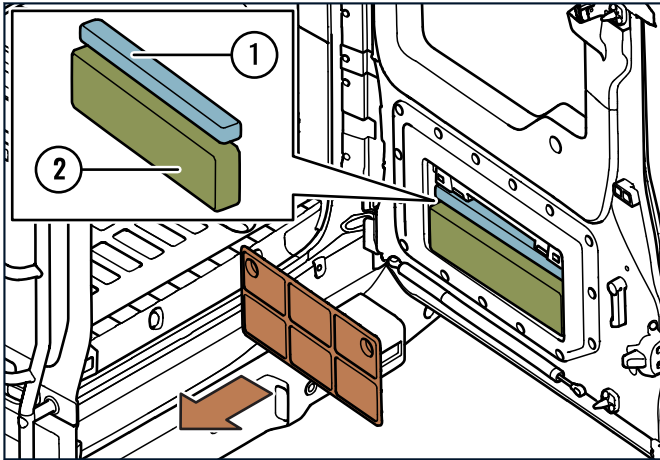

For the Quartermaster, the kit is located behind the rear bench seat.

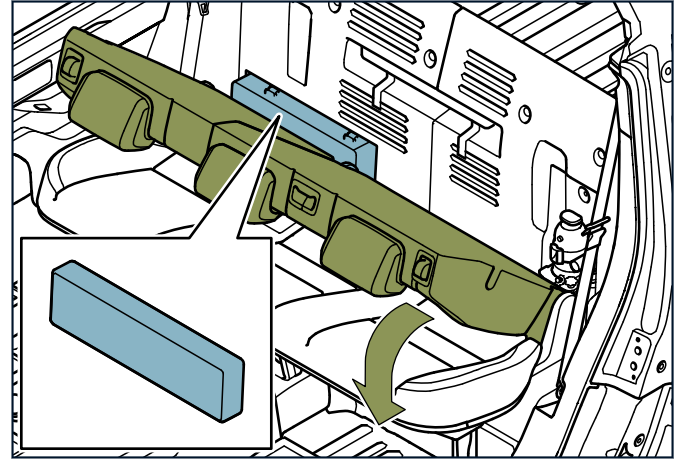

INEOS recommends you become familiar with its location and contents before it is needed.

### Warning Triangle (if equipped)

Your Grenadier may be equipped with a warning triangle. The warning triangle is used to warn other drivers of your presence on the roadside. Place the warning triangle to give other drivers time to safely adjust their speed and driving position.

## DRIVING ON ROAD

For the Station Wagon, the warning triangle (1) is located in the rear door.

For the Quartermaster, the warning triangle is located behind the rear bench seat.

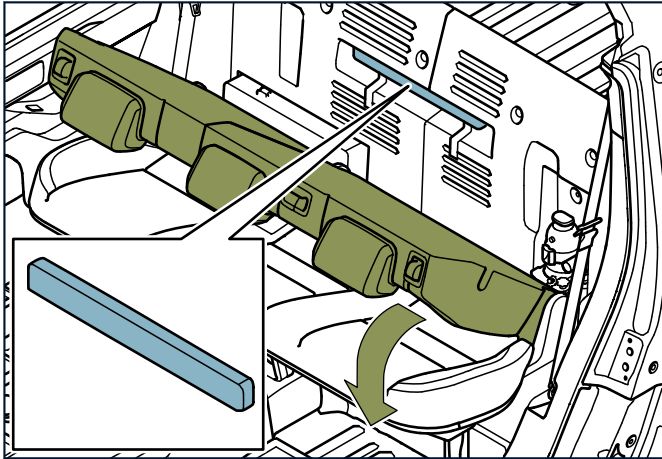

### Fire Extinguisher (if equipped)

The fire extinguisher, if equipped, is in front of the front passenger seat. INEOS recommends that you become familiar with the manufacturer's instruction label on the extinguisher before it is needed.

### AUTOMATIC CAR WASHES

The process below puts your Grenadier into a state for safe rolling for short distances.

1. Bring your Grenadier to a complete stop and continue to hold the brake pedal.
2. Shift into N (Neutral).
3. Turn off the engine, then immediately turn the key to the ACC (3) position without starting the engine.
4. The car wash function is engaged, and your Grenadier can be pushed.

If the ignition is not switched on, the Park position will be engaged after several minutes. If there is a malfunction, you may not be able to change the gears. If this happens call the nearest INEOS dealer for support.



## DRIVING OFF ROAD

---

INTRODUCTION .....	139
BEFORE DRIVING OFF-ROAD .....	139
WHILE DRIVING OFF-ROAD .....	139
GEAR RANGE AND CENTER DIFFERENTIAL .....	142
OFF-ROAD MODE .....	146
WADING MODE .....	147
DOWNHILL ASSIST .....	150
UPHILL ASSIST .....	151
RAISED AIR INTAKE (if equipped) .....	151
RAISED AIR INTAKE CYCLONE PRE-CLEANER (if equipped) .....	151

# DRIVING OFF ROAD

---

## INTRODUCTION

Driving off-road can be particularly dangerous. Seek specialist advice and training. There are many options: off-road driving schools, online courses, supervised off-road tracks, and much more. Even if you already have experience, consider taking your Grenadier on a supervised track to get used to driving it off-road before embarking cross-country.

## BEFORE DRIVING OFF-ROAD

- > Plan your journey in advance, consulting available resources (e.g., maps, rangers, online resources) in the process.
- > Make sure that you have the right off-road driving skills for the journey, and for any emergencies that may arise.
- > Make sure you have the time, fuel, supplies, capacities, and weather to get where you are going safely. Remember that when your Grenadier is on slopes gravity can pull low fuel levels beyond the intake in the fuel tank.
- > Anticipate and prepare for emergencies (e.g., tire disablement, power loss, sudden bad weather, accident, and injury) that may arise along the way. Make sure you will have the ability to call for help.
- > Notify someone who is not going along of your plans and agree on a check-in time.

- > Re-read and follow the instructions and precautions in the Cargo Loading and Securing section. Top-heavy, uneven, and unsecured loads are particularly dangerous off road. Remove all roof loads if at all possible.
- > Reread the entirety of this section beforehand.
- > Carefully inspect your Grenadier. Make sure it is in proper condition for whatever you might encounter.



**WARNING: Failure to follow these instructions and precautions may result in serious injury and death.**

## WHILE DRIVING OFF-ROAD

- > Follow all of the instructions and precautions in Seats, Seat Belts, Children in Car Seats and Booster Seats, and Air Bags section.
- > Take no unnecessary risks. Do not “think you can make it.”
- > Monitor the situation to make sure you still have the time, fuel, supplies, capacities, and weather to get where you are going safely.
- > Stop, get out and check the path forward if you cannot see it from your Grenadier or cannot confirm that it is safe to transit.

## DRIVING OFF ROAD

- > Be sure that the angles of approach and departure along your path are lower than those of your Grenadier and that you will not exceed the break-over angle, all of which are found in the Maintenance and Technical Information section.
  - > Stop and inspect your Grenadier from time to time. Don't wait for a warning light to appear.
- WARNING:** Failure to follow these instructions and precautions may result in serious injury and death.

Selecting the OFFROAD tab on the Center Display and Touchscreen and Touchscreen or the OFFROAD button on the Rotary Control will take you to screens that have helpful information.

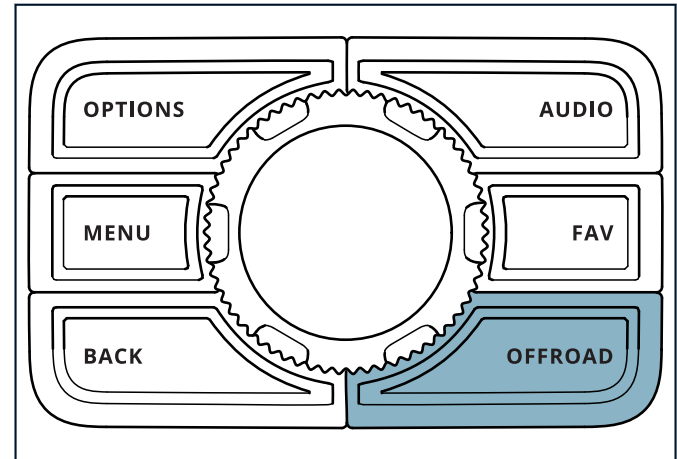

There are five views available:

- > ATTITUDE shows steering wheel angle, pitch angle, roll angle, G forces and altitude.

## DRIVING OFF ROAD



- > TEMPERATURE shows tire, automatic transmission, and transfer case temperatures and tire pressure.



- > PATHFINDER shows heading, location, altitude, atmospheric pressure and links to waypoints you can pre-program before your journey or navigate with a roadbook.



- > STATISTICS shows data for the current trip, including altitude, travel time and distance, average speed, average fuel economy and current location.



- > ELECTRICAL shows current charge, battery temperature, voltage, and state of charge.

# DRIVING OFF ROAD



## GEAR RANGE AND CENTER DIFFERENTIAL

### Powertrain overview

When taking your Grenadier off-road, you might need extra torque and slower speeds. The two-speed transfer case selector allows you to shift into a lower gear range. Use that range only while off-road and only when needed there.

For particularly difficult conditions, your Grenadier's center differential can be locked. Locking the center differential causes both axles to rotate at the same rate, mechanically locked through the center differential. This improves traction on uneven or slippery terrain.

### Shifting the transfer case selector

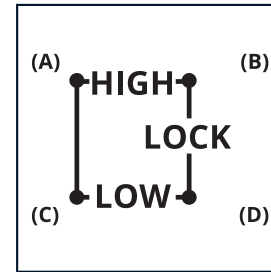

The transfer case selector is used to shift between the high and low gear ranges, and to lock and unlock the center differential, resulting in four possible positions.



**NOTE: Only HIGH, Unlocked (A) should be used on paved roads.**

The Telltale cluster will display  if a low gear range position is selected (C or D).

If the center differential is locked (B or D), the Telltale cluster will

display  and . Electronic Stability Control (ESC) operates in a limited off-road mode only (delayed ESC intervention), and Advanced Driver Assistance Systems (ADAS) are disabled. The differential and low range gears are designed for traction control at low speeds.

## DRIVING OFF ROAD

The center differential can be locked and unlocked with the transfer case selector while on the move so long as the axles are rotating at the same speed. Range changes require shifting to N (Neutral) on the automatic transmission.



### WARNING:

- > Do not drive at regular speeds or on public roads in LOW range.
- > None of the differentials should be locked on high traction surfaces, such as a paved road. A locked differential will severely impact the driving dynamics on high traction surfaces, making the vehicle unstable and dangerous to drive. This could result in an accident, injury, serious injury, or death.
- > Driver assistance systems designed for use on public roads are limited or disabled with a differential locked.

In some cases, shifting range with the transfer case selector can be difficult. **Do not force it.** Allow the Grenadier to roll forward a few inches to allow the internal mechanisms to align and attempt shifting again.

To shift the transfer case range:

1. Bring your Grenadier to a complete stop and continue to hold the brake pedal.
2. Shift the gear selector to N (Neutral).

3. Lift and hold the locking collar on the transfer case selector and shift it to the desired range position.

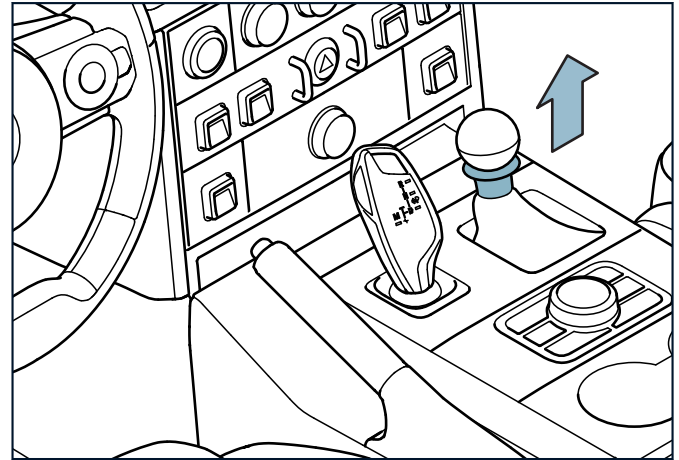

Always check that the transfer case selector is firmly engaged in one of the four positions before moving the gear selector from N (Neutral).

For extra control when driving in the low gear range, the gear selector can also be shifted in manual mode as described in the DRIVING ON ROAD section to manually select lower gears for crawling up hills or controlling descents.

# DRIVING OFF ROAD

## Front and rear axle differentials (if equipped)

If equipped, your Grenadier also has locking front and rear axle differentials, which distribute power evenly between both wheels on each axle for even greater off-road performance.



*NOTE: The front and rear differential locks can only be used if the transfer case is in low range and the center differential is locked:*

- > *The front and rear will not lock without the center locked and transfer case in low range.*
- > *If you unlock the center, the front and rear will also unlock.*
- > *If you shift from low to high range the front and rear differentials will be unlocked.*

*The front differential lock cannot be used without the rear:*

- > *The front will not lock without the rear locked.*
- > *If you unlock the rear differential before the front, both will be unlocked.*

*Do not lock the front or rear differential if any wheel is spinning (off the ground, in soft dirt, etc.).*

The front and rear differentials will not lock if ESC is actively assisting the driver.



**WARNING: All the warnings for the center differential apply to the axle differentials also. Additionally,**

- > Electronic Stability Control (ESC) and the Anti-Lock Braking System (ABS) are disabled when either axle differential is locked.
- > Steering is **severely** affected, particularly with the front axle differential locked.
- > None of the differentials should be locked on high traction surfaces, such as a paved road. A locked differential will severely impact the driving dynamics on high traction surfaces, making the vehicle unstable and dangerous to drive. This could result in an accident, serious injury or loss of life.



To lock the front or rear axle differential:

1. Start the engine if it isn't running.
2. Shift the transfer case to LOW LOCK.
3. Press and hold the appropriate differential lock button in the Overhead Control Panel for one second. Rear must be locked first, neither differential lock will activate if the front is pressed without the rear already engaged. You can do this while stopped or while driving slowly.

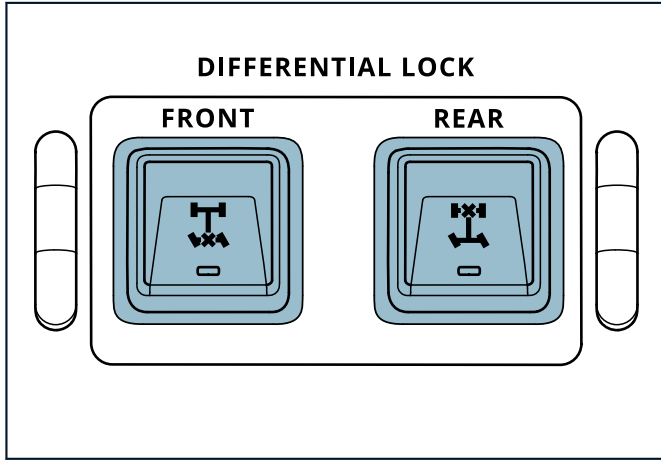
## DRIVING OFF ROAD



- > Drive forward at a speed below 9 mph (15 km/h) , pressing the accelerator pedal less than 40% of its total travel.

The corresponding indicator  or  will turn on in the Telltale Cluster:

- > Flashing orange indicates the differential lock is engaging.
- > Solid orange indicates the differential is successfully locked.

- > Solid red indicates a differential lock error, consult an INEOS dealer.

The differential locks must be engaged before the obstacle and disengaged immediately after overcoming the obstacle. Long-term use may lead to thermal overload and permanent damage to the system.

To disengage the front or rear differential lock, press the corresponding differential lock button in the Overhead Control Panel again. Unlocking the rear before the front will unlock both automatically. Unlocking the center differential first will unlock all three.











When unlocking the front and rear differential locks the vehicle operates a state check. The vehicle uses the wheel speed sensors to determine if the wheels across an axle are rotating at different speeds and thus proving the differential has unlocked. The check may take some time as it depends on the current vehicle movement to detect the correct state. Driving at low speeds while steering the vehicle left and then to the right, may reduce the state detection time.

### Range and locking combinations

The possible combinations for gear range and differential locking, the associated telltale indicators, and the effects on driver assist systems are shown in the table.



## DRIVING OFF ROAD

TRANSFER CASE SELECTOR POSITION	GEAR RANGE	CENTER DIFF.	REAR DIFF.	FRONT DIFF.	TELLTALES	EFFECTS
A	HIGH	-	-	-	-	-
B	HIGH	LOCK	-	-	 OFF	ESC Off-road, ADAS disabled.
C	LOW	-	-	-	L	-
D	LOW	LOCK	-	-	L  OFF 	ESC Off-road, ADAS disabled.
If equipped with front and rear axle differentials:						
D	LOW	LOCK	LOCK	-	L  OFF   (ABS)	ESC disabled, ADAS disabled, ABS disabled.
D	LOW	LOCK	LOCK	LOCK	L  OFF    (ABS)	ESC disabled, ADAS disabled, ABS disabled.

### OFF-ROAD MODE

Off-Road mode deactivates systems (Eco Start/Stop, Parking Sensors, Door ajar sound signals, Seat belt sound signals, and the Rear View Camera) that are useful on-road but that can interfere with off-road driving. It suppresses sound and visual signals from those systems to

help you to focus on the terrain ahead. Off-road mode also switches ESC to ESC Off-Road, which has reduced functionality (delayed ESC intervention).

## DRIVING OFF ROAD

To activate Off-Road Mode, while the engine is running and your Grenadier is parked, press and hold the OFFROAD button in the Overhead Control Panel for one second.

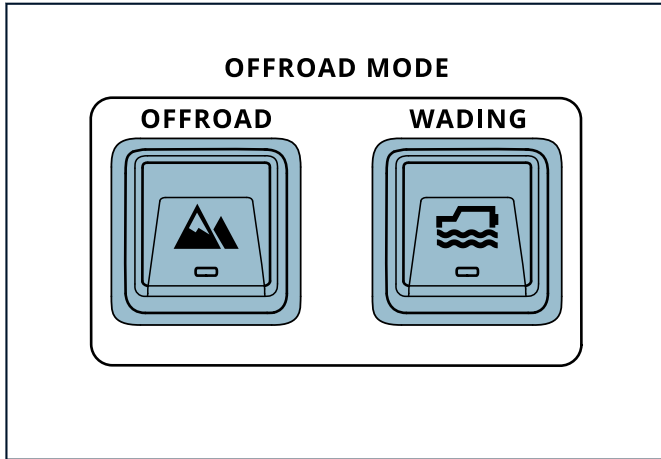

Release the button, then press it again within 15 seconds to confirm activation.

An audible confirmation that Off-Road Mode is active will be heard,

and the LED in the OFFROAD button will turn on. The  and  indicators will be displayed in the Telltale Cluster.

Off-Road Mode automatically deactivates if your Grenadier is driving faster than 44 mph (70 km/h) or if the engine is turned on after being off for longer than thirty seconds.

To manually deactivate Off-Road Mode, press and hold the OFFROAD button for one second again and release it. Off-Road mode will also deactivate automatically if the vehicle speed exceeds 44 mph or the engine is turned off for longer than 30 seconds.



**WARNING: Never activate Off-Road Mode when driving on-road. It disables safety features that reduce the risk of serious injury and death.**

### WADING MODE

#### Overview

Wading Mode deactivates certain features (Catalytic Converter, engine fans, Seat heating, Parking sensors, Seat belt reminder signal) and activates others (Air circulation mode, speed governor) for short, low speed traverses of relatively shallow, still or nearly-still waters.

The maximum wading depth is 31.5 in. (80 cm) , which is about the height of the top of your Grenadier's factory fitted tires. Do not exceed that depth.

Recommended maximum speed while wading is 3 mph (5 km/h) . Any faster and you risk creating a bow wave that could enter the air intakes and cause irreversible engine damage (hydro lock). Do not exceed that speed. A 18 mph (30 km/h) speed limit is activated in

## DRIVING OFF ROAD

wading mode to protect the vehicle yet allow sufficient wheel slip and therefore wheel speed if necessary.

Maximum continuous wading duration is 20 minutes. Wading for longer than that can damage and even disable your Grenadier. Do not wade longer than necessary or 20 minutes, whichever is shorter.

Moving water is extremely powerful. It can topple and carry off any vehicle, including your Grenadier. The deeper the water, the greater the risk. The faster the water, the greater the risk. Do not attempt to traverse any other than still or nearly-still waters.

Flooded roads are dangerous. If water has come onto a road, it may have carried objects with it. Those objects and the roadside may be obscured. Do not assume that a flooded road is the same as a non flooded road. It isn't. Stay off flooded roads if possible.

Water depths and flow rates can change violently and without warning. Assess the risk of such changes before traversing.

Traversing water-covered paths and roads can be extremely dangerous. Do not do so unless necessary. Flooding is not an opportunity to see what your Grenadier can do or to demonstrate for others.

Do not wade with occupants who cannot get out of a toppled vehicle and who cannot swim.

Do not take unnecessary risks to wade or while wading.



**WARNING: Failure to follow these instructions and precautions may result in serious injury and death.**

### Before Wading

Before entering the water in your Grenadier, plan and survey your route. Check depth and flow rate for the duration of the traverse. Be sure that the angles of approach and departure are lower than those of your Grenadier and that you will not exceed the breakover angle, all of which are found in the Maintenance and Technical Information section.

Secure the drainage plugs in each of the four foot-wells in your Grenadier and in the cargo area.

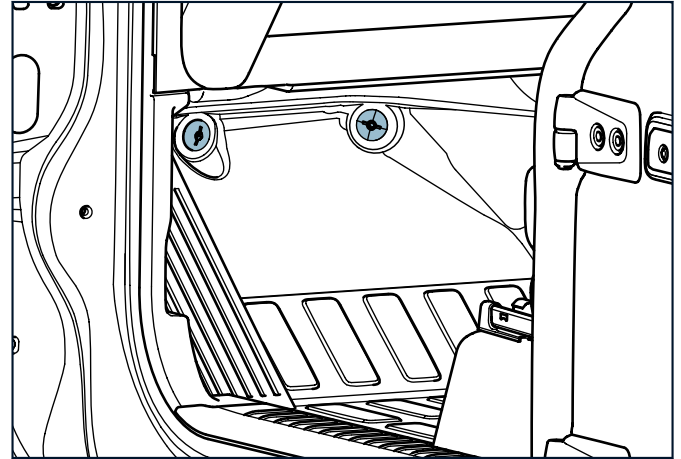

## DRIVING OFF ROAD

Removing the tailgate scuff plate at the rear of the vehicle will allow access to the drainage plug in the cargo area.

Close all doors.

If equipped, turn off the winch isolation circuit in the Overhead Control Panel (labeled EXT4). Ensure that the NATO outlet cover is tightly closed (IPX8 rated). Do not plug any cables into a live power outlet, if the vehicle has been driven in the rain and/or been taken wading without the power outlet cover being fully closed. It is advised to apply a silicon based lubricant to the NATO outlet cover threads from time to time to prevent seizure.

### Wading



To activate Wading Mode:

- > Your Grenadier's engine must be running.
- > Your Grenadier must be stopped.
- > The Transfer Case must be in LOW.
- > The Center Differential must be engaged.

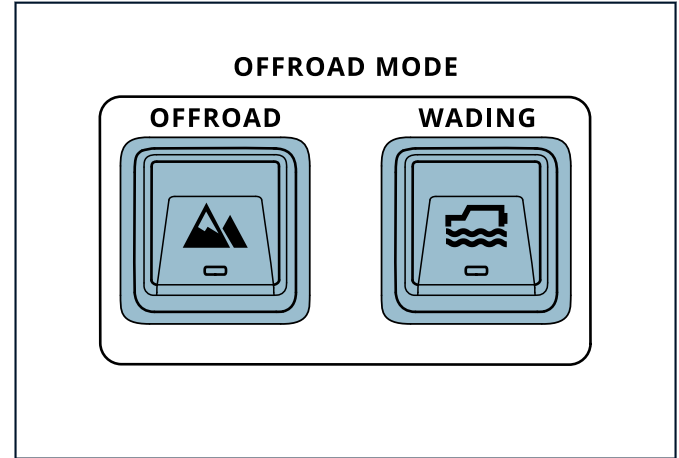
Press the Wading Mode button  located on the Overhead Control Panel for approximately one second.



Release the button, then press it again within 15 seconds to confirm activation. An audible confirmation that Wading Mode is active will be heard, and the LED in the WADING button will turn on. Wading Mode

also activates Off-Road Mode, and the  and  indicators will be displayed in the Telltale Cluster. If your Grenadier does not send these sound and visual signals, you are not in Wading Mode. Under

## DRIVING OFF ROAD

no circumstance should you go wading. You will risk injury and vehicle damage.

### While Wading

Be attentive to water depth, water flow, pitch and roll angles, and tire contact. If you sense danger, remove yourself from that danger by way of the safest available alternative.



**WARNING: Failure to follow these instructions and precautions may result in serious injury and death.**

### After Wading

To deactivate Wading Mode, press and hold the WADING button for at least one second and release it. Shifting the transfer case to a high gear range, unlocking the center differential, and deactivating Off-Road Mode will also disable Wading Mode.

Let the vehicle idle for a minimum of 20 minutes or drive the vehicle for 20 minutes immediately afterward.

Wet brakes will be less effective at stopping the vehicle than dry ones so exercise caution.

### DOWNHILL ASSIST

Downhill Assist helps control the speed of your Grenadier when going downhill at very slow speeds by automatically applying braking force independently to each wheel to slow your Grenadier and to

reduce the risk of spinning or plowing. It will not stop your Grenadier. The driver must remain vigilant and in control.

Downhill Assist will not activate if:

- > Your Grenadier is traveling forward faster than 15 mph , or reversing faster than 6 mph .
- > The front or rear axle differential is locked.
- > Electronic Stability Control (ESC) is deactivated.

To Activate Downhill Assist, press the DOWNHILL button on the Overhead Control Panel.

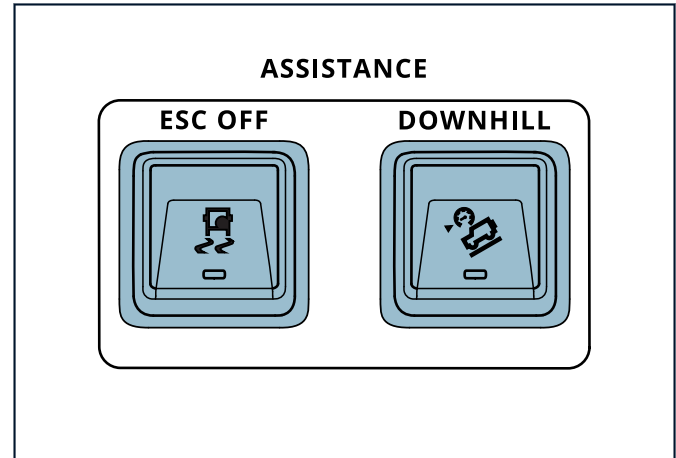

## DRIVING OFF ROAD

When active, the Center Display and Touchscreen will include the Downhill Assist symbol in green next to the speed. The same symbol will flash when Downhill Assist is in control of braking.

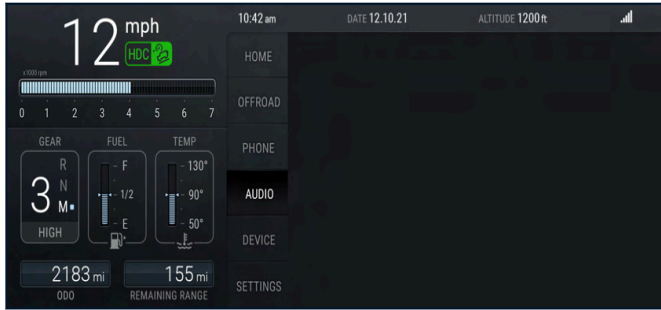

Set the downhill speed using the RES+ and SET- buttons on the steering wheel.

To Deactivate Downhill Assist, press the DOWNHILL button again.

Downhill Assist will also deactivate automatically if the driver accelerates over 15 mph forward or 6 mph reverse, ESC Off is pressed, or if axle differential locks are engaged.

### UPHILL ASSIST

Uphill Assist is a driving aid designed to hold the vehicle for a short time when climbing a hill. It is the driver's responsibility to make sure that the vehicle does not roll back even when the feature is active.

The appropriate gear must be selected depending on the direction of travel for the feature to become active. Uphill assist is not available when neutral is selected. If the rear and/or front differential is locked, then Uphill Assist will not be available. If the vehicle is in gear, and there is a gradient of 3% or more detected, then the vehicle is held stationary for two seconds after the brake pedal is released.

### RAISED AIR INTAKE (if equipped)

Raising the position of the engine air intake helps feed the engine with cleaner and cooler air in dusty environments. The Raised Air Intake does not improve wading performance or maximum wading depth.

### RAISED AIR INTAKE CYCLONE PRE-CLEANER (if equipped)

This attachment uses cyclone technology to spin the air at high speed before it enters the raised air intake air duct.. This provides a centrifugal effect to any dust and dirt, preventing contaminants from entering the engine air intake. This is recommended for very dusty and dirty environments.

# TOWING A TRAILER

---

INTRODUCTION .....	153
CHOICE OF TRAILER .....	153
TOWING CAPACITIES .....	153
CHECKING THE TRAILER AND LOAD .....	154
CONNECTING THE TRAILER .....	154
ADJUSTING THE MIRRORS .....	154
DRIVING WITH A TRAILER .....	155
TRAILER STABILITY ASSIST .....	155
PARKING WITH A TRAILER .....	156
UNHITCHING WITH THE TRAILER .....	156

# TOWING A TRAILER

## INTRODUCTION

The 2-inch hitch receiver tube in the Grenadier's Vertical Towing Interface is designed to accommodate standard American ball mounts. It also has mounting holes for European tow balls, NATO hitches, and pintle hitches. Depending on the weight and type of your trailer, choose a hitch that suits your needs and complies with all local laws for your intended use. Make sure the hitch is correctly installed and has a rating that will more than accommodate the weight of the loaded trailer.

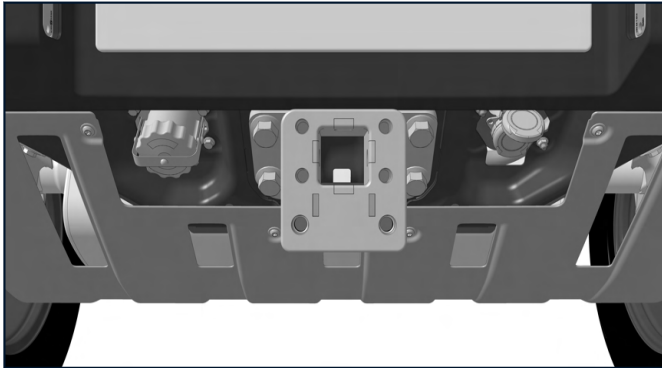

If equipped your Grenadier will have a 7 flat pin trailer electrical connector.

Towing a trailer is particularly demanding. Read and follow the instructions and precautions that follow.

## CHOICE OF TRAILER

Make sure that you choose a trailer that complies with all applicable laws and regulations. Check with your local motor vehicle department or division and with recognized authorities, such as, the National Highway Traffic Safety Administration. (See, e.g., <https://one.nhtsa.gov/cars/problems/equipment/towing/>).

## TOWING CAPACITIES

The following are your Grenadier's towing capacities. Remember that the weight of the trailer tongue needs to be included in any calculation of your Grenadier's remaining weight capacity after accounting for the driver and passengers.

Trailer with Trailer Brakes	7,716 lb. (3,500 kg)
Trailer without Trailer Brakes	1,653 lb. (750 kg)
Trailer Tongue Weight	771 lb. (350 kg)

Never abuse your Grenadier by subjecting it to greater overall loads than it was designed to handle.

A driver's capacity to manage a trailer may be different from the capacities mentioned above. See the Driving with a Trailer subsection below.

A trailer's capacity may be different from your Grenadier's capacity.



# TOWING A TRAILER

---

## CHECKING THE TRAILER AND LOAD

- > Read your trailer's owner's manual. Follow all of the instructions and precautions in it.
- > Inspect the trailer and all of its components (e.g., tires, spare, winch, hooks, tie-downs, straps) and make sure that they are in good condition and working order.
- > Make sure that the trailer load is evenly distributed according to the trailer's owner's manual (usually about 60% of the weight toward the front and 40% toward the back).
- > Make sure the load is secure to prevent shifting during transit and on slopes (e.g., boat ramps).

## CONNECTING THE TRAILER

- > Read your trailer's owner's manual. Follow all of the instructions and precautions in it.
- > Clear the area behind your Grenadier. Keep others, especially children and pets, clear.
- > Carefully back your Grenadier up to the trailer, aligning the hitch with the trailer's coupler.
- > Put your Grenadier in P (Park) and set the Parking Brake.
- > Turn your Grenadier off.

- > Lower the coupler onto the hitch ball until it's fully seated, then lock it in place. Make sure that there is plenty of ground clearance, remembering that you may have to drive over elevation changes (e.g., speed bumps, driveway entries).
- > Connect safety chains in a crisscross pattern under the hitch and to the hook retainers on the Grenadier's Vertical Towing Interface. (This creates a safety net in case the main connection fails.) Never connect the safety chains to the Grenadier's towing eye hooks or bumper. Make sure the chains are loose enough to allow turns, but tight enough to avoid dragging on the ground.
- > Attach the wiring harness from the trailer to 7 flat pin connector on the vehicle. Make sure it's secure and that the wires will not get abraded, pulled or broken.
- > Turn your Grenadier back on.
- > Make sure all lights on your Grenadier and your trailer (brake lights, turn signals, and running lights) are operational by actually looking at them.

## ADJUSTING THE MIRRORS

Make sure you have a clear view of the trailer and its surroundings. If necessary, install extended side mirrors.

# TOWING A TRAILER

## DRIVING WITH A TRAILER

- > Read your trailer's owner's manual. Follow all of the instructions and precautions in it.
- > Follow local laws.
- > Get training from local officials or reputable sources if you are not experienced.
- > Get information from reputable sources about how to trailer. See, e.g. <https://one.nhtsa.gov/cars/problems/equipment/towing/> and <https://www.consumerreports.org/car-safety/preparation-and-driving-tips-for-safe-towing/> and.
- > Make sure you are ready. Pulling a trailer requires even more attention than normal driving.
- > Shift into D (Drive) and release the parking brake when you are ready and both the path before your Grenadier and the path before your trailer and its wheels are clear.
- > Start slowly and drive a few feet to make sure that everything is working and that connections are secure.
- > Remember, your Grenadier will need more distance to stop when towing. Increase your following distance.
- > When turning, wider turns are necessary to avoid the trailer cutting corners.
- > When changing lanes, you must account for the trailer.
- > Monitor all gauges, especially the temperature. Towing puts additional strain on your engine.

- > When driving uphill or with a heavy load, reduce speed and shift to a lower gear if necessary.
- > When driving downhill, use engine braking, when possible, to reduce strain on brakes.
- > Be mindful of crosswinds and gusts, which can cause the trailer to sway.
- > Assess off road areas, even grassy areas and unpaved parking lots, before putting a loaded trailer on them. Loaded trailers can be very heavy and can get stuck.
- > Be sure you are comfortable with backing a trailer before backing it up. Use a spotter if possible.



### NOTE:

Hold the steering wheel on the bottom when backing. Push your hand and the wheel in the direction you want the trailer's wheels to go (i.e., push the steering wheel to the left if you want the trailer wheels to go to the left, and to the right if you want the trailer wheels to go to the right.) That also reduces the risk that you will over-steer.

## TRAILER STABILITY ASSIST

If towing devices have been factory equipped, your Grenadier's Electronic Stability Control (ESC) system has a calibration for towing.

## TOWING A TRAILER

---

Trailer Stability Assist helps to control individual wheel slip to reduce the risk of trailer sway.

ESC must be in default mode for Trailer Stability Assist to operate. When Trailer Stability Assist is actively supporting the driver, the telltale  lamp will blink to alert the driver.

### PARKING WITH A TRAILER

Read your trailer's owner's manual. Follow all of the instructions and precautions in it.

Always use wheel chocks, in addition to the parking brake, to reduce the risk that the trailer will roll (and take your Grenadier with it). If parked for an extended period, disconnect the trailer's wiring harness to avoid draining the battery.

### UNHITCHING WITH THE TRAILER

- > Park the vehicle and trailer on level ground. Put your Grenadier in P (Park), set the Parking Brake, and turn your Grenadier off.
- > Place wheel chocks in front of and behind at least two of the trailer's tires, at least one on each side of the trailer. (If you chock only one tire and only one side, the un-chocked tires could roll, pivoting the trailer around the chocked tire(s)).

- > Disconnect the wiring harness and safety chains.
- > Carefully lift the trailer coupler off the hitch ball.



**WARNING:** Failure to follow the instructions and precautions in this section could result in serious injury and death.

# TRANSPORTING YOUR GRENADIER

---

INTRODUCTION .....	158
PREPARING YOUR GRENADIER FOR TRANSPORTING .....	158
TRANSPORTING YOUR GRENADIER .....	159
EMERGENCY TOWING WITH FOUR WHEELS ON THE GROUND .....	159
RECOVERY .....	159
AFTER TOWING OR TRANSPORT .....	160

# TRANSPORTING YOUR GRENAДИER

## INTRODUCTION

This section explains what you must do if your Grenadier is to be transported (e.g., carried, towed away, pulled away).

## PREPARING YOUR GRENAДИER FOR TRANSPORTING



**WARNING: N (Neutral) is not for moving your Grenadier significant distances. Do not push or roll your Grenadier in N (Neutral) more than required to avoid damage to your Grenadier's drivetrain. If you need to pull your Grenadier, even for short distances such as moving it to the roadside or winching onto a flatbed truck:**

- > Do so only for short moves such as getting to a nearby road or pavement. Keep speeds below 30 mph (48 km/h).
- > Make sure the vehicle is stable and won't roll by using chocks.
- > Set the parking brake.
- > Shift the automatic transmission to neutral.
- > If locked, unlock the center differential.
- > Position the transfer case selector midway between LOW and HIGH range.
- > Locate the NEUTRAL bolt on the underside transfer case.

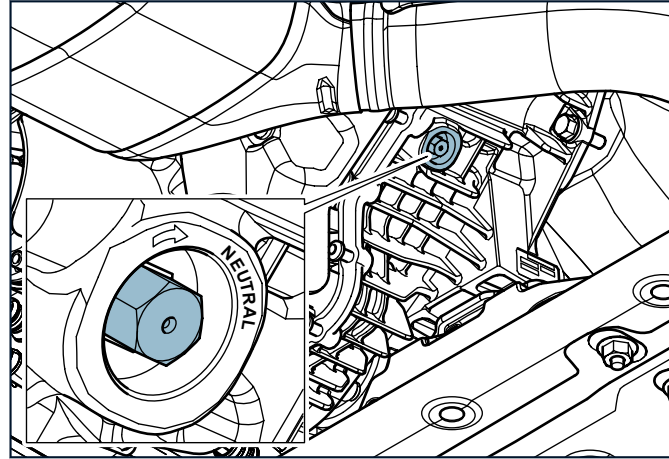

- > Carefully turn the NEUTRAL bolt clockwise until it is fully in. Do not use power tools. The transfer case will then be in neutral.
- > Turn the key to the first position to unlock the steering wheel. Leave the key in the ignition switch while towing. If engine is on the automatic transmission must be in N (Neutral).
- > With your Grenadier hooked up to the tow vehicle, release the parking brake and remove the wheel chocks. Your Grenadier will roll freely.

# TRANSPORTING YOUR GRENADE

**If there's a transmission issue or wheel/tire damage, don't tow the vehicle. Only transport it on a flatbed truck. Towing a vehicle with these problems will cause more damage.**

## TRANSPORTING YOUR GRENADE

Your Grenadier is best transported using a flatbed truck or other system that lifts all four wheels so that none roll on the pavement or ground. Towing with tires on the ground can damage the drivetrain or related parts.

If you must call a towing company, make sure to explain that you need a flatbed truck or some other similar system to get all four wheels off the ground.

Follow the instructions in Preparing Your Grenadier for Transporting before moving your Grenadier onto the flatbed truck.

## EMERGENCY TOWING WITH FOUR WHEELS ON THE GROUND

If you must tow with any wheels rolling on the ground, make sure that it is all four wheels and not just the two front or two rear wheels. Follow the instructions in Preparing Your Grenadier for Transporting, Towing, or Recovery. Towing with only two wheels on the ground will damage your transmission.

## RECOVERY

In an emergency and in the absence of a flatbed tow truck, your Grenadier can be towed for very short distances by using cables or chains attached to the emergency towing hooks.

You must follow the instructions in Preparing Your Grenadier for Transporting before recovering it to avoid transmission damage.

This method should only be used on hard-surfaced roads for very short distances and at low speeds. It may be used for recovery when off-road if there are no other options, but only for a distance sufficient to switch to one of the other methods of towing described previously. It's imperative to have a driver inside the vehicle to steer and manage the brakes. Additionally, make sure that the vehicle's wheels, drivetrain, axles, steering, and brakes are in optimal condition before proceeding.

Your Grenadier is equipped with two front and two rear towing eyes attached to the frame. Do not exceed their maximum load ratings:

VEHICLE END	LOAD DIRECTION	MAXIMUM LOAD
Front	Horizontal	8,992 lbf. (40 kN)
	Vertical	6,744 lbf. (30 kN)
Rear	Horizontal	7,868 lbf. (35 kN)
	Vertical	5,058 lbf. (22.5 kN)

Use only one towing eye on the end of the vehicle you are towing from, and always use a tow strap with an appropriate load rating.

# TRANSPORTING YOUR GRENADIER

---

## AFTER TOWING OR TRANSPORT

When you are ready to put your Grenadier back into service:

- > Make sure the vehicle is stable and won't roll by using chocks.
- > Set the parking brake.
- > Shift the automatic transmission to N (Neutral) if engine is on or P (Park) if engine is off.
- > Carefully turn the NEUTRAL bolt counterclockwise only until it is flush with the surrounding case. Overturning the bolt or removing it can severely damage the transfer case.
- > Shift the automatic transmission to Park (P) before releasing the parking brake.

# WINCHES

---

INTRODUCTION .....	162
FRONT INTEGRATED HEAVY-DUTY WINCH (if equipped) .....	162
REMOVABLE REAR WINCH (if equipped) .....	164
REMOTE CONTROL .....	166
ATTACHMENT DEVICES .....	169
OPERATING A WINCH .....	169
WINCH TROUBLESHOOTING .....	171
WINCH SERVICE AND MAINTENANCE .....	175
WINCH LOAD LIMITS .....	176



# WINCHES

## INTRODUCTION

The winches for your Grenadier were designed, manufactured, and tested by Red Winches Limited. They are for self-recovery only. They must never be used for any other purpose, including towing.

These winches must never be used without appropriate training and instruction. You can get such instruction from many off-road driving schools, clubs, and organizations, at events and workshops, and from local authorities.

This section is a guide only and is not intended as a substitute for proper training and instruction. This section cannot and does not address all situations and all conditions that might arise. It is up to the user to know the contents of this section and to use it and all other available information to spot and react appropriately to conditions then and there existing.

## FRONT INTEGRATED HEAVY-DUTY WINCH (if equipped)

The Front Integrated Heavy-Duty Winch is located in the center of the front bumper. It is rated to pull 12,000 lb. (5,500 kg).

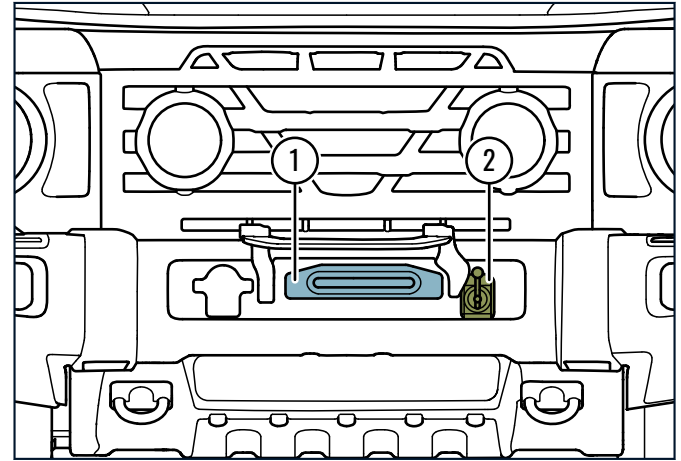

Its fixed components are a fairlead (1) which helps direct the winch rope onto the drum in a smooth and aligned manner. (The drum is behind the fairlead). The winch rope is stored on the drum and is routed through the fairlead for use. A freespool lever (2) activates a clutch. When it is vertical, the clutch is engaged, and the drum is held in place by the winch motor. When it is horizontal, the clutch is disengaged, and the winch rope can be pulled off of the drum.

## WINCHES

---

Disengaging the clutch is useful for extending the rope without using the winch motor.

The lever is in the freespool position when it is in either horizontal orientation.

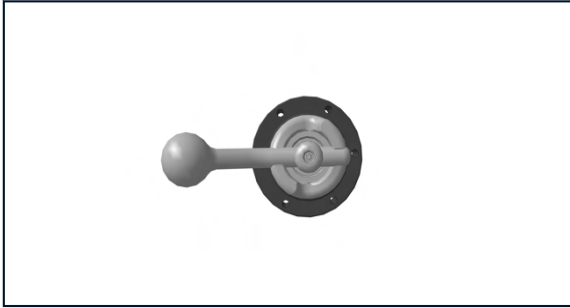

The lever is in the locked position when it is in either vertical orientation.

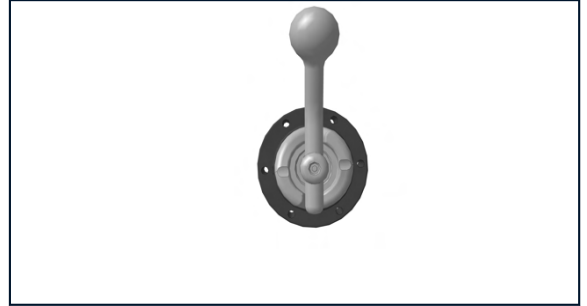

## WINCHES

If your state requires front license plates, you may need to move the spring loaded license plate holder by pushing it to the left and up to get to the winch.

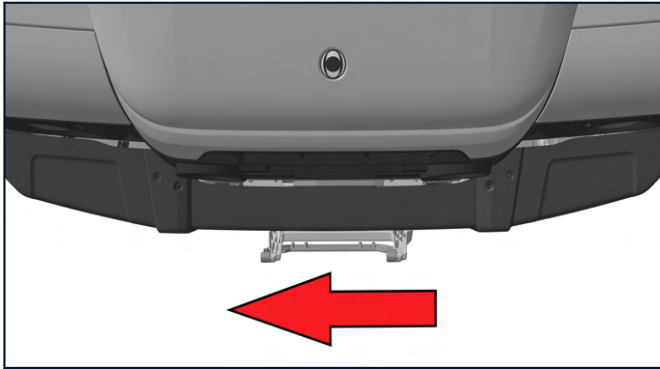

### REMOVABLE REAR WINCH (if equipped)

A rear winch may have come with your Grenadier, or you may order one to add (Removable Rear Winch requires High Load Auxiliary Switch Panel & Electrical Preparation option). It too was designed, manufactured, and tested by Red Winches Limited. It can be

mounted in your Grenadier's square hitch receiver tube (if equipped). It is rated to pull 7,700 lb. (3,500 kg.) .

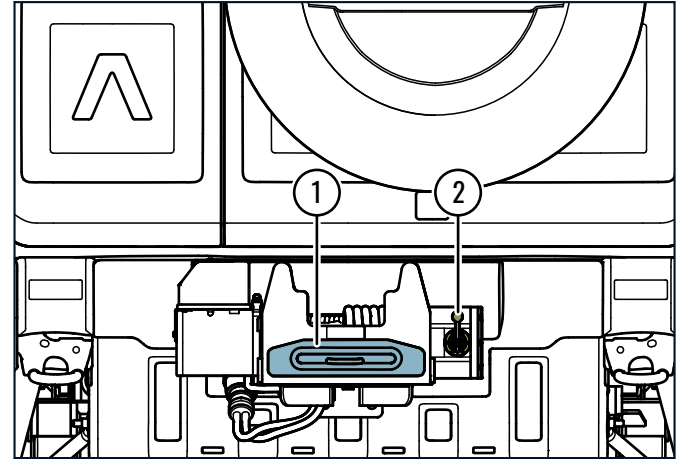

It has the same fixed components fairlead (1) and freespool lever (2) as the front winch except that it also has a locking pin for the square hitch receiver tube and a power cable that must be attached.

# WINCHES

## Mounting and dismounting your rear winch

To mount your Removable Rear Winch:

1. Park your Grenadier safely with room to work behind it.
2. Be sure the winch isolation circuit (labeled EXT4) is switched off on the Overhead Control Panel before handling the NATO wiring connector.
3. Remove any towing devices from the towing hitch receiver.
4. Inspect and remove any debris from the 2" receiver tube in the center of the hitch receiver.

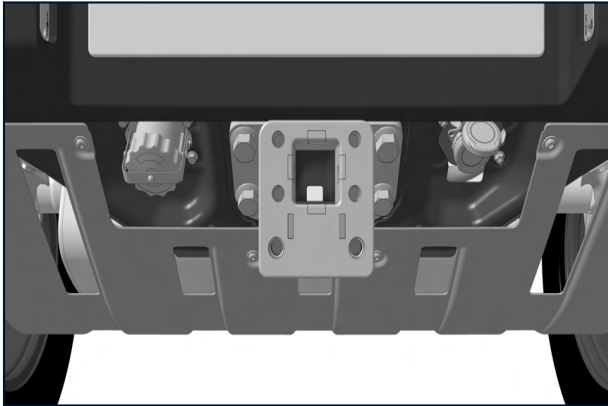

5. Insert the Removable Rear Winch into the 2" Receiver, ensuring the locking pin is correctly installed and secure with the R-Clip.

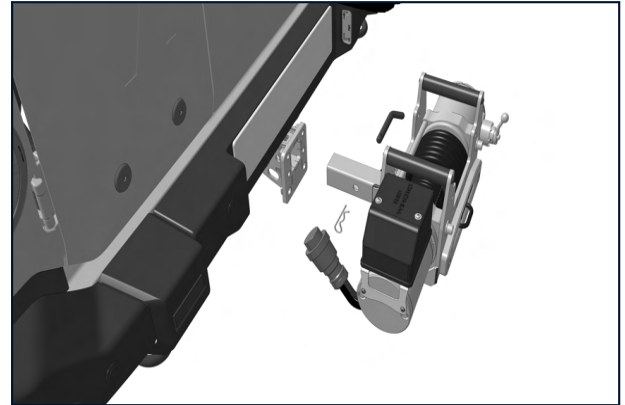

6. Inspect the Removable Rear Winch electrical cable for damage or wear.

# WINCHES

7. Unscrew the NATO outlet cover.



8. Inspect and remove any debris from the outlet.
9. Plug the Removable Rear Winch's power cable into the outlet.

Reverse the steps to dismount the Removable Rear Winch, ensuring the winch isolation circuit (labeled EXT4) is switched off on the Overhead Control Panel before handling the NATO wiring connector.

After dismounting, stow the Removable Rear Winch safely before driving your Grenadier. It must be properly secured with straps or another appropriate tie-down system. Store the winch as low as possible in your Grenadier and make sure that there is no movement when the Winch is secured.



**WARNING:** Failure to follow these instructions and precautions could result in serious injury and death.

## REMOTE CONTROL

### Overview

Each winch is controlled with a battery-operated wireless remote control with three buttons and a signal lamp.

### FCC Notice

#### FCC notice

This device complies with Part 15 of the FCC Rules. Operation is subject to the following two conditions: (1) This device may not cause harmful interference, and (2) This device must accept any interference received, including interference that may cause undesired operation.

# WINCHES

Changes or modifications not expressly approved by the party responsible for compliance could void the user's authority to operate the equipment.

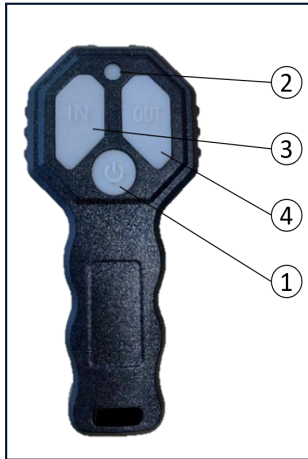

1. Power Button
2. Power Light (lit when the Remote is ON)
3. Spool In (to pull the rope back into the winch)
4. Spool Out (to release rope out of the winch in a controlled way)

## Remote control battery replacement

Your Winch remote control is battery powered. If you find that its electronic functions are not working or its range is reduced, you may need to replace the battery.

The Winch Remote Control requires 2x AAA (3v) batteries.

### To replace the battery:

- > Loosen and remove the 3 screws on the rear of the winch remote control and separate the two halves.
- > Remove the old batteries.
- > Insert the new batteries.
- > Secure the two halves of the housing back together and tighten the 3 screws on the rear of the winch remote control.
- > Test to see that the winch remote controls are working.

Properly recycle used batteries. Don't dispose of them in regular trash. Follow environmental guidelines for disposal.

# WINCHES

## Winch remote control warnings



### WARNING:

- > Never leave children or pets alone in a vehicle or leave children with access to a winch remote control.
- > Keep batteries away from children. If swallowed, batteries can cause serious injuries within two hours that can lead to serious injury and death. If you suspect that a battery may have been ingested, seek medical attention immediately.
- > If the Winch remote control cover isn't secure, stop using it, keep it away from children, and have it repaired or replaced by your INEOS dealer.
- > Avoid exposing the winch remote control to extreme heat, dust, humidity, or direct sunlight. Keep it away from liquids.

## Pairing

To pair a remote control with a winch:

1. Set the parking brake.
2. Start the engine.
3. Check that the winch circuit isolator in the Overhead Control Panel (labeled EXT4) is off.

4. Shift the transmission into N (Neutral).
5. Press and hold the power button (1) on the winch remote for three seconds to turn it on. The LED (2) will illuminate.
6. Press and hold the Spool In (3) and Spool Out (4) remote control buttons simultaneously.
7. While continuing to hold the remote control buttons, switch on the winch circuit isolator.
8. Wait three seconds, and then release the remote control buttons.
9. Test the control of the winch with the remote control.

## Important information if you have two winches

If your Grenadier has both the Front Integrated Heavy-Duty Winch and the Removable Rear Winch installed simultaneously, be careful not to accidentally link one remote to both winches. The Grenadier powers both winches through one circuit. When activated, both winches enter a temporary pairing mode, which might cause one remote to connect to both by mistake.

To pair your remote controls with your winches:

1. LABEL each remote control. It is important that the front winch and rear winch are controlled by separate remotes, and equally important to know which is which.
2. Pair the Front Integrated Heavy-Duty Winch and remote control first.

# WINCHES

3. Disconnect the Removable Rear Winch power cable from your Grenadier.
4. Follow the Pairing instructions below to pair the front winch with the front winch remote control.
5. Pair the Removable Rear Winch and remote control second.
6. Make sure the Removable Rear Winch power cable remains disconnected from the previous step.
7. Start the Engine.
8. Shift the transmission to N (Neutral) and set the parking brake.
9. Switch on the winch circuit isolator in the Overhead Control Panel, labeled EXT4.
10. Wait for one minute to allow the Front Integrated Heavy Duty Winch control unit to exit pairing mode.
11. Press and hold the power button (1) on the winch remote for the rear winch for three seconds to turn it on. The LED (2) will illuminate.
12. Press and hold the Spool In (3) and Spool Out (4) remote control buttons simultaneously.
13. While continuing to hold the remote control buttons, reconnect the Removable Rear Winch power cable to the Grenadier. The rear winch will now power up in pairing mode.

14. Wait three seconds, and then release the remote control buttons.
15. Test the control of the rear winch with the remote control.

## ATTACHMENT DEVICES

Always use a RED Winch S-Ring 50 snatch ring in the soft loop at the end of the winch rope. Do not use any other attachment.



**WARNING: Use of any other attachment increases the risk of serious injury and death.**

## OPERATING A WINCH

- > There are risks associated with any use of a winch. Use a winch only when necessary.
- > Unload your Grenadier as much as possible before winching. Any load in your Grenadier adds to the load on the winch.
- > Always have a minimum of two people conduct winching operations. The tasks involved (e.g., attaching the winch, clearing the area, shifting into N (Neutral), operating the winch, keeping an eye on the rope and your Grenadier, knowing when your Grenadier is freed, stopping and securing your Grenadier, relaxing and uncoupling the rope) are too much for one person to handle safely.



## WINCHES

- > Anyone within range of the winch rope when it is under load or may rebound if parted must wear appropriate protective gear, including gloves and eye protection, and avoid getting anything (e.g., clothing, hair, body parts) caught by the winch rope. Make sure everyone who is not necessary for winch operation is clear.
- > Thoroughly inspect the winch rope, controls, and related equipment before (and after) each use. Replace any damaged parts before driving to a location where the winch might be needed.
- > Pull or motor out enough rope to reach your anchor or until the red line on the rope is visible from the driver seat, whichever comes first.
- > Attach the RED Winch S-Ring 50 snatch ring to an anchor that is centered with the winch. Do not use the winch for side pulls.
- > Make sure that the attachment and the anchor to which you attach it will remain fixed under the pulling load.
- > Everyone must stay a safe distance from the winch rope, the anchor, and the outside of your Grenadier during winching operations. A "safe distance" includes the entire area in which a parted rope, attachment or object may fly or rebound.
- > A winch can be operated only while your Grenadier's transmission is in N (Neutral), D (Drive) or R (Reverse). You must make sure that your Grenadier will not roll and that the area around it is clear before placing it in N (Neutral).

- > If the freespool lever is not secure in the freespool or locked positions, pull the winch rope out slightly to turn the drum while applying gentle pressure to the lever to allow the internal components to mesh.



**WARNING: Failure to follow these instructions and precautions will increase the risk of serious injury and death.**

### To use a winch:

1. Set the parking brake.
2. Start the engine.
3. Switch on the winch circuit isolator in the Overhead Control Panel (labeled EXT4).
4. Shift the transmission into N (Neutral). Your winch will not operate with your Grenadier in P (Park).
5. Press and hold the power button (1) on the winch remote for three seconds to turn it on. The LED (2) will illuminate.
6. Move the winch freespool lever to the freespool position (horizontal orientation).
7. Extend the winch rope manually and anchor the end safely.
8. Move the winch freespool lever to the locked position (vertical orientation).
9. Press and hold the Spool In (3) button on the remote to retract the winch rope until it is pre-tensioned.

# WINCHES

10. Return to the driver's seat and shift the transmission to N (Neutral), R (Reverse), or D (Drive) as needed.
11. Press the brake pedal.
12. Release the parking brake.

You can now control both your Grenadier and the winch as needed to complete your winching operation, pressing the Spool In (3) and Spool Out (4) buttons as needed on the winch remote.

## When your winching operation is complete:

1. Set the parking brake.
2. Shift the transmission N (Neutral).
3. Release the tension on the winch rope with the winch remote control.
4. Remove the winch rope from its anchor.
5. Inspect the winch rope for damage.
6. Using the winch remote control, spool the winch rope back onto the drum.
7. Switch off the 500 Amp winch circuit isolator in the Overhead Control Panel, labeled EXT4.
8. Be aware of heat generated by the winch and potential fire hazards.

## WINCH TROUBLESHOOTING

The notes that follow are general guidelines only. Use your own judgment to best determine when the Winch needs to be serviced based on the activities where the Winch has been used.

Please contact your INEOS dealer if you are experiencing any difficulties, including any of the guidelines listed in this subsection.

### Winch motor gets hot very quickly

- > The winch may be overloaded or could have stalled during operation. Make sure the load is within the winch's rated capacity.
- > Issues such as a weak connection to the battery, a worn-out winch motor, or the presence of water or mud in the winch motor might be responsible. Inspect all connections and cables.

### Winch has no power

The issue might stem from a variety of factors (e.g., motor fault, weak ground connection, depleted battery, malfunctioning isolator switch, damaged winch remote control, depleted remote control battery, compromised cable, faulty switch). To diagnose:

- > Make sure the winch isolator is ON. You can find the 500A switch on the Overhead Control Panel, labeled as EXT4.
- > Verify that your Grenadier's gear selector isn't set to P (Park).

# WINCHES

---

- > Assess your Grenadier's battery condition. The battery must maintain a charge above 55% to operate the winch. If it drops below 50%, the winch will be automatically turned off.
- > Inspect for continuity between the 150A circuit breaker terminals located in the engine bay.
- > Examine the cable connections on the winch motor, which can be found under the front and rear sections of your Grenadier.
- > Confirm that the motor control solenoid is operational. It's situated inside the front right fender of your Grenadier, right behind the right headlamp.

## Winch lacks pulling power

- > Make sure the Freespool Lever is set to the "disengaged" or vertical position and pressed securely against the cam's lowest point. If the lever doesn't press fully against this section, pull the winch rope out slightly by hand to rotate the winch drum to align the Freespool lever with the internal mechanism, allowing it to securely press against the lower most part of the cam extrusion.
- > Make sure the winch rope is not slipping on the drum. If you notice slippage, stop the motor immediately and wait until the drum stops completely. Once it's safe, pull out the winch rope until you see a red mark, then rewind it tightly.
- > Turn off any electrical accessories in your vehicle, such as lights or heated seats.

- > Confirm that your vehicle's alternator is charging the battery, and that the battery has ample charge. A low battery can hinder the winch's pulling capacity.

## Winch only rotates in one direction

The issue could stem from a malfunctioning winch remote, an electrical issue, or a defective solenoid.

- > Make sure that the remote is properly paired and connected.
- > Examine the motor control solenoid inside your Grenadier's front right fender. This component determines the winch motor's direction. Make sure the solenoid is working and its cable connections are secure.
- > Inspect the cable connections of the winch motor itself.
- > Assess the winch motor for any damage that might've occurred during a stall or any potential electrical issues.

## Winch will not spool in or out

- > Make sure the winch remote control is paired and connected to the winch's wireless receiver inside your Grenadier's control unit.
- > Make sure that the Freespool Lever is set to the disengaged position. It should be vertical and pushed against the cam's lowest point. If it isn't snug against the lowest point, slightly pull out the winch rope by hand to rotate the winch drum. This rotation will help the lever properly lock into place.

# WINCHES

---

- > Inspect to see if the winch rope is slipping on the drum. If it is, cease all actions and wait until the drum halts. Once it's safe, pull out the winch rope to the red indicator and then rewind with more tension on the rope.
- > Make sure there are no foreign objects obstructing the winch drum and that the winch rope isn't tightly caught on a part of your Grenadier.
- > Examine the winch motor for potential damage from a stall or any electrical issues.

## **Winch stops suddenly during winching**

- > Inspect the connections between the terminals of the 150A circuit isolator found in the engine compartment. This circuit isolator monitors the current usage over time. If the winch draws too much power, the isolator will activate, cutting off its power.
- > Turn off the winch and let your Grenadier run for five minutes. This gives the circuit isolator time to reset itself and lets your Grenadier's batteries recharge.

## **Winch will not freespool**

The winch may not function properly due to issues with the mounting plate, the winch rope bunching on one side of the drum, or damage to the drum's flange or internal gears.

- > Make sure the freespool lever can move freely and be disengaged.
- > Verify the freespool lever is in the "released" position, which is horizontal and resting against the highest section of the cam extrusion.
- > For the freespool function to work, the winch drum must be able to rotate. Test this by pulling on the winch rope to see if the drum turns.
- > Check for any objects obstructing the winch drum and confirm that the winch rope isn't tangled or pulled too tightly against your Grenadier. If the rope seems to bunch up or is challenging to pull out, engage the freespool lever, then extend the winch rope about six feet. After doing this, return the lever to the "released" position and continue to use the freespool function.
- > A damaged mounting plate can become misshapen, potentially causing the winch drum to jam. Make sure the mounting plate is in good condition and properly aligned.

## WINCHES

### Winch will not hold vehicle weight

This can be caused by worn friction material or if the Winch brake has overheated from an extended period of powering out the Winch Rope.

The winch will secure your Grenadier in place when winching on an incline, provided the stress applied to the winch and associated equipment does not exceed their respective load ratings.

If it does not, make sure the winch rope isn't slipping on the drum. If you notice it slipping, stop winching and wait until the drum stops. When it's safe, pull the rope out to the red marker and rewind it, applying more tension.

The Plasma Lock anchors the winch rope to the drum using tension and friction. It features two loops. The rope goes through the first loop, wraps around the lock body four times, and then enters the opposite loop. The provided image illustrates this setup, showing the rope through the first loop and wrapped once over the Plasma Lock.

The following image shows the Plasma Lock with the Winch Rope inserted through first loop (1) and then one wrap of the Winch Rope around the Winch Drum and over the Plasma Lock (2).

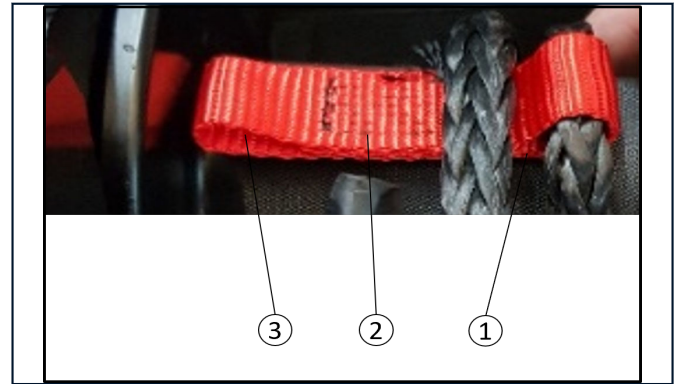

## WINCHES

The following image shows the Winch Rope tail inserted through second loop of the Plasma Lock (3) after passing over the Plasma Lock body four times.

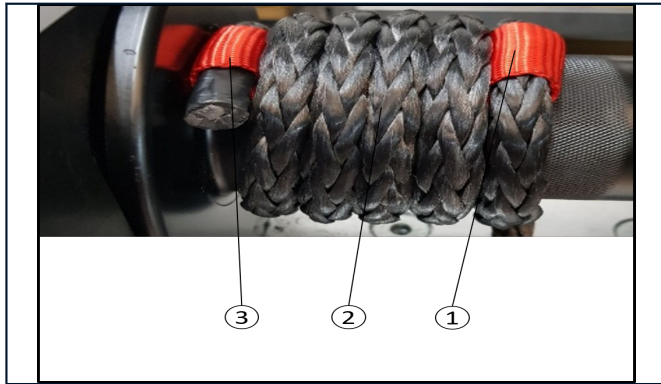

### If lowering your Grenadier down an incline:

- > Stop immediately if you spot the red marker on the winch rope from the driver's seat.

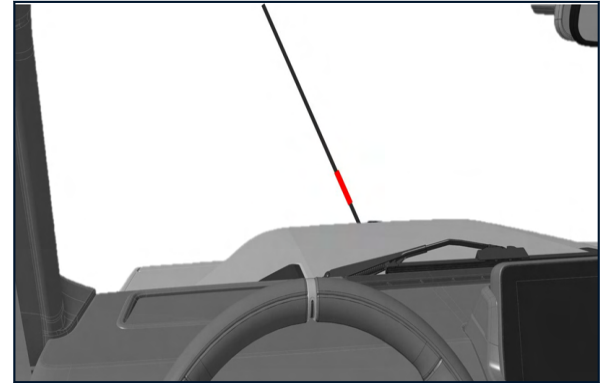

- > Also stop if you observe the Plasma Lock between the winch rope and drum.

Reaching these points means your winch rope is at maximum extension. Continuing might cause the frictional grip between the rope and drum to fail resulting in the Winch not being able to hold the vehicle weight.

## WINCH SERVICE AND MAINTENANCE

### Service intervals

The Front Integrated Heavy-Duty Winch and/or the Removable Rear Winch will require periodic servicing dependent on the frequency of use. Usage falls into three categories, Infrequent Use, Standard Use

# WINCHES

and Frequent Use. These categories are determined by how many hours of constant running time the Winch has undertaken.

- > INFREQUENT USE: If the Winch is used for less than 25 hours per year, then it should be serviced every 3 years.
- > STANDARD USE: If the Winch is used for between 25-50 hours per year (around 10 Winch pulls per week), then it should be serviced every 2 years.
- > FREQUENT USE: If the Winch is used for over 50 hours per year (around 20 Winch pulls per week), it should be serviced every year.



**WARNING: Failure to properly service your winch may result in serious injury and/or death to the operator and/or people nearby.**

## Servicing your winch

Do not pressure wash the winch. Pressure washing the winch can force water between the seals and gaskets. This may damage and disable the winch.

Check the battery regularly. Make sure that it is in good condition and is fully charged.

Check that all of the connections are clean and tight. Corrosion on the battery connections can affect the performance of the Winch. Make sure that the battery connections are tight.

The Winch is protected from water and rain, but avoid submerging the Winch for a prolonged time, particularly if the Winch casing is warm / hot.

If the Winch does become submerged, once clear, run the Winch in and out for about 30 feet (9 meters) of Winch Rope to generate heat inside the Winch, to help dry the inside of the casing.

Always inspect the full length of the Winch Rope before applying any load to it.

## WINCH LOAD LIMITS

Please refer to the following images for the Winch load limits:

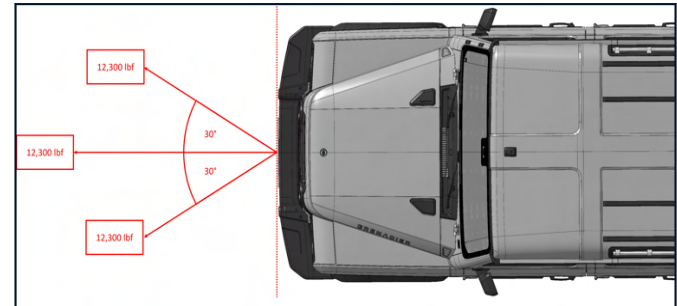

# WINCHES

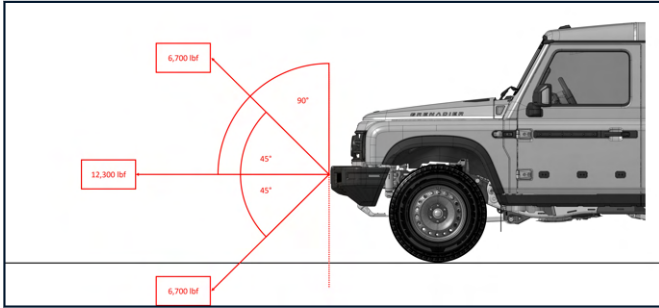

**WARNING:** Exceeding the load limits of your winch could result in an accident and in serious injury and death.



## MAINTENANCE REPAIRS AND TECHNICAL INFORMATION

---

CAPACITIES AND TECHNICAL INFORMATION .....	179
SERVICE AND MAINTENANCE .....	185
EXTERIOR CARE .....	204
INTERIOR CARE .....	207

## MAINTENANCE REPAIRS AND TECHNICAL INFORMATION

### CAPACITIES AND TECHNICAL INFORMATION

#### Mass and Load

##### Station Wagon:

Gross vehicle weight	7,716 lbs. (3,500 kg.)
Curb weight (without driver)	5,875 lbs. (2,664 kg.)
Maximum payload (without driver)	1,841 lbs. (835 kg.)
Dynamic roof load (with roof rack)*	330 lbs. (150 kg.)
Static roof load (with roof rack)*	925 lbs. (420 kg.)
Maximum un-braked trailer mass (on-road)	1,653 lbs. (750 kg.)
Maximum braked trailer mass (on-road)	7,716 lbs. (3,500 kg.)
Maximum trailer tongue weight	771 lbs. (350 kg.)**
Gross Combined Weight Rating (GCWR)	15,432 lbs. (7,000 kg.)

##### Quartermaster:

Gross vehicle weight	7,716 lbs. (3,500 kg.)
Curb weight (without driver)	5,875 lbs. (2,664 kg.)

Maximum payload (without driver)	1,841 lbs. (835 kg.)
Dynamic roof load (with roof rack)*	264 lbs. (119 kg.)
Static roof load (with roof rack)*	826 lbs. (374 kg.)
Maximum un-braked trailer mass (on-road)	1,653 lbs. (750 kg.)
Maximum braked trailer mass (on-road)	7,716 lbs. (3,500 kg.)
Maximum trailer tongue weight	771 lbs. (350 kg.)**
Gross Combined Weight Rating (GCWR)	15,432 lbs. (7,000 kg.)
Maximum Front Axle Load	3,675 lbs (1,667 kg.)
Maximum Rear Axle Load	4,739 lbs (2,150kg.)

\*Including weight of roof rack

\*\*Please refer to the plating on your Grenadier for the maximum tongue weight.

# MAINTENANCE REPAIRS AND TECHNICAL INFORMATION



## WARNING:

- > Except for unladen weight, the values above represent the absolute maximum load that your Grenadier can support. Never exceed those values. Exceeding those values may result in injury, serious injury, or death.
- > Read and follow the instructions in the Cargo Loading and Securing section.



*NOTE: Rear Axle Load information can be found on the door jamb, on both the Station Wagon and the Quartermaster.*

## Vehicle Dimensions

### Station Wagon:

Length (without spare wheel)	182.8 in. (4,643 mm.)
Length (including spare wheel)	191.2 in. (4,855 mm.)
Width with mirrors	84.5 in. (2,146 mm.)
Width with mirrors folded	76 in. (1,930 mm.)
Height (at curb weight)	80.7 in. (2,050 mm.)
Track Width	64.8 in. (1,645 mm.)
Front Overhang	33.4 in. (847 mm.)

Rear Overhang	34.4 in. (874 mm.)
Wheelbase	115 in. (2,922 mm.)
Approach Angle (at curb weight)	36.2°
Ramp Breakover Angle (at curb weight)	28.2°
Departure Angle (at curb weight)	36.1°
Ground Clearance (at curb weight)	10.4 in. (264 mm.)
Wading Depth	31.5 in. (800 mm.)
Wading Entrance Angle	16°
Wading Departure Angle	16°

### Quartermaster:

Length (including spare wheel)	212.6 in. (5,400 mm.)
Width with mirrors	84.5 in. (2,146 mm.)
Width with mirrors folded	76.5 in. (1,943 mm.)
Height (at curb weight)	79.5 in. (2,019 mm.)
Track Width	64.8 in. (1,645 mm.)
Front Overhang	33.4 in. (848 mm.)
Rear Overhang	52.3 in. (1,328 mm.)

## MAINTENANCE REPAIRS AND TECHNICAL INFORMATION

Wheelbase	127 in. (3,225 mm.)
Approach Angle (at curb weight)	36.2°
Ramp Breakover Angle (at curb weight)	26.2°
Departure Angle (at curb weight)	22.6°
Ground Clearance (at curb weight)	10.4 in. (264 mm.)
Gradeability	45°
Wading Depth	31.5 in. (800 mm.)
Front Axle Articulation	9°
Rear Axle Articulation	12°

### Volumes and Cargo Space

#### Station Wagon:

Maximum volume behind 1 <sup>st</sup> row seat	71.8 cu ft. (2,035 l.)
Maximum volume behind 2 <sup>nd</sup> row seat	40.6 cu ft. (1,152 l.)
Maximum cargo length behind 1 <sup>st</sup> row seat	64.7 in. (1,643 mm.)

Maximum cargo length behind 2 <sup>nd</sup> row seat	31.4 in. (797 mm.)
Floor length behind 1 <sup>st</sup> row seat	70.6 in. (1,793 mm.)
Floor length behind 2 <sup>nd</sup> row seat	38.7 in. (982 mm.)
Cargo space width (floor between wheel-arches)	41.8 in. (1,061 mm.)
Maximum cargo space width	49.9 in. (1,267 mm.)
Lift in height	35.3 in. (896 mm.)
Cargo space height	41.2 in. (1,046 mm.)

#### Quartermaster:

Cargo space width (floor between wheel-arches)	44.7 in. (1,135 mm.)
Maximum cargo space width	63.7 in. (1,617 mm.)
Lift in height	35.6 in. (904 mm.)
Quartermaster Box Floor Length	61.5 in. (1,562 mm.)
Quartermaster Box Height	19 in. (482 mm.)

### Tire Specifications

Your Grenadier comes with one of two tire options for each wheel size.

## MAINTENANCE REPAIRS AND TECHNICAL INFORMATION

MODEL	WHEEL DIAMETER	SERVICE TYPE	TIRE WIDTH	SIDEWALL HEIGHT	SPEED RATING	MAX LOAD (PER TIRE)
BF Goodrich All Terrain T/A KO2	17"	LT - Light truck carrying heavy load	265	70	S	3196 lbs. (1450 kg.)
BF Goodrich All Terrain T/A KO2	18"	LT - Light truck carrying heavy load	255	70	S	2832 lbs. (1285 kg.)
Bridgestone Dueler AT001	17"	PSR - Passenger Tires	265	70	S	2756 lbs. (1250 kg.)
Bridgestone Dueler AT001	18"	PSR - Passenger Tires	255	70	S	2756 lbs. (1250 kg.)

These tires are suitable for off-road and winter driving.

(including tread) will significantly degrade the performance of your Grenadier. Do not use replacement tires of different size, different specifications, or of lesser kind and quality. Failure to follow these instructions and precautions may result in serious injury and death.



**WARNING:** It is important that all of the tires on your Grenadier, including the spare, are replaced with tires that match the applicable specifications listed above for wheel size, duty, and load, and are of the same kind and quality. Tires that do not meet the required specifications and tires with inadequate qualities

### Tire pressures

TIRE DIMENSION	FRONT, REAR, SPARE	bar	kPa	PSI	PASSENGERS AND LOAD
LT 265/70/R17 S	FRONT	2,5	250	36	Max. 3 people
	REAR	2,5	250	36	
	SPARE	3,4	340	49	

## MAINTENANCE REPAIRS AND TECHNICAL INFORMATION

TIRE DIMENSION	FRONT, REAR, SPARE	bar	kPa	PSI	PASSENGERS AND LOAD
	FRONT	3,0	300	43.5	5 people plus luggage
	REAR	3,4	340	49	
	SPARE	3,4	340	49	
LT 255/70/R18 S	FRONT	2,5	250	36	Max. 3 people
	REAR	2,5	250	36	
	SPARE	3,4	340	49	
	FRONT	3,0	300	43.5	5 people plus luggage
	REAR	3,4	340	49	
	SPARE	3,4	340	49	

### Vehicle Identification and Engine Number

Your Grenadier Vehicle Identification Number (VIN) consists of seventeen characters. It can be found in the following locations; in the bottom left corner of the windshield in front of the driver, and on the chassis rail inside the right front wheel housing.

 Chassis Rail VIN location:

## MAINTENANCE REPAIRS AND TECHNICAL INFORMATION

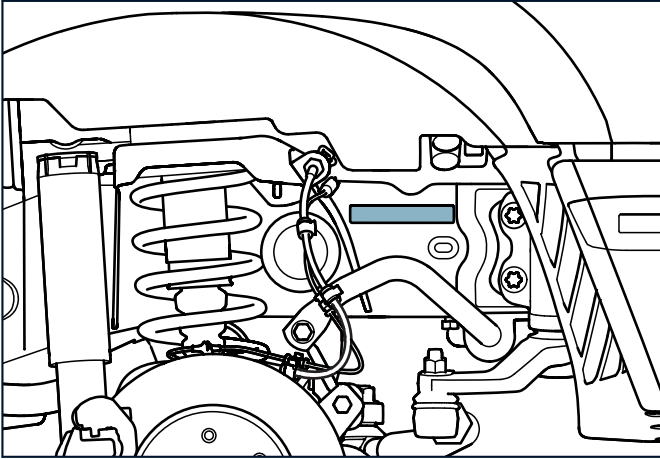

The engine is identified by a combined number found on the engine casing as shown below.

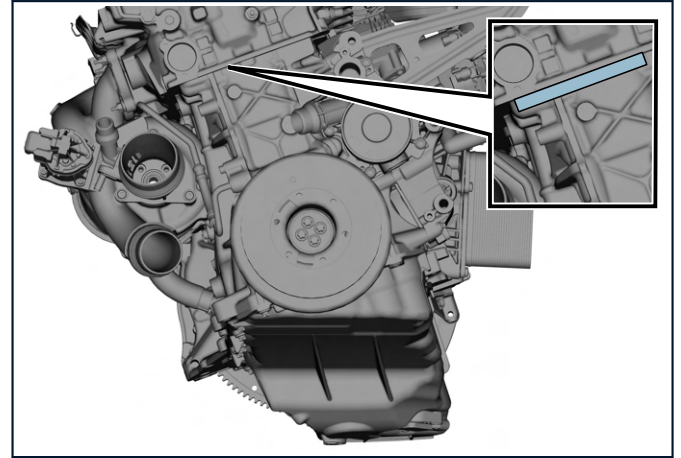

### Standard Audio System

There are four speakers inside your Grenadier, one located inside each door.

The minimum audio speaker output specification is 4x25 Watt true Root Mean Square (RMS). The speakers are rated individually at 4 Ohm.

# MAINTENANCE REPAIRS AND TECHNICAL INFORMATION

## Premium Sound System (if equipped)

The Premium Sound System provides a sub-woofer under the Rear Bench Seat

## SERVICE AND MAINTENANCE

### Maintenance Website

You must keep your Grenadier serviced and maintained. Follow the schedule provided to ensure your Grenadier will run reliably, smoothly, and efficiently. To see the service schedule, please scan the QR code below:



## Maintenance Schedule

Maintenance Information:

- > 12 MONTHS/12,000 MILES
- > 6,000 MILES IN HEAVY USE CASE
- > OIL SPECIFICATIONS:
  - SAE 0W-20, BMW LL17FE
  - 6.8 QT.
- > 1.5 SERVICE VISITS YEAR 1
  - +0.5 VISITS PER ANNUM
- > PDI = 2 HOURS
- > ACCESSORIES TO BE INSTALLED AT DEALER.

FUNCTION	12,000	24,000	36,000	48,000	60,000	72,000	84,000
Wiper Blades	IR	IR	IR	IR	IR	IR	IR



## MAINTENANCE REPAIRS AND TECHNICAL INFORMATION

FUNCTION	12,000	24,000	36,000	48,000	60,000	72,000	84,000
Air Filter		R		R		R	
Oil & Filter	R	R	R	R	R	R	R
Spark Plugs				R			
Axle Oil	R	A	A	A	A	A	A
Transmission Oil	A	A	A	A	A	A	R
Transfer Case Oil	A	A	A	A	R	A	A

A	Adjust Top Up
I	Inspect
R	Replace
IR	Inspect Replace

Various systems on this vehicle are very sophisticated and complex. Specialized knowledge, training, and equipment are necessary to carry out service and maintenance on those. Any servicing beyond what is described in this section must be performed at regular intervals by an INEOS dealer. Any maintenance that is not described in this section will need to be carried out by an INEOS dealer. If there is a malfunction with any of the systems included in this section, it is

advised your Grenadier is professionally inspected and repaired by an INEOS dealer.

### Emission Control

Your Grenadier is fitted with a variety of emissions equipment to meet specific market emission standards. Local laws may require inspections and servicing of types and frequencies.

Unauthorized replacement, modification or tampering with this equipment by an owner or repair shop may be unlawful and subject to legal penalties.

Engine settings must not be tampered with. These have been established to ensure that your vehicle complies with stringent exhaust emission regulations. Incorrect engine settings may adversely affect exhaust emissions, engine performance and fuel

# MAINTENANCE REPAIRS AND TECHNICAL INFORMATION

---

consumption, as well as causing high temperatures, which may result in damage to the catalytic converter and your Grenadier.

## Servicing and Maintenance Safety Precautions

Follow these safety precautions when performing simple, routine maintenance.

- > Keep children and bystanders away from your Grenadier, parts, and fluids.
- > Use only INEOS parts and INEOS recommended fluids. Other parts and fluids may harm your Grenadier and void your limited warranty.
- > If you must lift your Grenadier, use a proper lift designed for vehicle service. Avoid using the jack except in emergencies. If you must use the jack for anything other than changing a tire, be sure to use jack stands while working on your Grenadier. Follow the instructions and precautions in the Jacking subsection of the Driving On Road section.
- > Always wear protective clothing and equipment where possible to protect from dangerous (e.g., corrosive, hot) substances and parts.
- > Keep body parts and other objects (e.g., clothing, jewelry, hair) from moving parts (e.g., fans, belts, pulleys).
- > When possible, work should be carried out when the fluids, engine, exhaust and other parts are cold. Some parts (e.g., catalytic converters) radiate high temperatures even after the engine has been switched off.

- > Some fluids in your Grenadier are flammable and toxic. Some release dangerous fumes. If you are going to work with fluids, do so in a well-ventilated area. You must avoid flames and sparks.



**WARNING: Failure to follow these instructions and precautions may result in serious injury and death.**

## Engine Oils and Disposal Warnings

Observe all laws regarding the disposal of waste oil and toxic fluids. It is illegal to pollute drains, water courses or soil with toxic chemicals, such as, used engine oil. Always dispose of vehicle liquids and lubricants at authorized waste disposal sites or at garage and refill stations. It is illegal and wrong to pollute drains, water courses, or soil. Use authorized waste disposal facilities, including garages that accept used oil. If in doubt, contact your local authority for advice.

## Hood Release

To open the hood, pull the lever located in the drivers foot-well, twice, to release the hood latch. Open the hood and secure in place by using the hood stay. The hood stay can be placed in two locations, one for normal access and the second for service access.

To close the hood, lower the hood until it is nearly closed, then let it fall to close. If the hood does not shut, open it again and repeat with light hand pressure.

### Washer Fluid Level Check and Refill



#### WARNING:

- > Only fill the washer fluid reservoir when the engine is cool and switched off. Never attempt to refill the screen wash reservoir when the engine is hot.
- > Washer Fluid can be highly concentrated and can be extremely flammable. It could ignite if it comes into contact with hot materials such as the exhaust manifold or the engine block.
- > INEOS recommends that a suitable funnel is used to avoid spillage, however clean any spillage around the filler opening before starting the engine.
- > In the event of a fire in the engine compartment, close the hood immediately if possible and call the fire service from a safe distance. Do not retrieve property from your Grenadier. Do not allow anyone to attempt to retrieve property. Property is replaceable. Your health and safety are far more important than property.
- > The washer fluid mixture ratio is regulated by the U.S. EPA and many individual states; do not exceed the allowable washer fluid dilution ratio limits that apply. Follow the usage instructions on the washer fluid container.

The rear washer system uses the same reservoir as the front washer system. The reservoir is located inside the engine bay, inside the front, left hand side. Only use washer fluid to fill the reservoir. Using other fluids can result in damage to the washer fluid system and other parts of your Grenadier, such as, the wiper blades. If inappropriate washer fluids are used for a prolonged period of time, then damage and staining can occur to the paintwork and other plastic trims. Be sure to follow the information provided with the product and any instructions on the product before use. Local or state regulations may restrict the use of volatile organic compounds (VOCs), which are commonly used as antifreeze agents in windscreen washer fluid. A windscreen washer fluid with limited VOC content should be used only if it provides adequate freeze resistance for all regions and climates in which your Grenadier will be operated. To fill the washer fluid:

1. Remove the washer reservoir cap.
2. Position a clean suitable funnel into place.
3. Add the washer fluid.
4. Wipe any spillage.
5. Replace the cap until secure.

### Engine Oil Check and Change

The oil level in the engine is electronically monitored and will signal when the oil level is too low or too high. These are the signals:

## MAINTENANCE REPAIRS AND TECHNICAL INFORMATION

OIL LEVEL	VALUE SHOWN
Motor oil level at a minimum	MIN
Level 1	25 %
Level 2	50 %
Level 3	75 %
Motor oil level full	100 %
Motor oil level overfilled	SPILL
Motor oil level OK	OK
Service function active	FUNC

Avoid driving your Grenadier if the oil level is low. If the low oil warning system continues to alert the driver after topping up, there could be fault. Consult an INEOS dealer.

Running the engine with low or high oil levels can cause serious engine damage. Maintain oil levels between the minimum and maximum.

Failure to use engine oil that meets the required specification can lead to sludge and deposit buildup. That can damage and disable your engine. Using thicker than recommended engine oil can increase engine load and reduce overall fuel efficiency.

Avoid using oil additives; they can damage the engine.

Running your engine with too little or too much oil, using incorrect engine oil, and using oil additives may void your Grenadier's limited warranty.

### Engine Oil Specification

SAE 0W-20

BMW LL17FE

6.5L

### To add oil

- > Only use oil that meets these specifications: SAE 0W-20, ACEA C2, BMW LL-17 FE
- > Locate the oil cap in the engine bay.
- > Turn the cap counter-clockwise and remove it.
- > Add the INEOS approved engine oil.
- > Replace the cap and tighten clockwise, do this until there is a resistance and the cap is secured.
- > Now check the engine oil level again to ensure the correct level of oil is achieved.

### Engine Coolant Check and Refill

There are two reservoirs, the main coolant reservoir for high temperature components and the auxiliary reservoir for low temperature components.

## MAINTENANCE REPAIRS AND TECHNICAL INFORMATION

To add coolant:

- > Make sure that the reservoirs and coolant are cool. Do not remove the filler (pressure) cap until the coolant system has cooled down. Scalding coolant and steam can erupt if the cap is opened while the coolant is hot.
- > Remove the coolant cap by rotating anti-clockwise, until the cap is removed. To check the levels of fluid notice there is a low and maximum level indicator visible on the inside of the tank itself.
- > Add the correct coolant fluid to the reservoir until the level reaches the maximum marker. Do not overfill or underfill the reservoir.
- > Re-apply the coolant cap by rotating clockwise until tight. Do not Over tighten the cap as you can damage the thread on the bottle and the cap itself.

Both reservoirs work independently. However, if one is using more coolant than the other and needs topping up more frequently, this could be a sign of malfunction. Consult an INEOS dealer.

Do not use coolant additives can damage the coolant system. They can damage your Grenadier.

Using an additive or the wrong coolant may void your Grenadier's limited warranty.

### Brake Fluid

Your Grenadier monitors brake fluid levels. If they are too low or too high, a signal will appear on the Telltale Cluster. If that signal appears,

stop driving your Grenadier and adjust the fluid level. If the fluid levels are not too low or high, then you have another issue, and you must consult an INEOS dealer.

The brake fluid reservoir is located under the hood, near the firewall on the drivers side.

The reservoir has markings for minimum and maximum levels. The fluid level should be between the minimum and maximum markings, never below minimum or above maximum.

To add brake fluid:

- > Remove the Reservoir cap.
- > Fill brake fluid up to the maximum level.
- > Install the reservoir cap securely.

Brake fluid is corrosive and flammable. Dispose of it carefully in accordance with local law. Clean spills immediately and thoroughly with clean water and a clean damp cloth.

### Brake Pad Wear Indication

Your Grenadier monitors the depth of your brake pads. If a brake pad is seriously worn, a signal  will appear on the Telltale Cluster. If the signal is illuminated, stop driving and consult an INEOS dealer.

When you turn the ignition of your Grenadier to "on" or "run" the brake indicator lamp on the Telltale Cluster in front of the driver will briefly illuminate (no more than 6 seconds). If the brake indicator lamp remains illuminated and does not turn off, there is a fault in the brake system. Take your Grenadier to an authorized service center.

# MAINTENANCE REPAIRS AND TECHNICAL INFORMATION

---

## Wiper Blades and Arms

Check the condition of your window wiper blades periodically and if they are not wiping cleanly. Look for deposits and for frayed or damaged blades. If you find no deposits and the wipers don't wipe cleanly, replace them. If the problem persists, replace one or both arms.

Always use blades and arms of a kind and quality equal to your Grenadier's original parts.

Most auto parts stores will do this work for you at no charge. Your INEOS dealer can do this, too. If you choose to do it yourself:

- > Cover the windshield or rear window (if applicable) to prevent scratching and other damage.
- > Lift the wiper arm away from the glass, press the retaining clip and push the blade away from the arm. As you are pushing away from the arm, unhook the wiper blade.
- > Locate the new blade assembly on the arm, hook it to the swivel bracket, and push it to engage the locking clip.

## Headlight Units

The headlight units are sealed to give superior protection when driving in extreme conditions. Each headlight unit consists of a DRL, the headlight, and directional indicator signal lamps.

If a headlight unit malfunctions, there should be a warning signal on the Telltale Cluster.

If a headlight unit is damaged or obstructed, you should notice during your periodic inspections or while driving at night.

Have malfunctioning or damaged headlights addressed by an INEOS dealer.

## Battery or Batteries

Your Grenadier's has at least one battery. It may have a second auxiliary battery connected to your Grenadier's electrical system but isolated from the starter circuit. The Auxiliary Battery is a back-up to support the main battery and works on a trickle charge system. The Auxiliary Battery protects your Grenadier as it prevents a voltage drop when cranking the engine. The standard battery area is under the left rear seat and is reached by folding that seat base forward. Make sure not to obscure the seat belt buckles when repositioning the seat. Keep the battery securely in place and covered at all times to avoid electric shock and exposure to harmful fluids (e.g., sulfuric acid).

Each battery is 12v105Ah EFB H9 and maintenance-free. Each still requires checking by your INEOS dealer at regular service intervals.

Your Grenadier is fitted with an Intelligent Battery Sensor (IBS). This monitors battery voltage, current, and temperature. If the IBS detects a problem, a signal will appear on the Telltale Cluster. If a low battery warning message shows, start the engine and allow it to idle so that the battery can recharge, or connect a suitable battery charger or conditioner. Alternatively drive your Grenadier for at least thirty minutes to replenish the battery charge levels. It is recommended, that if the battery capacity reaches a critical point, you contact an INEOS dealer for a battery health check.

## MAINTENANCE REPAIRS AND TECHNICAL INFORMATION

INEOS recommends that you have the batteries inspected and replaced by an INEOS dealer rather than trying to do so yourself.

If you must replace or inspect the battery yourself:

- > Be careful. Wear protective clothing (e.g., gloves, safety glasses, arm coverings) when handling batteries. Wash hands even after wearing gloves. If you come into contact with battery fluid, wash the affected area with cold clear water for at least 15 minutes.
- > Never place metal objects on the battery or allow the positive terminal to contact your Grenadier body. That can cause sparks and short circuits, and may ignite gases.
- > Be cautious of static electricity. It can cause sparks that may ignite the flammable gas mixture inside the battery.
- > Keep the battery away from flames and sparks. Make sure the area is well-ventilated if you open a battery fluid well.
- > Never run the engine with the battery(s) disconnected. That may damage your Grenadier.
- > When lifting a battery, use a battery carrier or handle with gloved hands on opposite corners to prevent acid flow through vent caps.
- > Only replace the battery with one that has the same specifications and quality as your original INEOS battery. DO NOT USE an LFP (LiFePO4) battery as a replacement.
- > Carry over detachable parts from the battery being replaced to the new battery, such as vent hoses, elbow fittings or terminal covers.

- > Make sure the vent hose is always connected to the original opening on the battery.
- > Install any existing or supplied cell caps.
- > Make sure that detachable parts are reconnected in the same way before they were removed.
- > Take the battery to a dealer or to an authorized location (e.g., battery disposal center or seller) as required by local law. Any other disposal method is unlawful and dangerous to people and the environment.



**WARNING: Failure to follow these instructions and precautions may result in serious injury and death.**

### Auxiliary battery (if equipped)



**WARNING:**

- > If water enters the battery and fuse compartments, do not attempt to touch the components and seek further advice from your INEOS approved partner. Failure to do so may result in serious injury or death.
- > If the replacement of the batteries is not carried out in the correct sequence, then there is a risk of a short circuit and/or damage to the batteries and electrical parts and/or components.

## MAINTENANCE REPAIRS AND TECHNICAL INFORMATION

Follow these instructions closely to avoid damage to your Grenadier and the risk of injury:

- Disconnect the ground connection to the Battery Combiner.
- Remove the Negative (-) terminal on both the Start and Auxiliary Battery. Never allow contact between the Battery Cables and conductive metal parts, for example, your Grenadier body.
- Perform Service Work.
- Re-assemble in the opposite order.
- Check that there is no fault indication on the Battery Combiner LEDs.
- Never operate your Grenadier with only one of the batteries connected, as this can lead to contact with unprotected conductive metal parts. If there is an emergency situation requiring your Grenadier to be used with one battery only, then ensure the connector cables are insulated and secured away from conductive metal parts.

### 400W Power Inverter (if equipped)

The 400W Power Inverter converts DC power to AC power. It is required to power any AC using devices (e.g., phones, laptops) using the domestic outlets located in the passenger compartment and the cargo area (Station Wagon) or the Loadbay (Quartermaster). This is particularly useful when taking your Grenadier camping. The Power

Inverter is rated to output 400 Watts at its peak rate. Output may be reduced in extremely hot and cold conditions.

### Station Wagon:

Outlets are found at the rear of the center console and under a cover behind the left rear wheel housing in the cargo area just inside the 30 door.

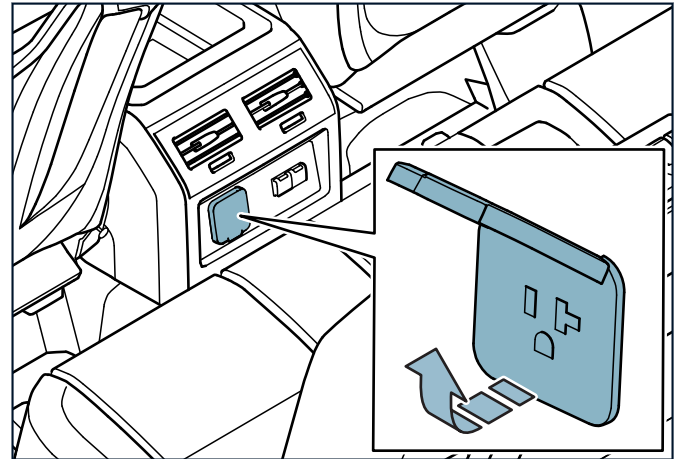



## MAINTENANCE REPAIRS AND TECHNICAL INFORMATION

Cargo area:

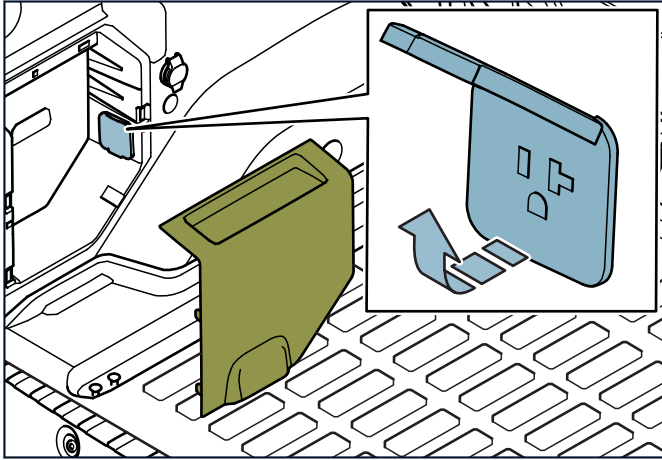

Quartermaster:

Outlets are found at the rear of the center console and under a cover inside the loadbay.

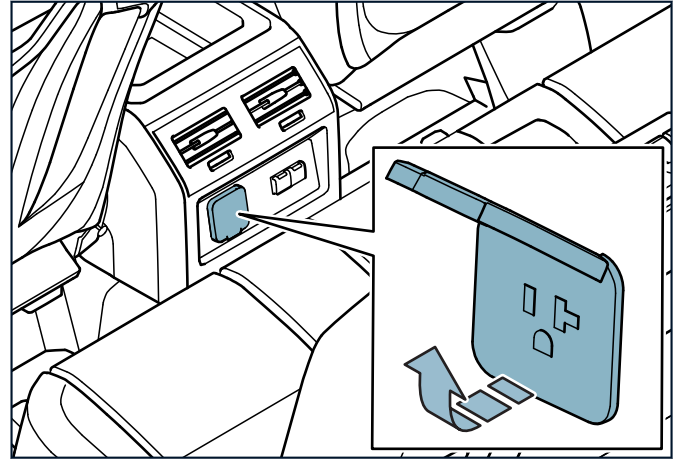

## MAINTENANCE REPAIRS AND TECHNICAL INFORMATION

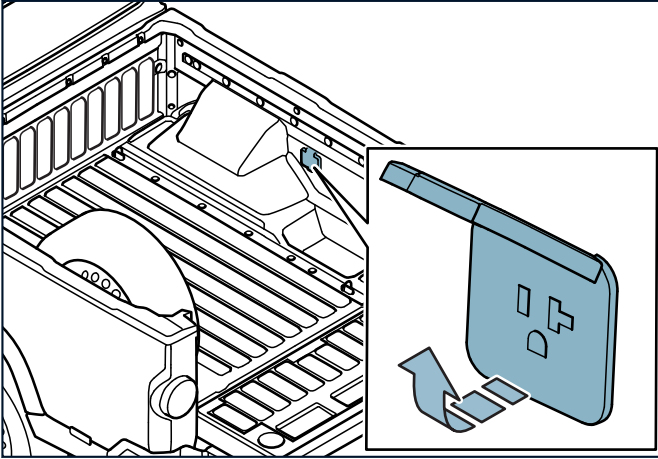

**i** *NOTE: Treat these outlets with the same care and respect with which you would treat outlets in a building. Do not alter them. Do not attempt to repair them.*

**i** *NOTE: When spraying water in and around the loadbay, only spray from the front of the cover. The cover may be forced open by water pressure, if sprayed from other angles.*

### Auxiliary switch panel and electrical preparation

Your Grenadier comes with three pre-wired 10 Amp electrical provisions, one each in the driver and front passenger foot-wells, and one in the engine compartment under the hood.

The interior 1 and 2 provisions (Switch 'INT 1' and 'INT 2' on the Overhead Control Panel), both terminate in the front left and right foot-wells respectively. They can be found behind the foot-well side trim piece and are wiring preparations consisting of a heat shrunk cable end, from which 3rd party devices can be powered.

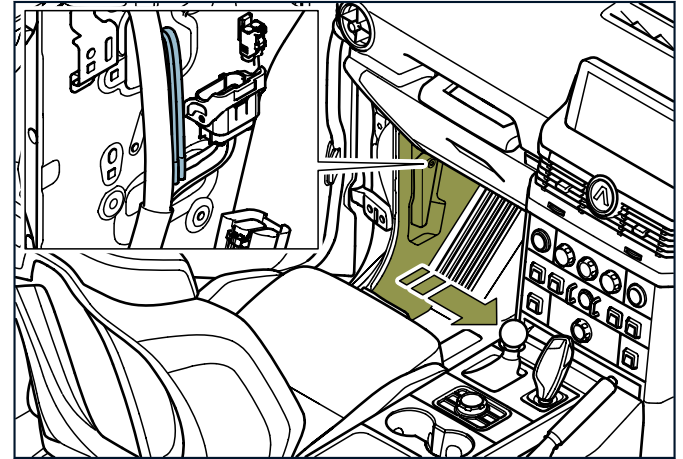

## MAINTENANCE REPAIRS AND TECHNICAL INFORMATION

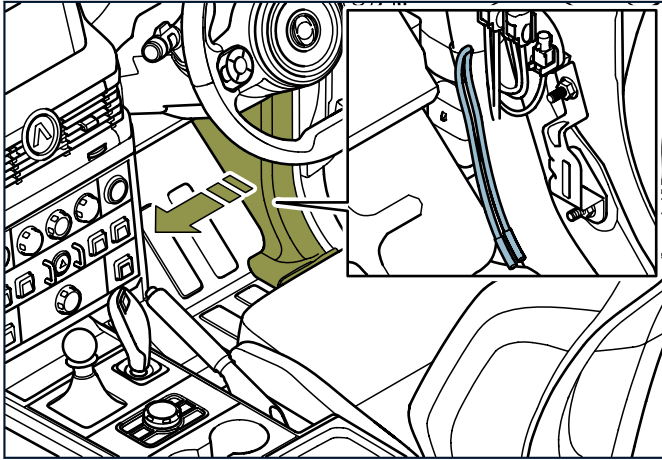

The EXT1 switch on the Overhead Control Panel controls the exterior wiring located under the hood.. This wiring setup includes cable ends that are heat-shrunk, allowing for the attachment of third-party devices.

### High load auxiliary switch panel and electrical preparation (if equipped)



#### WARNING:

- > The rear high amp outlet (NATO outlet) is intended for use with the Removable Rear Winch (Accessory) only. Do not connect any other

equipment to the rear high amp outlet (NATO outlet). Connecting equipment other than the Removable Rear Winch (Accessory) available through INEOS Automotive will be categorized as misuse and can result in serious injury and/or death.

- > INEOS Automotive will not be held responsible for any damages, injuries and/or deaths that occur from or relating to the operation of the rear high amp outlet (NATO outlet) outside of the intended purpose.
- > Do not remove any debris and/or mud from the rear high amp outlet (NATO outlet) until the power isolator has been switched off. Failure to do so can result in serious injury and/or death.
- > When connecting electrical accessories to the auxiliary outlets, ensure the connection is free of dirt, debris and moisture. Failure to do so will result in poor conductivity.
- > The rear high amp outlet (NATO outlet) cover may periodically need lubricating to prevent seizure. Care should be taken that the vehicle power is first turned off, before applying, and no grease residue is to be left on the contacts or connector body.

The High Load Auxiliary Switch Panel & Electrical Preparation comprises an extra 25A provision under the bonnet, a 500A provision (for the front winch if specified) and a 350A NATO outlet at

## MAINTENANCE REPAIRS AND TECHNICAL INFORMATION

the rear of your Grenadier (for the accessory winch, if specified). For the Station Wagon, there are four roof outlets, and for the Quartermaster, there are two roof outlets in the roof-rail recesses running on two 25A circuits.

### Station Wagon:

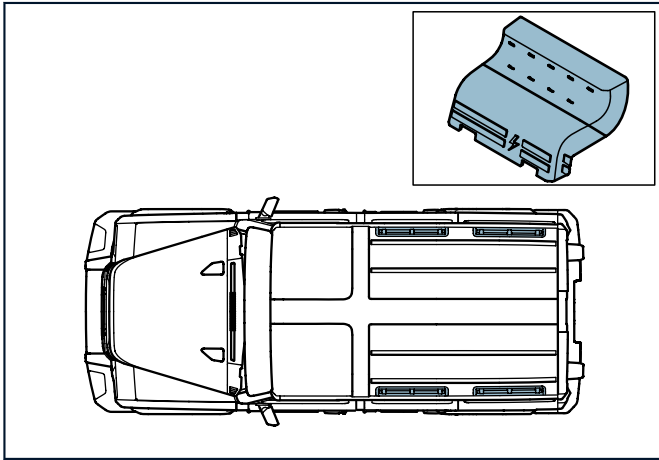

### Quartermaster:

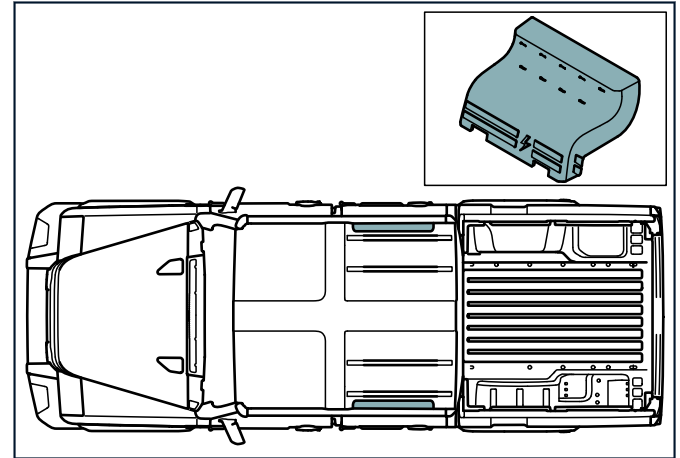

### Front 12V Socket

One 12V socket comes as standard in the front of your Grenadier, located in the Central Storage Box.

# MAINTENANCE REPAIRS AND TECHNICAL INFORMATION

## Auxiliary Charge Points

Additional USB A and USB C outlets are found at the rear of the center console. A secondary 12V socket can be found above the rear left wheel housing in the cargo area.

## Fuses

Fuses are installed to your Grenadier to prevent damage to electrical circuits. If too much current is supplied to a fused circuit, the fuse will blow, breaking the circuit. This reduces the risk of damage and accident.

Fuses are found in three locations: a panel under the Ignition Switch, in the engine compartment, and next to the main battery under the left rear seat.

If a fuse blows, the device to which it is connected will not work. Replace the fuse or have an INEOS dealer replace it for you. If the same fuse blows again, consult your INEOS dealer.

The following image and table show the locations, related system/device, and amp rating of the fuses inside the Cockpit Electrical Centre Fuse Box under the Ignition Switch.

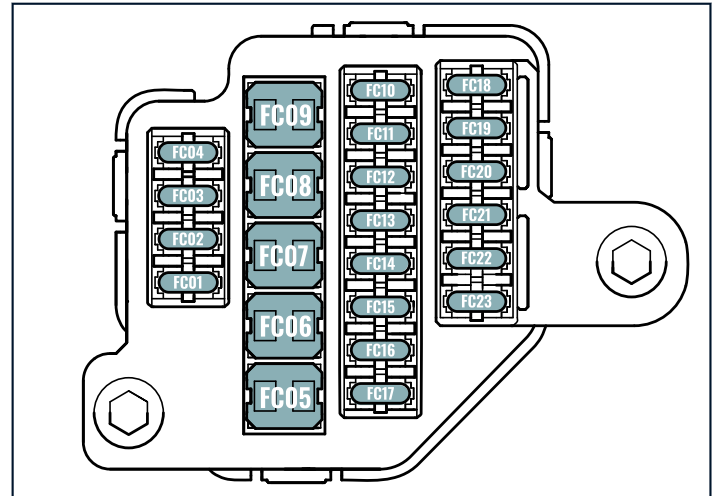

FUSE POSITION	DESCRIPTION	AMPERAGE
FC01	Gear Selector	5
FC02	Cluster / Glove Box / Steering Wheel	7.5

## MAINTENANCE REPAIRS AND TECHNICAL INFORMATION

---

FUSE POSITION	DESCRIPTION	AMPERAGE
FC03	HVAC Module	7.5
FC04	Clock / Theft Alarm / Logistics	5
FC05	Body Control Module 1	40
FC06	Body Control Module 2	30
FC07	Additional Heater Step 3	40
FC08	Additional Heater Step 2	40
FC09	Additional Heater Step 1	40
FC10	Reserved	FREE
FC11	HVAC Module	7.5
FC12	Head Unit	20
FC13	Emergency Call	5
FC14	Ignition Switch / Steering Wheel	10
FC15	On-board Diagnostics (OBD-II)	10
FC16	Reserved	FREE
FC17	Reserved	FREE
FC18	Reserved (Diagnostics)	FREE
FC19	Reserved	FREE

FUSE POSITION	DESCRIPTION	AMPERAGE
FC20	Reserved	FREE
FC21	12V Front Outlet	15
FC22	USB Charging	5
FC23	12V Rear Outlet	15

## MAINTENANCE REPAIRS AND TECHNICAL INFORMATION

The following image and table show the locations, related system/device, and amp rating of the fuses inside the Interior Electrical Centre Fuse Box under the left rear seat.

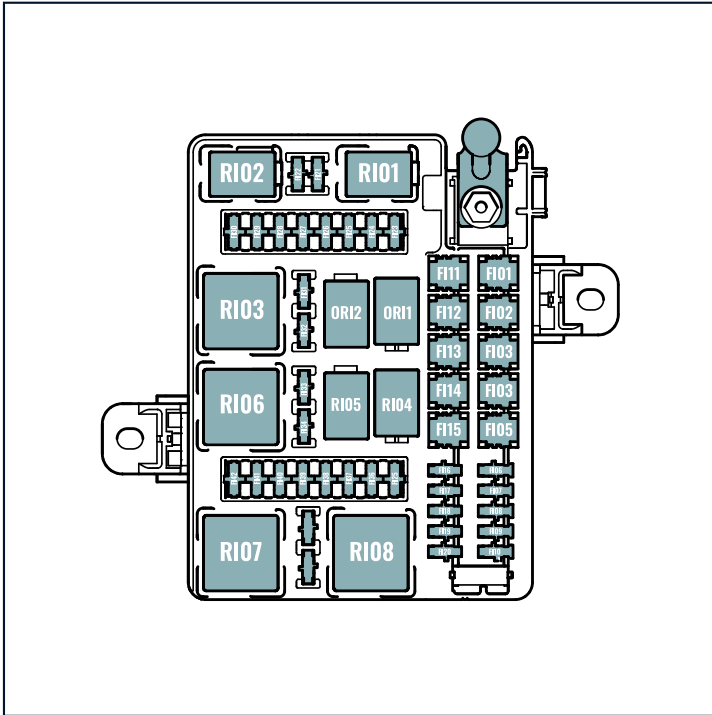

FUSE POSITION	DESCRIPTION	AMPERAGE
FI01	IGN Relay (CL15 - Electronics)	30
FI02	IGN Relay (CL15 - Pumps / Heating)	60
FI03	Front Wiper Motor	30
FI04	Accessory Relay (CL30ACC - R103)	60
FI05	Horn (BCM)	20
FI06	Window Lifter FL (BCM)	30
FI07	Window Lifter FR (BCM)	30
FI08	Window Lifter RL (BCM)	30
FI09	Window Lifter RR (BCM)	30
FI10	After Run Relay (CL30S - R102)	25
FI11	Rear Defog	30
FI12	HVAC (Blower)	40
FI13	Amplifier / Trailer Brake Provision	40
FI14	Trailer Module	40
FI15	SCR Module 1	30

## MAINTENANCE REPAIRS AND TECHNICAL INFORMATION

FUSE POSITION	DESCRIPTION	AMPERAGE
FI16	Gateway Module 1 (ETGW)	30
FI17	Water Separator	25
FI18	Fuel Pump	30
FI19	Gateway Module 2 (ETGW)	15
FI20	Door Lock	20
FI21	Seat Heating Right	25
FI22	Seat Heating Left	25
FI23	Cooling Fan / AC Compressor	5
FI24	Amplifier	20
FI25	Trailer Brake Provision	25
FI26	SCR Module 2	15
FI27	Brake Light Switch	5
FI28	Overhead Console Switch	10
FI29	LHS Foot-well	10
FI30	RHS Foot-well	10
FI31	Trailer	25
FI32	Heated Mirrors	7.5

FUSE POSITION	DESCRIPTION	AMPERAGE
FI33	Trunk Lamp / IBS / NVLD	5
FI34	Front Camera (ADAS)	5
FI35	Run Crank - Steering / ESC / Brake Fluid Sensor	7.5
FI36	Airbag Control Module	10
FI37	Run Crank - BCM / ETGW / Seat Mat / Park Assist / Rear View Camera	7.5
FI38	Power Mirrors	5
FI39	Headlamp Leveling	10
FI40	Run Crank - HVAC / Cluster / Steering	7.5
FI41	Fuel Pump Controller / Exhaust Flap / Water Separator	5
FI42	Front Wiper / Rear Wiper	15
FI43	Water Pump	10



## MAINTENANCE REPAIRS AND TECHNICAL INFORMATION

The following image and table show the locations, related system/device, and amp rating of the fuses inside the Under-hood Electrical Centre Fuse Box.

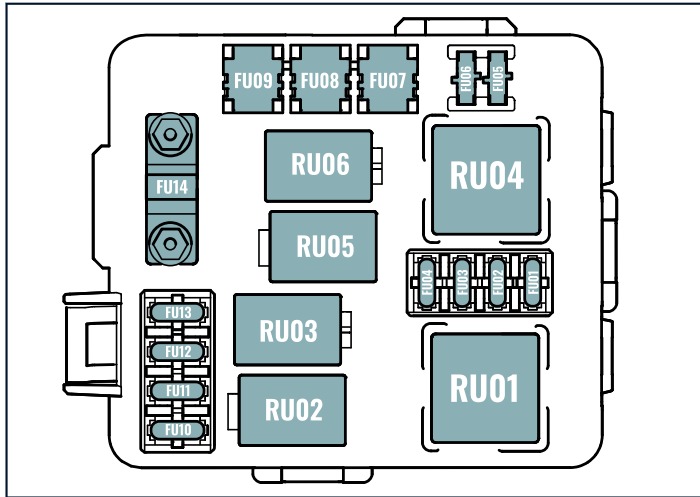

FUSE POSITION	DESCRIPTION	AMPERAGE
FU01	Reserved	Free
FU02	Transmission	20

FUSE POSITION	DESCRIPTION	AMPERAGE
FU03	Reserved	FREE
FU04	A/C Compressor	10
FU05	Gateway Module (ETGW)	5
FU06	Engine Cooling Fan	15
FU07	Electronic Stability Control (Valves)	40
FU08	Washer Pump	30
FU09	Starter Motor	30
FU10	Reserved	FREE
FU11	Reserved	FREE
FU12	Reserved	FREE
FU13	Horn - Toot	7.5
FU14	Electronic Stability Control (Motor)	60

The Amp rating of each fuse is signaled by a color to help identify the maximum current capacity of a fuse. The following table explains the fuse colors and the amp rating they signify.

## MAINTENANCE REPAIRS AND TECHNICAL INFORMATION

FUSE	CURRENT RATING
Black	1A
Grey	2A
Violet	3A
Pink	4A
Tan	5A
Brown	7.5A
Red	10A
Blue	15A
Yellow	20A
Clear	25A
Green	30A
Aqua Blue	35A
Orange	40A
Red	50A
Blue	60A
Tan	70A
Clear	80A

### Emissions Components

#### Gasoline particulate filter (GPF)

The GPF system is designed to reduce harmful gases and particulate emissions emitting from your Grenadier, through the exhaust system. Particulates over time will be burnt away at high temperatures, this is known as regeneration and happens automatically when driving your Grenadier.

Unlike a normal filter, which requires periodic replacement or regeneration, the GPF has been designed to operate at high temperatures to keep the GPF system from becoming blocked. The GPF will gather and burn harmful particulates while you are driving to avoid any harmful particulates being emitted by the exhaust system and entering the atmosphere.

Avoid prolonged idling and stop/start driving. Take your Grenadier for an occasional drive on a highway to allow the GPF to heat up to a high temperature to burn any particulates gathered. Driving your Grenadier only on short trips may not allow the GPF to get hot enough to burn particulates and prevent clogging.

For any suspected issues with the GPF system, contact your nearest INEOS dealer. Do not ignore or drive long distances, until the GPF system has been serviced or replaced.

#### Catalytic Converter

The catalytic converter is designed to reduce the number of harmful substances released into the atmosphere with the exhaust gases.

### CALIFORNIA PROPOSITION 65

 **WARNING:** Operating, servicing and maintaining a passenger vehicle or off-highway motor vehicle can expose you to chemicals including engine exhaust, carbon monoxide, phthalates, and lead, which are known to the State of California to cause cancer and birth defects or other reproductive harm. To minimize exposure, avoid breathing exhaust, do not idle the engine except as necessary, service your Grenadier in a well-ventilated area and wear gloves or wash your hands frequently when servicing your Grenadier. For more information go to [www.P65Warnings.ca.gov/passenger-vehicle](http://www.P65Warnings.ca.gov/passenger-vehicle).

 **WARNING:** Batteries, battery posts, terminals, and related accessories contain lead and lead compounds, and other chemicals known to the State of California to cause cancer and birth defects or other reproductive harm. Wash hands after handling.

 **WARNING:** This product can expose you to chemicals including cadmium, which is known to the State of California to cause birth defects or other reproductive harm. For more information go to [www.P65Warnings.ca.gov](http://www.P65Warnings.ca.gov).

# MAINTENANCE REPAIRS AND TECHNICAL INFORMATION

---

## EXTERIOR CARE

### Vehicle Washing

Do not use abrasive cleaners and brushes. They may scrape the paint. Use only high-quality automotive soap and wax.

Wash your Grenadier whenever it is dirty, after driving on treated (e.g., salted) roads in winter, after driving off-road, and after wading. Washing of the body, wheel wells, wheels and tires is essential for the preservation of your Grenadier.

It's best to wash your vehicle when it is not hot. Use cold or lukewarm water.

Avoid pressure washing. If you do pressure wash avoid window seals, door seals, and the ultrasonic sensors on the bumpers. Pressure washing can damage them.

After washing, drive your Grenadier for a short while to dry off the brakes. Wet brakes will be less effective at stopping the vehicle than dry ones so exercise caution.

Do not use household soaps or detergents, abrasive cleaners, scrapers, or solvents on any surface of your Grenadier. INEOS does not recommend you use a washing brush on your exterior to prevent scratching to paint and lenses.

#### Proper Washing Procedure:

- > Mix mild neutral detergent in a bucket of water, following the detergent manufacturer's instructions.
- > Prepare a second bucket with plain rinse water.

- > Use a clean wash mitt soaked in the detergent-water mix to wash your Grenadier. Wash in small sections, starting from the top and working your way down.
- > Rinse the wash mitt frequently in the plain rinse water to prevent mud and grit buildup, which can damage the paint.
- > For heavily soiled vehicles, hose down each section after washing to ensure all contaminants are removed.
- > Keep your Grenadier wet throughout the washing process, preventing detergent water from drying on the surface, which can cause staining and water marks.

#### Final Rinse and Drying:

Once washing is complete, rinse the entire vehicle thoroughly to ensure it's clean, with no dirty water trapped around the bodywork. Finish by drying your Grenadier with a soft drying towel before allowing it to air dry, preventing water spots from appearing on your Grenadier.

#### Cleaning Vehicle Windows After Washing:

1. **Window Cleaning:** After washing your vehicle, use a soft, lint-free cloth to wipe and clean the windows. Use a window cleaner specifically designed for vehicles but be sure to follow the manufacturer's instructions carefully.
2. **Avoid Abrasives and Scrapers:** Do not use abrasive cleaning compounds or scrapers on the windows.

# MAINTENANCE REPAIRS AND TECHNICAL INFORMATION

---

## Paint Work

Avoid putting stickers on painted surfaces. They may damage the paint.

Wax the paintwork after washings if you can. Use high quality non-abrasive wax and follow the manufacturer's instructions. Do not treat plastic trims and parts with polish or wax; this might discolor and damage them.

Modern water-based paints are more susceptible to contamination and marking by corrosive substances, however they are much safer and more environmentally friendly than solvent based paints. Clean the following from painted surfaces as soon as you can because these and similar substances can degrade your paint particularly in hot weather.

- > Bird droppings
- > Insect remains
- > Oil and Greases
- > Brake Fluid
- > Tree sap and pollen
- > Antifreeze
- > Resin
- > Tar
- > Salt

Minor paintwork damage such as minor stone chips can be touched up using a touch-up pen before rust forms and leads to corrosion. Any paint work repairs other than touching up small minor stone chips should be carried out by an INEOS dealer.

## Glass and Mirrors

Use glass cleaning fluid to clean these. Do not use abrasives or chemical solvents. Do not scrape any window except with a scraper designed for that purpose. Never scrape the inside of the rear window; you may damage the defrosting elements.

## Headlight Lenses

Clean the headlights using a soft cloth and mild soapy water. Do not use solvents, abrasives, or caustic agents. Do not clean the headlight lenses using a dry cloth or a scraper; they may scratch the lens.

## Under Hood Cleaning

Use an engine bay cleaner. Follow its instructions. Avoid damaging any plastics or metals. Do not use high pressure hoses or steam cleaners to clean the engine bay; they can infiltrate control modules and the fuse box and they can dislodge and damage parts.

## Under-ride Protection

Your Grenadier underbody has sacrificial protective panels to reduce the risk of damage to the radiator, fuel tank, and exhaust system. Consult your INEOS dealer for inspection and repair as necessary, especially after sustained off-road or wading use.

# MAINTENANCE REPAIRS AND TECHNICAL INFORMATION

---

## INTERIOR CARE

### Vacuuming

Be careful not to scratch upholstery, finishes, or controls. Use a soft brush whenever possible.

### Upholstery and Carpets

Use only a clean, damp cloth or a high quality cleaner designed for automotive upholstery and carpets, and follow the manufacturer's directions.

### Leather

Clean leather upholstery with a clean, damp cloth or use a high quality leather cleaner, following the manufacturer's directions.



*NOTE: Note that your limited warranty does not cover the Saddle Leather Driver's Pack. INEOS cannot accept responsibility for any staining, fading, discoloration or any other defects that are either typical of this leather type or that are caused by natural wear or other damage. By selecting the Saddle Leather Driver's Pack you acknowledge acceptance of the above information.*

### Controls

The steering wheel Central Display and Touchscreen, and other control surfaces should be cleaned only with a clean, damp cloth.

### Seat Belt Care

Use only a clean, damp cloth to clean seat belt hardware and webbing. Do not use household or automotive cleaning products; those can damage and weaken webbing material over time. Allow the belt to dry naturally while fully extended. Do not allow the belt to retract before it is fully dry, and do not dry with heat.

### Rinsing the Interior Floor

Your Grenadier has plugs that allow you to rinse the floor with water. Do not rinse any other part of the interior, and protect everything else (e.g., panels, switches, seats, seat belts) from splashes.



### WARNING:

There are air bag devices under both the front passenger and the front driver seat, and there are electrical devices under the rear seats. Do not let water contact any of these. Do not remove the splash guard under the rear seats. Water contact could result in a malfunction and lead to serious injury and death. If you accidentally let water get onto one of those devices, contact your INEOS dealer as soon as you can.

## MAINTENANCE REPAIRS AND TECHNICAL INFORMATION

### Before rinsing:

- Park your Grenadier on flat ground to ensure proper drainage.
- Turn the engine off.
- Remove the fire extinguisher (if equipped).
- Remove the tool kit.
- Remove floor mats (if equipped). (Do not rinse any area from which the mats cannot be removed.)
- Make sure the rear seat is not folded down.
- Remove the Expanded Polypropylene foam (EPP) blocks by loosening the two plastic retaining screws located above

each block. This releases tension to allow the trim to flex so you can remove the EPP foam block from beneath the trim.

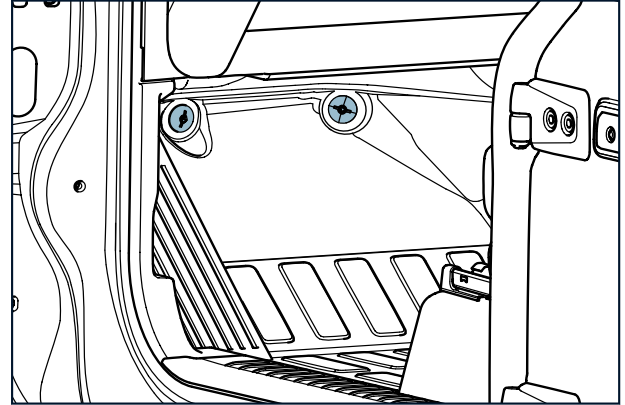

- Make sure the rear seats are in position (seat bases in place, backs upright) and that the rear splash guards are in place.
- Remove all footwell and cargo area mats.
- Remove all drainage plugs.
- Rinse one area (e.g., footwell, cargo area) at a time to ensure proper drainage.

## MAINTENANCE REPAIRS AND TECHNICAL INFORMATION

---

- > Use low pressure, low flow rate (approximately 4 cups/minute) water from a hose. Do not pour water from a bucket.
- > Direct puddling water to the nearest drainage hole and keep the holes clear.
- > Wipe the wet flooring with a clean drying towel.
- > Re-install drainage plugs.
- > Allow your Grenadier to dry out before closing the doors or windows and before driving.



# INEOS NEW VEHICLE LIMITED WARRANTIES

---

WARRANTY LIMITATIONS AND DISCLAIMERS .....	211
INTRODUCTION .....	212
WARRANTY COVERAGE AT A GLANCE .....	212
PROVISIONS APPLICABLE TO ALL INEOS LIMITED WARRANTIES .....	212
NEW VEHICLE LIMITED WARRANTY .....	215
FEDERAL EMISSION CONTROL WARRANTY .....	218
CALIFORNIA EMISSION CONTROL WARRANTY .....	221
MAINTENANCE .....	225

# INEOS NEW VEHICLE LIMITED WARRANTIES

---

## WARRANTY LIMITATIONS AND DISCLAIMERS

THE INEOS LIMITED WARRANTIES ARE THE ONLY EXPRESS WARRANTIES MADE IN CONNECTION WITH THE SALE OF THE COVERED VEHICLE. ANY IMPLIED WARRANTY, INCLUDING ANY WARRANTY OF MERCHANTABILITY OR WARRANTY OF FITNESS FOR A PARTICULAR PURPOSE IS LIMITED IN DURATION TO THE STATED PERIOD OF THESE WRITTEN WARRANTIES, EXCEPT IF THE DURATION OF IMPLIED WARRANTIES IS LIMITED BY STATE LAW, THE DURATION IS LIMITED TO THE LENGTH STATED IN THE WRITTEN WARRANTIES OR THE LENGTH STATED IN THE STATE LAW LIMITATIONS, WHICHEVER IS SHORTER. THERE ARE NO WARRANTIES WHICH EXTEND BEYOND THE FACE OF THIS DOCUMENT.

Some States do not allow limitations on how long an implied warranty lasts, so the above limitation may not apply to you.

THE INEOS LIMITED WARRANTIES DO NOT COVER ANY INCIDENTAL OR CONSEQUENTIAL DAMAGES, INCLUDING LOSS OF VALUE OF THE COVERED VEHICLE, LOST PROFITS OR EARNINGS, OUT-OF-POCKET EXPENSES FOR SUBSTITUTE TRANSPORTATION OR LODGING, EXPENSES ASSOCIATED WITH RETURNING THE COVERED VEHICLE TO AN AUTHORIZED SERVICE FACILITY OR DEALER, TOWING AND/OR ROADSIDE ASSISTANCE EXPENSES, EXPENSES ASSOCIATED WITH RETURNING THE COVERED VEHICLE BACK TO ITS OWNER, MECHANIC'S TRAVEL TIME OR COMMUNICATION CHARGES,

LOSS OR DAMAGE TO REAL OR PERSONAL PROPERTY, LOSS OR TIME, OR INCONVENIENCE.

Some States do not allow the exclusion or limitation of incidental or consequential damages, so the above limitation or exclusion may not apply to you.

THE INEOS LIMITED WARRANTIES ONLY COVER DEFECTS IN MATERIALS OR WORKMANSHIP AS DESCRIBED HEREIN. THE INEOS LIMITED WARRANTIES DO NOT COVER DEFECTS IN DESIGN.

NOTHING ELSE IN THE OWNERS MANUAL OR IN ANY OTHER STATEMENT—INCLUDING BUT NOT LIMITED TO ADVERTISING, PROMOTIONAL MATERIAL, VIDEOS, AND WEB PAGES—CONSTITUTES A WARRANTY BY INEOS AUTOMOTIVE AMERICAS, LLC.

YOUR ACCEPTANCE, OWNERSHIP AND USE OF YOUR COVERED VEHICLE CONSTITUTE ACCEPTANCES OF THE WARRANTY LIMITATIONS AND DISCLAIMERS AND OF THE LIMITATIONS OF WARRANTIES CONTAINED HEREIN. YOU MUST REVOKE YOUR ACCEPTANCE OF YOUR COVERED VEHICLE IMMEDIATELY IN ACCORDANCE WITH APPLICABLE STATE AND FEDERAL LAW IF YOU CHOOSE NOT TO ACCEPT THESE TERMS.

THESE WARRANTY LIMITATIONS AND DISCLAIMERS AND THE ENTIRE INEOS LIMITED WARRANTIES' SECTIONS SHALL BE INTERPRETED AND CONSTRUED IN ACCORDANCE WITH THE LAW OF NORTH CAROLINA, PRINCIPAL PLACE OF BUSINESS OF INEOS AUTOMOTIVE AMERICAS, LLC.

# INEOS NEW VEHICLE LIMITED WARRANTIES

## INTRODUCTION

INEOS Automotive Americas, LLC (“INEOS”) issues three limited warranties for the INEOS Grenadier subject to certain terms, conditions, and exclusions set forth in each of the following sections:

- > New Vehicle Limited Warranty;
- > Federal Emission Control Warranty; and
- > California Emission Control Warranty.

## WARRANTY COVERAGE AT A GLANCE

These charts summarize the INEOS Limited Warranties (as defined below) and their warranty periods or durations (for the date the warranty period or duration begins, please see the specific terms of the INEOS Limited Warranties).<sup>[1]</sup>

<sup>[1]</sup> For certain vehicles purchased in Kansas, the New Vehicle Limited Warranty may also provide an additional coverage period for seat belts. Please see the terms of the New Vehicle Limited Warranty for additional information.

### New Vehicle Limited Warranty:

Basic	60 months - 60,000 miles (Whichever comes first)
Paint	36 months - 60,000 miles (Whichever comes first)

Anti-perforation	12 years - Unlimited miles
------------------	----------------------------

### California Emission Control Warranty:

Performance	3 years - 50,000 miles (Whichever comes first)
Short-Term Defect	3 years - 50,000 miles (Whichever comes first)
Long-Term Defect	7 years / 70,000 miles (Whichever comes first)

### Federal Emission Control Warranty:

Defect	2 years - 24,000 miles (Whichever comes first)
Specific Parts	8 years - 80,000 miles (Whichever comes first)
Performance	2 years - 24,000 miles (Whichever comes first)

## PROVISIONS APPLICABLE TO ALL INEOS LIMITED WARRANTIES

In addition to the “Warranty Limitations and Disclaimers,” the following provisions are applicable to the New Vehicle Limited

# INEOS NEW VEHICLE LIMITED WARRANTIES

---

Warranty, the Federal Emissions Warranty, and the California Emissions Control Warranty.

## Who is the Warrantor and What are the Warranties?

INEOS Automotive Americas, LLC (“INEOS”) is the warrantor for the New Vehicle Limited Warranty, the Federal Emission Control Limited Warranty, and the California Emission Control Warranty (collectively, “INEOS Limited Warranties;” individually, an “INEOS Limited Warranty”).

## What Vehicle Does the INEOS Limited Warranties Cover?

The INEOS Limited Warranties apply to INEOS Grenadiers that are originally sold by an authorized INEOS Dealer in the United States and normally operated in the United States (“Covered Vehicle”). For the specific coverages under each of the INEOS Limited Warranties, please refer to the terms of the New Vehicle Limited Warranty, the Federal Emissions Warranty, or the California Emissions Control Warranty.

## Whom Do the INEOS Limited Warranties Cover?

The INEOS Limited Warranties cover the first retail purchaser of the Covered Vehicle and any subsequent owners until the conclusion of the applicable coverage period.

The original retail purchaser or subsequent transferee is responsible for conveying to the next owner the Owner’s Manual and all safety warnings, instructions, and the INEOS Limited Warranties if the Covered Vehicle is sold, loaned, or otherwise transferred to another person.

## When Do the INEOS Limited Warranties Begin?

The INEOS Limited Warranties begin on the original in-service date of the Covered Vehicle, which is the date the Covered Vehicle is delivered to the first retail purchaser (“In-Service Date”).

## When Do the INEOS Limited Warranties End?

The INEOS Limited Warranties run for the limited time specified in the INEOS Limited Warranties. Please see the specific terms of the applicable INEOS Limited Warranty for further details.

## What will INEOS Do Under the INEOS Limited Warranties?

INEOS will have all covered, warrantable defects in materials or workmanship repaired, replaced, or adjusted (at INEOS’s sole discretion), free of charge, by an INEOS Dealer. INEOS’s obligations, however, are subject to the conditions, limitations and exclusions set out herein.

## How Do I Obtain Warranty Service?

Whether you are in the United States or outside the United States, in order to obtain covered services under the INEOS Limited Warranties, please contact the authorized INEOS Dealer from which you purchased your Covered Vehicle or visit the website at [www.ineosgrenadier.com](http://www.ineosgrenadier.com) for additional details.

## What Other Limitations Apply to the INEOS Limited Warranties?

As also stated in the “Warranty Limitations and Disclaimers,” the following applies:

## INEOS NEW VEHICLE LIMITED WARRANTIES

---

THE INEOS LIMITED WARRANTIES ARE THE ONLY EXPRESS WARRANTIES MADE IN CONNECTION WITH THE SALE OF THE COVERED VEHICLE. ANY IMPLIED WARRANTY, INCLUDING ANY WARRANTY OF MERCHANTABILITY OR WARRANTY OF FITNESS FOR A PARTICULAR PURPOSE IS LIMITED IN DURATION TO THE STATED PERIOD OF THESE WRITTEN WARRANTIES, EXCEPT IF THE DURATION OF IMPLIED WARRANTIES IS LIMITED BY STATE LAW, THE DURATION IS LIMITED TO THE LENGTH STATED IN THE WRITTEN WARRANTIES OR THE LENGTH STATED IN THE STATE LAW LIMITATIONS, WHICHEVER IS SHORTER. THERE ARE NO WARRANTIES WHICH EXTEND BEYOND THE FACE OF THIS DOCUMENT.

Some States do not allow limitations on how long an implied warranty lasts, so the above limitation may not apply to you.

As also stated in the “Warranty Limitations and Disclaimers,” the following applies:

**THE INEOS LIMITED WARRANTIES DO NOT COVER ANY INCIDENTAL OR CONSEQUENTIAL DAMAGES, INCLUDING LOSS OF VALUE OF THE COVERED VEHICLE, LOST PROFITS OR EARNINGS, OUT-OF-POCKET EXPENSES FOR SUBSTITUTE TRANSPORTATION OR LODGING, EXPENSES ASSOCIATED WITH RETURNING THE COVERED VEHICLE TO AN AUTHORIZED SERVICE FACILITY OR DEALER, TOWING AND/OR ROADSIDE ASSISTANCE EXPENSES, EXPENSES ASSOCIATED WITH RETURNING THE COVERED VEHICLE BACK TO ITS OWNER, MECHANIC’S TRAVEL TIME OR COMMUNICATION CHARGES,**

**LOSS OR DAMAGE TO REAL OR PERSONAL PROPERTY, LOSS OR TIME, OR INCONVENIENCE.**

Some States do not allow the exclusion or limitation of incidental or consequential damages, so the above limitation or exclusion may not apply to you.

**As also stated in the “Warranty Limitations and Disclaimers,” the following apply:**

**THE INEOS LIMITED WARRANTIES ONLY COVER DEFECTS IN MATERIALS OR WORKMANSHIP AS DESCRIBED HEREIN. THE INEOS LIMITED WARRANTIES DO NOT COVER DEFECTS IN DESIGN.**

**NOTHING ELSE IN THE OWNER’S MANUAL OR IN ANY OTHER STATEMENT—INCLUDING BUT NOT LIMITED TO ADVERTISING, PROMOTIONAL MATERIAL, VIDEOS, AND WEB PAGES—CONSTITUTES A WARRANTY BY INEOS AUTOMOTIVE AMERICAS, LLC.**

**YOUR ACCEPTANCE, OWNERSHIP AND USE OF YOUR COVERED VEHICLE CONSTITUTE ACCEPTANCES OF THE WARRANTY LIMITATIONS AND DISCLAIMERS AND OF THE LIMITATIONS OF WARRANTIES CONTAINED HEREIN. YOU MUST REVOKE YOUR ACCEPTANCE OF YOUR COVERED VEHICLE IMMEDIATELY IN ACCORDANCE WITH APPLICABLE STATE AND FEDERAL LAW IF YOU CHOOSE NOT TO ACCEPT THESE TERMS.**

**THE WARRANTY LIMITATIONS AND DISCLAIMERS AND THE ENTIRE INEOS LIMITED WARRANTIES’ SECTIONS SHALL BE INTERPRETED AND CONSTRUED IN ACCORDANCE WITH THE LAW OF NORTH CAROLINA, PRINCIPAL PLACE OF BUSINESS OF INEOS AUTOMOTIVE AMERICAS, LLC.**

# INEOS NEW VEHICLE LIMITED WARRANTIES

---

The performance of necessary repairs and adjustments is the exclusive remedy under the INEOS Limited Warranties and any implied warranties. INEOS does not authorize any person or entity to create for it any other obligation or liability in connection with the Covered Vehicle.

INEOS reserves the right to change or improve the design of any Covered Vehicle or any other INEOS parts (collectively, "INEOS Products") at any time, without assuming any obligation to modify any INEOS Products previously manufactured or sold.

## **How do the INEOS Limited Warranties Relate to State Law?**

These warranties give you specific legal rights. You may also have other rights that vary from state to state.

## **NEW VEHICLE LIMITED WARRANTY**

In addition to the "Warranty Limitations and Disclaimers" and the "Provisions Applicable to All INEOS Limited Warranties," the below provisions are applicable to the New Vehicle Limited Warranty.

## **What is the Coverage Under this Limited Warranty and How Long?**

The New Vehicle Limited Warranty consists of the following coverages: Basic, Paint, Anti-Perforation, and Seat belt (Kansas only). Each are described further below.

### **Basic**

Basic coverage covers any repairs, replacements, or adjustments needed to correct defects in materials or workmanship for any

Covered Vehicle (other than Paint, Anti-Perforation, or Seatbelt, which are covered by separate terms discussed below).

The duration of the Basic Warranty is a period 60 months or 60,000 miles, whichever comes first, from the In-Service Date.

### **Paint**

Paint coverage covers any repairs, replacements, or adjustments needed to correct defects in materials or workmanship for original factory paint on any Covered Vehicle.

The duration of the Paint coverage is a period of 36 months or 60,000 miles, whichever comes first, from the In-Service Date.

### **Anti-Perforation**

Anti-Perforation coverage covers any repairs, replacements, or adjustments of the body sheet metal panels and the chassis frame on a Covered Vehicle to remediate inside-to-outside perforation from corrosion resulting from defective materials or workmanship.

The duration of the Anti-Perforation coverage is a period of 12 years (unlimited mileage) from the In-Service Date. The coverage, however, requires that the Covered Vehicle is inspected, and repaired, if necessary, annually by an INEOS Dealer.

### **Seat belt – KANSAS ONLY**

For only those Covered Vehicles purchased at retail in Kansas, the Seat belt coverage covers repairs, replacements, or adjustments needed to correct defects in materials or workmanship of any factory-installed seat belt in the Covered Vehicle.

# INEOS NEW VEHICLE LIMITED WARRANTIES

The duration of the Seat belt Warranty is a period of 10 years (unlimited mileage) from the In-Service Date.

## What is Not Covered by the New Vehicle Limited Warranty?

The New Vehicle Limited Warranty also does not cover the following:

1. Any non-genuine parts, accessories, or other equipment which are not approved by INEOS for use on the Covered Vehicle.
2. The tires equipped on the Covered Vehicle, which are subject to a separate warranty issued by the tire manufacturer. Please contact the tire manufacturer for more details.
3. Any consumables, parts and labor costs incurred as a result of, or in connection with, required or recommended maintenance service such as, but not restricted to, adjustments (including, but not limited to, wheel balancing and alignment, engine tune-up, headlight aiming), light bulbs (including LEDs), exhaust system and particulate filters, spark plugs, drive belts, clutch discs, brake discs/drums, brake shoes, brake pads, other filters, upholstery and trim, lost keys and fobs, wiper blades, brackets, clips and other fastenings, vehicle batteries (except where a failure is caused by failure of another part which is covered by the INEOS Limited Warranties), fluids or lubricants (unless replaced as part of a covered warranty repair and only then if the Covered Vehicle is not due to for a scheduled service).
4. Damage, malfunctions, failures, deterioration, or corrosion caused or resulting from:
  - > Misuse, accident, theft, arson or intentional damage;
  - > Racing, track days, off-road trials, or other competition or events;
  - > Industrial fall-out, acid or alkali contamination, stone chipping, chemical fall-out, tree sap, bird droppings, salt, hail, windstorm, lightning or other environmental conditions;
  - > Failure to follow proper maintenance services or use which is not in accordance with the relevant guidelines given in the Owner's Manual and the requirements set out under the section entitled "What are Your Responsibilities as a Customer?";
  - > Improperly performed maintenance services;
  - > Continuing use of the Covered Vehicle if a fault or problem has become open and obvious;
  - > Failure or unreasonable delay in having the Covered Vehicle repaired after a defect has become open and obvious;
  - > Modification or alteration of the Covered Vehicle or any parts fitted to it or improper repair;
  - > Repairs not performed by an INEOS Dealer; and

## INEOS NEW VEHICLE LIMITED WARRANTIES

---

- > Use of improper or contaminated fuels, fluids or lubricants; and
  - > Use of non-genuine parts, accessories, or other equipment which are not approved by INEOS for use on the Covered Vehicle
5. Normal deterioration of trim, paint, or other cosmetic items.
  6. Normal wear and tear, including noise, vibration, cosmetic conditions, and other deterioration attributable to such wear and tear.
  7. Any Covered Vehicle on which the odometer has been altered or replaced so that the reading does not correspond with the actual mileage of the Covered Vehicle.
  8. Any Covered Vehicle on which the Vehicle Identification Number ("VIN") and/or Engine Number have been altered or removed.
  9. Incidental or consequential damages.
  10. Any Covered Vehicle that has previously been involved in an incident that in INEOS's sole discretion rendered the Covered Vehicle as a total loss or which an insurer has previously decided was a total loss, because it was lost, stolen, destroyed or damaged beyond economic repair.
  11. Investigative/diagnostic work in connection with a fault which is not covered by this limited warranty.
  12. Paintwork, bumpers, grilles and other bright work (except where this is covered under the Paint coverage).
  13. Stripping or dismantling of the Covered Vehicle except as part of a valid warranty claim.
  14. Labor associated with the removal of any aftermarket accessories fitted to the vehicle in cases where access is restricted by the accessory and removal is required to replace a defective component in completing a warranty repair.

### What are Your Responsibilities as a Customer?

1. You must properly use, maintain, and care for the Covered Vehicle as provided in the Owner's Manual.
2. You should retain:
  - > All maintenance service records; and
  - > All documents and invoices relating to parts or accessory installation.



# INEOS NEW VEHICLE LIMITED WARRANTIES

3. As for the Paint and the Anti-Perforation coverages, you must:
- > Carefully read the vehicle care and maintenance instructions given in the Owner's Manual;
  - > Arrange for an INEOS Dealer to carry out the annual paint inspection and document it on the record confirming maintenance;
  - > Wash the Covered Vehicle regularly;
  - > Remove salt, sand, ice melting agents, road and oil tar, tree sap, bird droppings and other potentially harmful materials immediately when they are found on the Covered Vehicle; and
  - > Promptly repair any damage to the surface finish of the Covered Vehicle at your own expense.

## How Do I Obtain Warranty Service?

For information on how to obtain warranty service, see the section entitled "How Do I Obtain Warranty Service?"

## FEDERAL EMISSION CONTROL WARRANTY

In addition to the "Warranty Limitations and Disclaimers" and the "Provisions Applicable to All INEOS Limited Warranties," the below provisions are applicable to the Federal Emission Control Warranty.

Federal Emission Control Warranty

## What is Covered by this Warranty and for How Long?

There are two parts to this warranty: an Emission Defect Warranty and an Emission Performance Warranty.

### Emission Defect Warranty

INEOS warrants that your Covered Vehicle:

- > Was designed, built and equipped to conform at the time of sale with applicable federal emissions standards.
- > Is free from defects in materials and manufacturer's workmanship that may cause the vehicle to fail to meet these standards.

Federal regulations require that this warranty be in effect for two years or 24,000 miles from the In-Service Date, whichever occurs first. Additionally, components marked "(8/80)" in the COVERED PARTS LIST below have coverage of eight years or 80,000 miles from the In-Service Date, whichever occurs first.

### Emission Performance Warranty

Some states and localities have established vehicle inspection and maintenance ("I/M") programs to encourage proper vehicle maintenance. If an EPA-approved I/M program is in force in your area, you are eligible for Emission Performance Warranty coverage.

# INEOS NEW VEHICLE LIMITED WARRANTIES

Under the terms of the Emission Performance Warranty and federal regulations, INEOS will make all necessary repairs, through an INEOS Dealer, if both of the following occur:

- > Your Covered Vehicle fails to meet applicable emissions standards as determined by an EPA-approved emissions test.
- > This failure results or will result in some penalty to you — such as a fine or denial of the right to use your Covered Vehicle — under local, state or federal law.

This warranty is in effect for two years or 24,000 miles from the In-Service Date, whichever occurs first. Additionally, components marked “8/80” in the COVERED PARTS LIST below have coverage of eight years or 80,000 miles from the In-Service Date, whichever occurs first.

## **Covered Parts List**

- > Air/Fuel Metering System
  - Air/fuel ratio feedback control system
  - Cold-start enrichment system
  - Deceleration control system
  - Electronic fuel injection system components
    - Airflow sensor
    - Engine control module (8/80)
    - Throttle body

- Other components
- > Air Induction System
  - Intake manifold and intake air surge tank
- > Catalyst System
  - Catalytic converter and protector (8/80)
  - Constricted fuel filler neck
  - Exhaust manifold
  - Exhaust pipe (manifold to catalyst and/or catalyst to catalyst)
- > Evaporative Control System
  - Charcoal canister
  - Diaphragm valve
  - Fuel filler cap
  - Fuel tank
  - Vapor liquid separator
- > Exhaust Gas Recirculation (EGR) System
  - EGR gas temperature sensor
  - EGR valve
  - Associated parts

# INEOS NEW VEHICLE LIMITED WARRANTIES

- > Ignition System
  - Ignition coil and igniter
  - Ignition wires
  - Spark plugs
- > Positive Crankcase Ventilation (PCV) System
  - Oil filler cap
  - PCV valve or orifice
- > Other Parts Used in the Above Systems
  - Data link connector (8/80)
  - Hoses, clamps, fittings, tubing and mounting hardware
  - Malfunction indicator light and bulb (8/80)
  - Pulleys, belts and idlers
  - Sealing gaskets and devices
  - Sensors, solenoids, switches and valves

## What is Not Covered Under the Federal Emission Control Warranty?

The section entitled “What Other Limitations Apply to the INEOS Limited Warranties” and the section entitled “What is Not Covered by the INEOS Limited Warranties” also apply to the Federal Emission

Control Warranty. In addition, the Federal Emission Control Warranty obligations do not apply to failures or noncompliance caused by:

- > The use of replacement parts not certified in accordance with aftermarket parts certification regulations.
- > The use of replacement parts not equivalent in quality or design to original equipment parts.

## What are Your Responsibilities Under this Warranty?

### Maintenance

You are responsible for performance of the required maintenance indicated in the Owner’s Manual and the INEOS Limited Warranties. INEOS will not deny a warranty claim solely because you do not have records to show that you maintained your Covered Vehicle. However, any failure or noncompliance caused by lack of maintenance is not covered by this warranty.

When maintenance and repairs are paid for by you, these services may be performed by you or by any automotive service provider you choose. INEOS will not deny a warranty claim solely because you used a service provider other than an INEOS Dealer for maintenance and repairs. However, any failure or noncompliance caused by improper maintenance or repairs is not covered by this warranty.

### Replacement Parts

To ensure optimum performance and maintain the quality built into your Covered Vehicle’s emission control systems, INEOS recommends the use of INEOS Genuine Parts when servicing or repairing the systems.

# INEOS NEW VEHICLE LIMITED WARRANTIES

Warranty coverage is not dependent upon the use of any particular brand of replacement parts and you may elect to use parts that are not INEOS Genuine Parts for maintenance and repairs (note, any parts used in maintenance or repairs are not covered by the INEOS Limited Warranties). However, use of replacement parts that are not equivalent in quality to INEOS Genuine Parts may impair the effectiveness of the emission control systems.

If you use replacement parts that have maintenance or replacement schedules different from those of INEOS Genuine Parts, you must follow the maintenance and replacement schedules for the parts you are using. In addition, you should ensure that such parts are warranted by their manufacturers to be equivalent to INEOS Genuine Parts.

## What Do You Do If Your Covered Vehicle Fails an Emissions Test?

If your Covered Vehicle fails an EPA-approved emissions test, you may make a claim under the Emission Performance Warranty. To do so, take your Covered Vehicle to an INEOS Dealer and present a copy of the emissions test report. Also, take your maintenance records in case they are needed.

If your claim qualifies for coverage, the INEOS Dealer will repair your Covered Vehicle within 30 days (unless a shorter period is required by law). If your claim is denied, INEOS will notify you in writing of the reason within the same period. If we fail to do so, INEOS will repair your Covered Vehicle free of charge. The only exceptions allowed are when you request or agree to a delay, or when a delay is caused by factors beyond the control of INEOS or an INEOS Dealer.

If you require repairs under Emission Performance Warranty, and you are not within 100 miles of an eligible INEOS Dealer, INEOS may,

in certain circumstances, pay shipping costs to and from an eligible INEOS Dealer, have a service technician come to you, or pay for the repair to be made at an unapproved (*i.e.*, not approved by INEOS) service facility. For more details, please contact INEOS at the phone number or email address provided at [www.ineosgrenadier.com](http://www.ineosgrenadier.com).

## If You Have Questions

If you have questions or concerns about your Federal Emission Control Warranty coverage, please contact INEOS at the phone number or email address provided at [www.ineosgrenadier.com](http://www.ineosgrenadier.com).

### You may also request information from or report complaints to:

U.S. Environmental Protection Agency  
Vehicle Programs & Compliance Division  
(6405J)

Attn: Warranty Complaints  
401 M Street SW  
Washington, D.C. 20460

## CALIFORNIA EMISSION CONTROL WARRANTY

Vehicles equipped with a California Certified Emission Control System that are registered and operated in California or any state that adopts California emission warranty provisions are covered by this warranty. Currently, Colorado, Connecticut, Delaware, Maine,

# INEOS NEW VEHICLE LIMITED WARRANTIES

---

Maryland, Massachusetts, Minnesota, Nevada, New Jersey, New Mexico, New York, Oregon, Pennsylvania, Rhode Island, Vermont, Virginia and Washington are the other states to which this warranty applies. Vehicles covered by this warranty are also covered by the Federal Emission Control Warranty. In addition, the “Warranty Limitations and Disclaimers” and the “Provisions Applicable to All INEOS Limited Warranties” are applicable to this warranty.

## YOUR WARRANTY RIGHTS AND OBLIGATIONS

The California Air Resources Board (CARB) and INEOS are pleased to explain the emission control system warranty for your vehicle. In California, new motor vehicles must be designed, built and equipped to meet the State’s stringent anti-smog standards. INEOS must warrant the emission control system on your Covered Vehicle for the time periods listed below, provided there has been no abuse, neglect or improper maintenance of your vehicle.

Your emission control system may include parts such as the fuel injection system, ignition system, catalytic converter and engine computer. Also included may be hoses, belts, connectors and other emissions-related assemblies.

Where a warrantable condition exists, INEOS will repair, through an INEOS Dealer, your Covered Vehicle at no cost to you, including diagnosis, parts and labor.

## Manufacturer’s Warranty Coverage

For three years or 50,000 miles from the In-Service Date, whichever occurs first:

- > If your Covered Vehicle fails a Smog Check inspection, all necessary repairs and adjustments will be made by INEOS to ensure that your vehicle passes the test. This is your emission control system PERFORMANCE WARRANTY.
- > If an emissions-related part is defective, the part will be repaired or replaced by INEOS. This is your short-term emission control system DEFECTS WARRANTY.

For seven years or 70,000 miles from the In-Service Date, whichever occurs first:

- > If an emissions-related part listed below is defective, the part will be repaired or replaced by INEOS. This is your long-term emission control system DEFECTS WARRANTY.

## OWNER’S WARRANTY RESPONSIBILITIES

As the Covered Vehicle’s owner, you are responsible for performance of the required maintenance indicated in the Owner’s Manual. INEOS recommends that you retain all receipts covering maintenance on your Covered Vehicle, but INEOS cannot deny warranty coverage solely for the lack of receipts or your failure to ensure the performance of all scheduled maintenance.

You are responsible for presenting your Covered Vehicle to an INEOS Dealer as soon as a problem exists. The warranty repairs should be completed in a reasonable amount of time, not to exceed 30 days.

# INEOS NEW VEHICLE LIMITED WARRANTIES

As the Covered Vehicle's owner, you should also be aware that INEOS may deny you warranty coverage if your Covered Vehicle or a part has failed due to abuse, neglect, improper maintenance or unapproved modifications.

If you have any questions regarding your warranty rights and responsibilities, you should contact INEOS at the phone number or email provided at [www.ineosgrenadier.com](http://www.ineosgrenadier.com) or the California Air Resources Board, 9480 Telstar Avenue, Suite 4, El Monte, CA 91731, (800) 242-4450.

## WHAT IS NOT COVERED

The section entitled "What Other Limitations Apply to the INEOS Limited Warranties" and the section entitled "What is Not Covered by the INEOS Limited Warranties" also apply to the California Emission Control Warranty. In addition, these warranty obligations do not apply to failures or noncompliance caused by:

- > The use of replacement parts not certified in accordance with aftermarket parts certification regulations.
- > The use of replacement parts not equivalent in quality or design to original equipment parts.

## PARTS LIST: LONG-TERM EMISSION DEFECTS WARRANTY

The parts listed here are covered for seven years or 70,000 miles from the In-Service Date, whichever occurs first.

Air Induction/Exhaust System:

- > Cam Timing Control Motor
- > Camshaft Timing Gear

- > Intake Manifold
- > Throttle Body

Catalyst System:

- > Exhaust Front Pipe (including catalytic converter)
- > Exhaust Manifold (including manifold converter)

EGR System:

- > EGR Cooler
- > EGR Valve

Evaporative Control System:

- > Charcoal Canister
- > Fuel Tank
- > Fuel Tank to Canister Tube

Fuel Control System:

- > Engine Control Computer (Engine Control Module)
- > Fuel Pressure Sensor
- > Fuel Tube Sub-assembly
- > High-pressure Fuel Pump
- > Injector

# INEOS NEW VEHICLE LIMITED WARRANTIES

Transmission Control System:

- > Transmission Control Computer (Transmission Control Module)
- > Transmission Valve Body

Other Parts Used in Systems Listed:

- > Cooling Fan Motor with Controller

## MAINTENANCE

You are responsible for performance of the required maintenance indicated in the Owner's Manual and the INEOS Limited Warranties. INEOS will not deny a warranty claim solely because you do not have records to show that you maintained your Covered Vehicle. However, any failure or noncompliance caused by lack of maintenance is not covered by this warranty.

When maintenance and repairs are paid for by you, these services may be performed by you or by any automotive service provider you choose. INEOS will not deny a warranty claim solely because you used a service provider other than an INEOS Dealer for maintenance and repairs. However, any failure or noncompliance caused by improper maintenance or repairs is not covered by this warranty.

## REPLACEMENT PARTS

To ensure optimum performance and maintain the quality built into your Covered Vehicle's emission control systems, INEOS recommends the use of INEOS Genuine Parts when servicing or repairing the systems.

Warranty coverage is not dependent upon the use of any particular brand of replacement parts and you may elect to use parts that are not INEOS Genuine Parts for maintenance and repairs (note, any parts used in maintenance or repairs are not covered by the INEOS Limited Warranties). However, use of replacement parts that are not equivalent in quality to INEOS Genuine Parts may impair the effectiveness of the emission control systems.

If you use replacement parts that have maintenance or replacement schedules different from those of INEOS Genuine Parts, you must follow the maintenance and replacement schedules for the parts you are using. In addition, you should ensure that such parts are warranted by their manufacturers to be equivalent to INEOS Genuine Parts.

## IF YOUR VEHICLE FAILS A SMOG CHECK INSPECTION

If your Covered Vehicle fails a Smog Check Inspection, you may make a claim under the Emission Performance Warranty. To do so, take your Covered Vehicle to an INEOS Dealer and present a copy of the Smog Check Inspection report. Also, take your maintenance records in case they are needed.

If your claim qualifies for coverage, the INEOS Dealer will repair your vehicle within 30 days (unless a shorter period is required by law). If your claim is denied, INEOS will notify you in writing of the reason within the same period. If we fail to do so, we will repair your vehicle free of charge. The only exceptions allowed are when you request or agree to a delay, or when a delay is caused by factors beyond the control of INEOS or the dealership.

# INEOS NEW VEHICLE LIMITED WARRANTIES

---

For additional information on how to obtain service under the Emission Defects Warranty see the section entitled “How Do I Obtain Warranty Service?”

## EMERGENCY REPAIRS

In an emergency, where an INEOS Dealer is not reasonably available, warranty repairs may be made at any available service facility, or by the owner using any replacement part. A repair not being completed within 30 days also constitutes an emergency.

INEOS will reimburse you for your expenses, including diagnostic charges, for repairs covered by this Limited Warranty, for parts at INEOS's suggested retail price, and for labor at a geographically appropriate labor rate per INEOS's recommended warranty repair time allowances.

For reimbursement, however, you must present all replaced parts and a copy of your paid receipt to any INEOS Dealer. INEOS assumes no liability for the workmanship of any unapproved (*i.e.*, not approved by INEOS) service facility performing emergency repairs or any work performed by you or others in an emergency.

## MAINTENANCE

Please refer to the maintenance section in the Owner's Manual for additional details. The below is provided, however, as a summary.

## PERIODIC MAINTENANCE SERVICE

You should service the Covered Vehicle in accordance with INEOS's periodic servicing schedule and INEOS's recommended requirements, which are included in the Owner's Manual.

Maintenance need is based on a time or mileage/kilometers based schedule. You should arrange for maintenance when your Covered Vehicle reaches either the appropriate mileage or time interval. For example, for a 12,000 miles (20,000 kilometers) /12-month maintenance schedule, maintenance will be due when you've driven 12,000 miles (20,000 kilometers) OR the Covered Vehicle has been registered for one year, whichever occurs first.

INEOS recommends that Covered Vehicles be serviced within 1,000 miles (1,600 kilometers) or one month of the due time or distance.

## MAINTENANCE PROVIDER

When maintenance or repairs are paid for by you, these services may be performed by you or by any automotive service provider you choose. If you use a non-INEOS Dealer for maintenance, INEOS recommends you keep accurate records relating to the maintenance. INEOS also recommends all maintenance and repairs are only performed by suitably qualified persons as errors in maintenance may lead to damage to, or operational issues with, your Covered Vehicle.

## GENERAL MAINTENANCE

You should service the Covered Vehicle in accordance with INEOS's periodic servicing schedule and INEOS's recommended requirements, which are included in the Owner's Manual.



## INEOS NEW VEHICLE LIMITED WARRANTIES

---

Maintenance need is based on a time or mileage/kilometers based schedule. You should arrange for maintenance when your Covered Vehicle reaches either the appropriate mileage or time interval. For example, for a 12,000 miles (20,000 kilometers) / 12-month maintenance schedule, maintenance will be due when you've driven 12,000 miles (20,000 kilometers) OR the Covered Vehicle has been registered for one year, whichever occurs first.

INEOS recommends that Covered Vehicles be serviced within 1,000 miles (1,600 kilometers) or one month of the due time or distance.













































# INDEX

---

## 4

400W Power Inverter (if equipped) ..... 195

## A

A Brief Word About Tires ..... 56

Access Ladder (if equipped) ..... 99

Advance Driver Assistance Systems (ADAS) ..... 117

After Towing or Transport ..... 160

Air Bag - Additional Warnings ..... 92

Air Bag System Overview ..... 91

Air Bags ..... 89

Air Conditioning ..... 30

Air flow Zones ..... 30

Air flow zones - Recirculation ..... 30

Android Auto ..... 27

Anti-Lock Brake System (ABS) ..... 115

Anti-theft Immobilizer ..... 22

Apple CarPlay ..... 27

Automatic Car Washes ..... 137

Auxiliary Battery (if equipped) ..... 193

Auxiliary Charge Points ..... 198

Auxiliary switch panel and electrical preparation ..... 196

## B

Battery or Batteries ..... 192

Before Any Drive ..... 52

Before Wading ..... 149

Booster Seats ..... 87

Brake Fluid ..... 190

Brake Pad Wear Indication ..... 191

## C

California Emission Control Warranty ..... 222

California Proposition 65 ..... 18

Capacities and Technical Information ..... 179

Cargo Area (Station Wagon Only) ..... 96

Cargo Lamp (if equipped) ..... 45

Cargo Loading and Securing - Overview ..... 95

Catalytic Converter ..... 203

Center Control Panel ..... 30

Center Display and Touch Screen Notices ..... 27

Center Display and Touchscreen ..... 23

Center Display and Touchscreen - Audio ..... 25

Center Display and Touchscreen - Device ..... 25

Center Display and Touchscreen - Home ..... 25

Center Display and Touchscreen - Offroad ..... 25

Center Display and Touchscreen - Phone ..... 25

Center Display and Touchscreen - Settings ..... 26

Center Display and Touchscreen Warnings ..... 28

Central Control Interface (CCI) ..... 29

# INDEX

---

Child Door Locks .....	59
Children - Child Rear seating .....	81
Children - Forward-Facing Car Seat on the front seat .....	85
Children - LATCH (ISOFIX) - Lower Tethers .....	82
Children - Rear-Facing or Forward-Facing Car Seat with Seat belt .....	83
Children - Securing a Car Seat Upper Tether .....	84
Children - Securing your child into a Rear-Facing or Forward-Facing Car Seat .....	86
Children in Car Seats and Booster Seats .....	79
Children in Car Seats and Booster Seats Warnings	89
Child's Preference .....	87
Cleanliness .....	78
Compass with Altimeter (if equipped) .....	38
Connecting your phone or tablet .....	26
Coolant - Check and Refill .....	190
Cruise Control .....	115

## D

Data Recording .....	17
Daytime Running Lamps .....	38
Differentials - Front and rear axle differentials (if equipped) .....	145

Door Features and Functions - Touchscreen and Center Display .....	61
Door Latches .....	60
Door Warnings .....	62
Doors and Windows - Introduction .....	58
Downhill Assist .....	151
Driver Drowsiness Warning (DDW) .....	121
Driver Support Systems .....	114
Driving Controls .....	50
Driving On Road - Introduction .....	102

## E

Eco Start/Stop .....	110
Electrical Power On Without Starting the Engine .	102
Electronic Stability Control (ESC) .....	116
Emission Control .....	187
Emissions Components .....	203
Engine - Starting and Stopping the Engine .....	103
Engine - Turning the Engine Off .....	103
Engine and Powertrain Break-In .....	102
Engine Number .....	184
Engine Oil - Check and Change .....	189
Engine Oil Specification .....	189
Engine Oils and Disposal Warnings .....	187
Exterior Care .....	204

# INDEX

---

Exterior Utility Rails (if equipped) ..... 99

## F

Fan Speed Settings ..... 30

FCC notice ..... 23

Fire Extinguisher (if equipped) ..... 137

First Aid Kit ..... 136

Forward and Rear Lamps ..... 38

Forward Collision Warning (FCW) & Automatic

Emergency Braking (AEB) ..... 125

Front 12V Socket ..... 197

Front passenger classification system ..... 86

Fuel Economy ..... 56

Fuel Level and Range ..... 55

Fuel Tank Capacity ..... 54

Fuel Type ..... 54

Fuel Warnings ..... 56

Fueling ..... 53

Fueling at a Gas Pump ..... 55

Fueling Elsewhere ..... 56

Fuse Panels and Batteries ..... 50

Fuses ..... 203

## G

Gasoline particulate filter (GPF) ..... 203

Gear Range and Center Differential ..... 142

Gear selection ..... 127

Gear Selector ..... 107

General Warnings ..... 15

Glass and Mirrors ..... 206

## H

Hazard Signal ..... 43

Headlamp Auto Light Control ..... 39

Headlamp Controls ..... 39

Headlamp High Beam Flash ..... 40

Headlamp High Beams ..... 40

Headlamp Low Beams ..... 40

Headlamp Range Adjustment ..... 41

Headlight Lenses ..... 206

Headlight Units ..... 191

Heated Front Seats (if equipped) ..... 31

Heated Windscreen Washer Jets ..... 49

High load auxiliary switch panel and electrical

preparation (if equipped) ..... 197

Hood Release ..... 187

## I

Inspection-related Warnings ..... 53

Inspections ..... 52



# INDEX

---

Intelligent Speed Assist - Operation .....	120
Intelligent Speed Assist (ISA) - Overview .....	120
Interior Care .....	207
Interior Care - Controls .....	207
Interior Care - Leather .....	207
Interior Care - Seat Belt Care .....	207
Interior Care - Upholstery and Carpets .....	207
Interior Care - Vacuuming .....	207
Interior Lamps .....	45
Introduction - Features .....	14
Introduction and General Information .....	14

## *J*

Jacking .....	132
Jump Starting .....	136

## *K*

Key - Using your Key .....	22
Key battery replacement .....	23
Key-related Warnings .....	23
Keys .....	21
Keys - Introduction .....	21

## *L*

Lane Departure Warning (LDW) .....	123
------------------------------------	-----

LED Auxiliary Lights .....	44
LOADBAY UTILITY RAILS (IF EQUIPPED) .....	97

## *M*

Maintenance Schedule .....	186
Maintenance Website .....	185
Manual Shifting Mode .....	109
Mass and Load .....	180

## *N*

New Vehicle Limited Warranty .....	215
------------------------------------	-----

## *O*

Off-Road .....	139
Off-Road - Before Driving Off-Road .....	139
Off-Road Driving .....	142
Off-Road Mode .....	147
Other Controls .....	47
Overhead Control Panel .....	34
Overview - Introduction .....	20

## *P*

Paint Work .....	206
Park Assist .....	32
Parking Aid Systems .....	117

# INDEX

---

Parking Brake .....	104
Periodically and before long trips, trailering, and off-road driving .....	53
Powertrain .....	104, 142
Puddle Lamps .....	44

## Q

Quartermaster Loadbay Lamp & 12v Power Outlet (if equipped) .....	47
Quartermaster Tailgate Capacity .....	100

## R

Raised Air Intake Cyclone Pre-Cleaner (if equipped) .....	151
Raised Air Intake(if equipped) .....	151
Range and Locking Combinations .....	146
Rear Doors 30/70 .....	59
Rear Doors from the inside .....	60
Rear Doors from the outside .....	60
Rear Fog Lights .....	44
Rear Window Wiper (if equipped) .....	50
Rear Windows .....	63
Recovery .....	160
Replacement keys .....	22
Replacing a Tire .....	128

Reporting Safety Defects .....	17
Reverse Camera .....	110
Reverse Lights .....	44
Rinsing the Interior Floor .....	209
Roadside Emergencies .....	127
Rollover Warning .....	16
Roof Loading .....	98

## S

Safari Windows (if equipped) .....	64
Seat Belt - After a crash .....	78
Seat Belt - Introduction .....	74
Seat Belt - Release .....	76
Seat Belt - Warnings .....	79
Seat Belt - Wearing a Seat Belt .....	77
Seat Belt reminder .....	77
Seat Belts .....	74
Seat Belts - During a crash .....	78
Seat Heaters (if equipped) .....	73
Seatbelt - Putting on a Seat Belt .....	76
Seating - Adjusting a Front Seat .....	68
Seating - Folding a Rear Seat .....	71
Seating - Head Restraints .....	72
Seating - Warnings .....	74

# INDEX

---

Seats, Seat Belts, Children in Car Seats and Booster Seats, and Air Bags .....	66
Service and Maintenance .....	185
Servicing and Maintenance - Safety Precautions .	187
Side Doors .....	58
Side Doors - Operating from the inside .....	58
Side Doors - Operating from the outside .....	58
Side Marker Lamps .....	41
Side Windows .....	63
Sirius XM .....	27
Sitting Properly .....	67
Sleeping and moving children .....	88
Snow Chains .....	127
Sound - Premium Sound System (if equipped) ....	185
Sound - Standard Audio System .....	184
Spare Tire .....	129
Start / Stop .....	31
Steering Wheel Controls .....	38
Symbols in this Manual .....	15

## T

Telltale Cluster .....	37
Temperature and Auto Setting .....	30
Tire - Change a tire .....	134
Tire Emergencies .....	114

Tire Pressure Display .....	111
Tire Pressure Monitoring System (TPMS) .....	113
Tire pressures .....	183
Tire Specifications .....	182
Tires and Wheels - While Driving .....	110
Towing a Trailer .....	153
Towing Capacities .....	154
Towing with Four Wheels on the Ground .....	159
Traction Control .....	115
Trailer - Adjusting the Mirrors .....	154
Trailer - Connecting the Trailer .....	154
Trailer - Driving with a Trailer .....	155
Trailer - Parking with a Trailer .....	156
Trailer - Unhitching with the Trailer .....	156
Trailer and Hitch-Mounted Devices .....	98
Trailer and Load .....	154
Trailer Choice .....	153
Trailer Stability Assist .....	156
Transfer Case Selector .....	109, 143
Transmission Controls .....	104
Transporting Your GRENADIER .....	158
Turn Signals .....	42

## U

Under Hood Cleaning .....	206
---------------------------	-----

# INDEX

---

Under-ride Protection .....	207	Winch - Remote Control Pairing .....	168
Updates and Changes to this Manual .....	14	Winch - Service and Maintenance .....	175
Uphill Assist .....	151	Winch - Troubleshooting .....	171
<i>V</i>		Winches .....	162
Vehicle Dimensions .....	181	Winches - If you have two Winches .....	169
Vehicle Washing .....	205	Winches - Operating a Winch .....	171
Vent Adjustment .....	31	Winches - Remote Control Battery Replacement .....	167
VIN - Vehicle Identification Number .....	184	Winches - Removable Rear Winch (if equipped) ..	164
Volumes and Cargo Space .....	181	Window Defroster Front .....	30
<i>W</i>		Window Defroster Rear .....	30
Wading - Activating Wading Mode .....	150	Windows .....	62
Wading - After Wading .....	150	Windows - Introduction .....	62
Wading Mode .....	147	Windshield .....	62
Warning Triangle (if equipped) .....	137	Windshield Washers .....	49
Warranty - Emergency Repairs .....	225	Windshield Wipers .....	48
Warranty - Maintenance .....	225	Winter Driving .....	126
Warranty - Vehicle Fails A Smog Check Inspection ...	225	Wiper Blades and Arms .....	191
Warranty Coverage at a Glance .....	212		
Warranty Limitations and Disclaimers .....	211		
Washer Fluid Level .....	188		
Winch - Load Limits .....	177		
Winch - Remote Control .....	166		

**INEOS**  

---

**GRENA<sup>A</sup>DIER**