

RAISED AIR INTAKE CYCLONE PRE-CLEANER

Part Number: GRA-0B14-009860

Revised Date: 28th September 2023

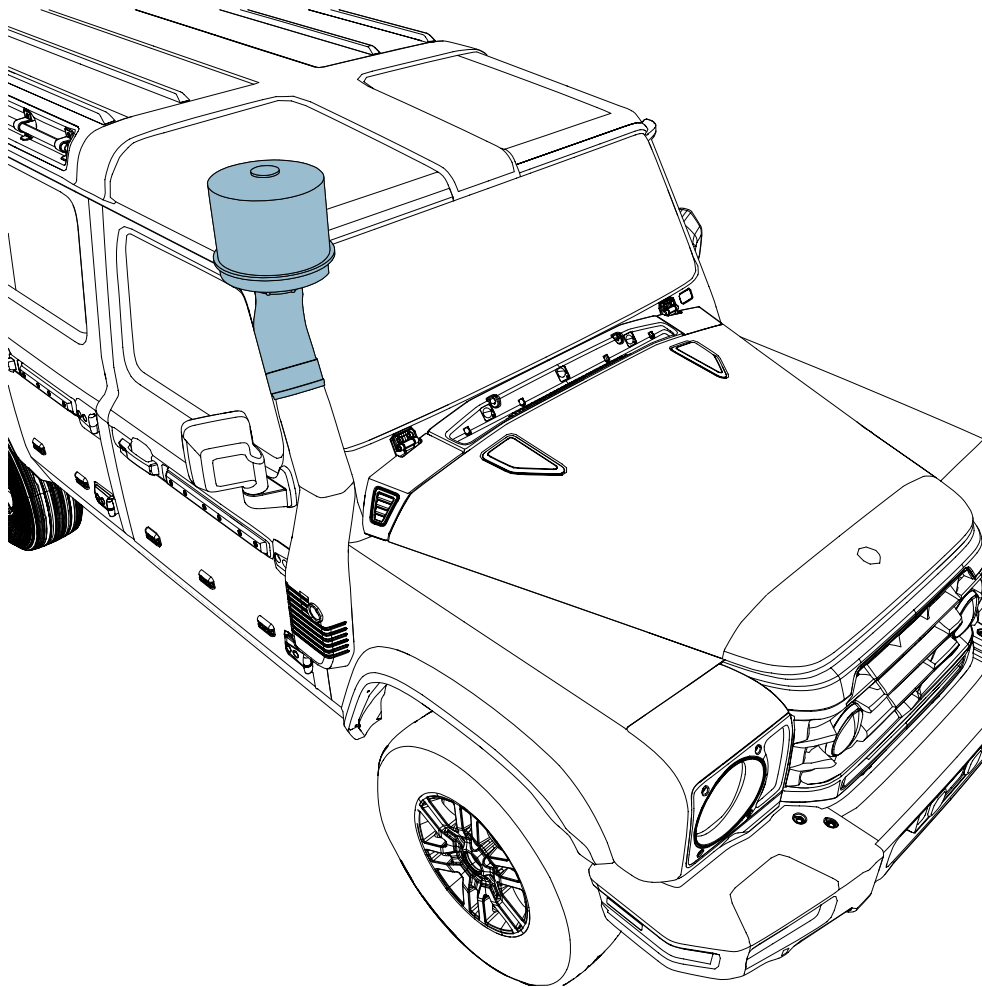

INTRODUCTION

This introduction is written for Grenadier owners and enthusiasts. It is designed to provide sufficiently detailed instructions to support those who enjoy the challenge of installing accessories to their Grenadier.

PAGE LAYOUT

Each instruction page is written in the same format:

- > The title of the fitting procedure.
- > The header table, which give technical information about the fitting procedure.
- > The parts table, which lists parts required for the task.
- > The supplies table, which lists supplies (such as oils, lubricants, adhesives) required for the task.
- > The procedure steps. Numbered and ordered, giving instructions and illustrations for each step.

WARNINGS, CAUTIONS AND NOTES

The following Warnings, Cautions and Notes are used within the repair steps:



Warning : A warning tells you that there is a risk of injury or death.



Caution : A caution tells you that there is a risk of damage to objects.



Note : A note tells you additional information that relates to the main topic.

ABBREVIATIONS

The following abbreviations are used within the Easy Repair Guide:

- > Special Service Tool (SST)
- > Manufacturer Specification Data Sheet (MSDS)

TECHNICAL QUALIFICATION

INEOS recommends that only persons who are technically competent should work on the vehicle. Work carried out by unqualified persons or using unapproved tools may result in damage to the vehicle or personal injury.

DISCLAIMER

This instruction was correct at the time of publishing. However, INEOS reserves the right to develop, improve and change any equipment, software, specifications, design, and/or information provided without notice or obligation. INEOS will not be held responsible for any inaccuracy or the consequences thereof.

©COPYRIGHT

© Copyright INEOS Automotive Limited, 2022. All Rights Reserved. These technical publications are provided for use by authorised users only. Under no circumstances should the content of any of the technical publications be reproduced, stored in a retrieval system or transmitted, in any form, electronic, mechanical, photocopying, recording or other means without prior written permission from INEOS Automotive Limited.

TABLE OF CONTENTS

Raised Air Cyclone Pre-Cleaner (Accessory Install)	4
Parts	4
Tools	5
Procedure	5

RAISED AIR INTAKE CYCLONE PRE-CLEANER (ACCESSORY INSTALL)

RAISED AIR CYCLONE PRE-CLEANER (ACCESSORY INSTALL)

Part Number	GRA-0B14-009860
Operation	Install
Model Year	Common
Repair Time	0.1 hour

PARTS

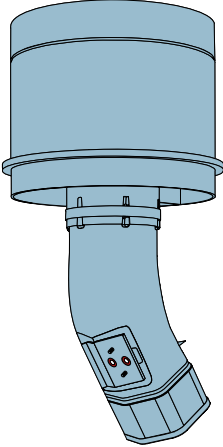
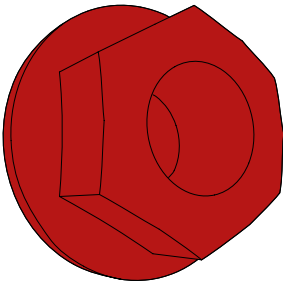
Part Number	Description	Image	Qty
GRA-0B14-009860	Raised Air Intake Cyclone		1
Part of Kit	Nut M6x1		2

RAISED AIR INTAKE CYCLONE PRE-CLEANER (ACCESSORY INSTALL)

TOOLS

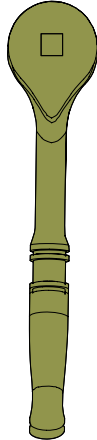
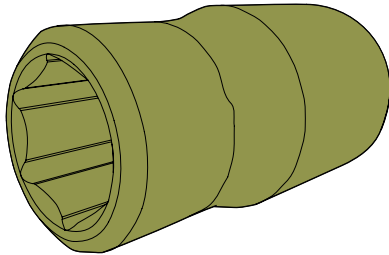
Part Number	Description	Image	Qty
Local Supply	1/4" Ratchet		1
Local Supply	1/4" Socket 6mm		1

PROCEDURE

Remove

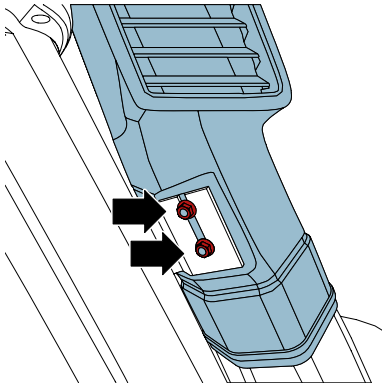
1	<p> <i>Note: The Raised Air Cyclone Pre-Cleaner is for off-road use only.</i></p> <p>Remove the two nuts that attach the Standard Raised Air Intake to the Top Bracket.</p> 
---	---

RAISED AIR INTAKE CYCLONE PRE-CLEANER (ACCESSORY INSTALL)

2

Remove the Standard Raised Air Intake.

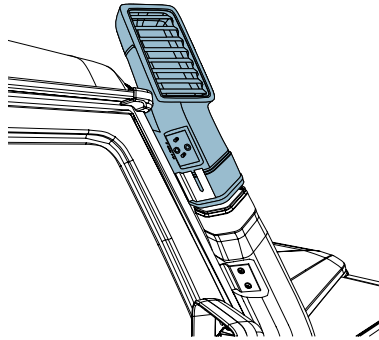

Install

3

Install the Cyclone Adapter to the Raised Air Intake Base.

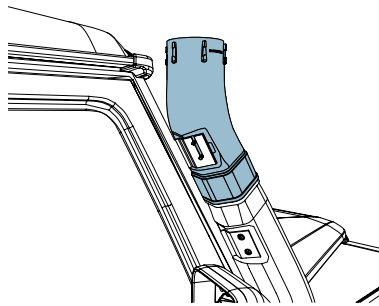

4

Install and torque the two nuts that attach the Cyclone Adapter to the Top Bracket to **10 Nm**

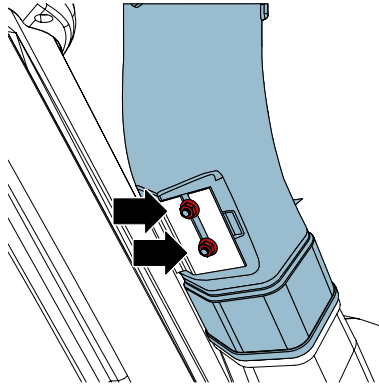

5



Note: Make sure the Cyclone Filter is fully engaged to the Cyclone Adapter.

Install the Cyclone Filter.

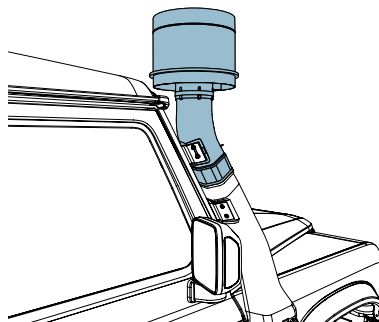

RAISED AIR INTAKE CYCLONE PRE-CLEANER (ACCESSORY INSTALL)

6

Install and tighten the Clamp to the Cyclone Filter.

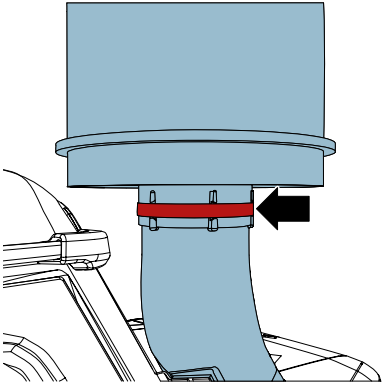

INEOS

GRENA^ADIER