

**INEOS**  

---

**GRENADIER**

**OWNER'S MANUAL**





## Welcome to your Grenadier

You're now not only the owner of a 4x4 with a story like no other. You're one of a group of like-minded individuals playing your part in the Grenadier's journey.

What began in 2016 as founder Jim Ratcliffe's vision to create a truly robust, reliable and ready-to-work 4x4 is now a reality. Fulfilling that idea and building the vehicle you're driving today has been a huge team effort, with our people, our partners and now drivers like yourself rising to every challenge.

This guide is intended to help you familiarise yourself with, and get the most from, your Grenadier. But there's nothing as instructive as getting out there and driving it. That's where your Grenadier's build quality and off-road capabilities will speak for themselves.

In short, shiny and new as it is, there's no need to treat your Grenadier delicately. It was conceived, designed and built on purpose. It's time to put it to yours.



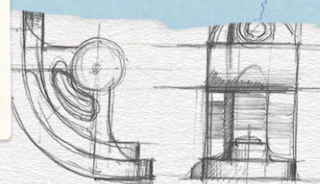
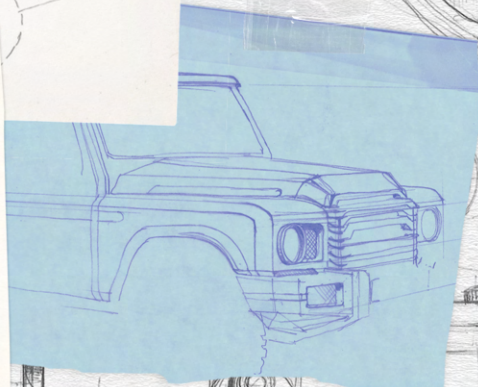
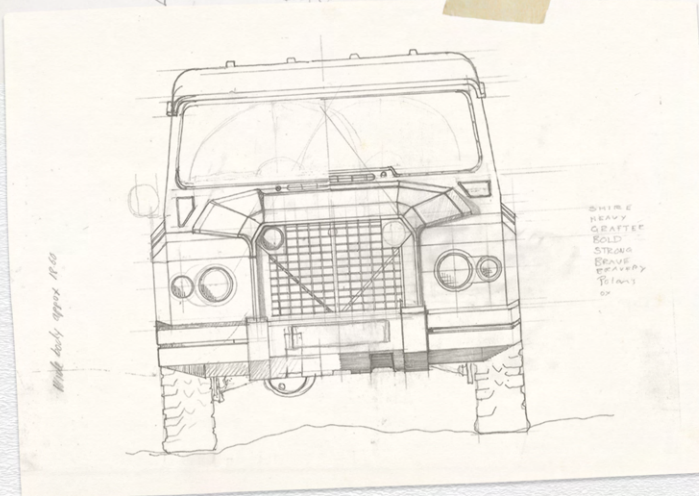
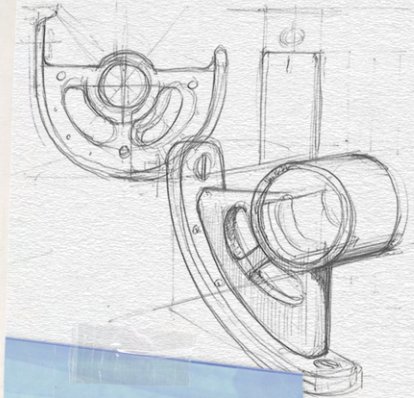
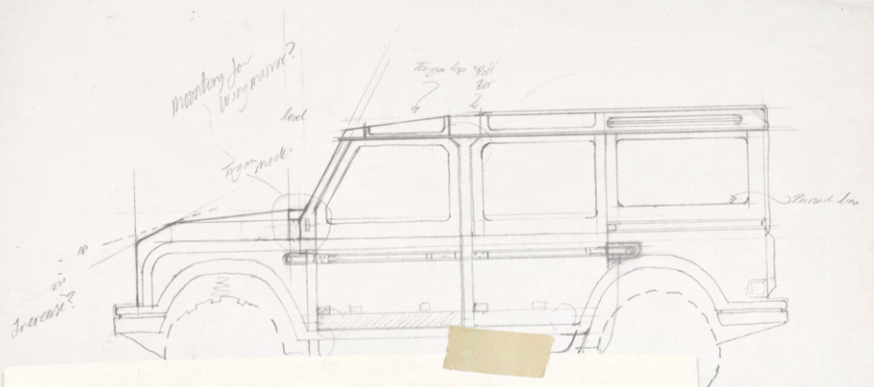

With body approx 1100

"It's not a very complicated vehicle - the boxy design is a result of a wheel in each corner, a ladder frame, then an engine of a certain size, which needs a certain number of radiators and cooling and space for crashing."

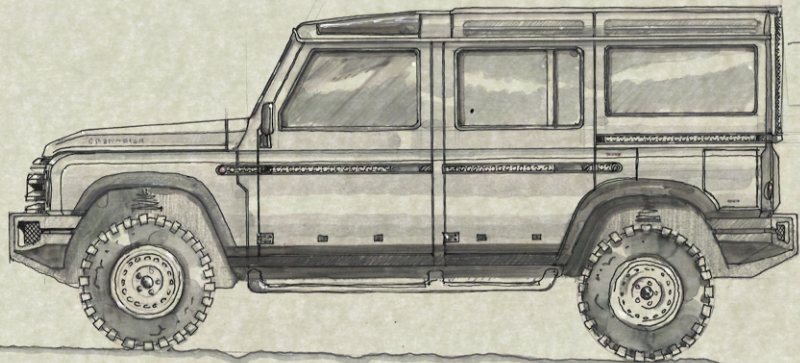

"We like the idea that it grows with you  
- it's made of beautiful saddle leathers,  
that will mature with time and gain  
a patina. It becomes very personal to the  
people that are driving it all the time.  
It's a living element of the vehicle."

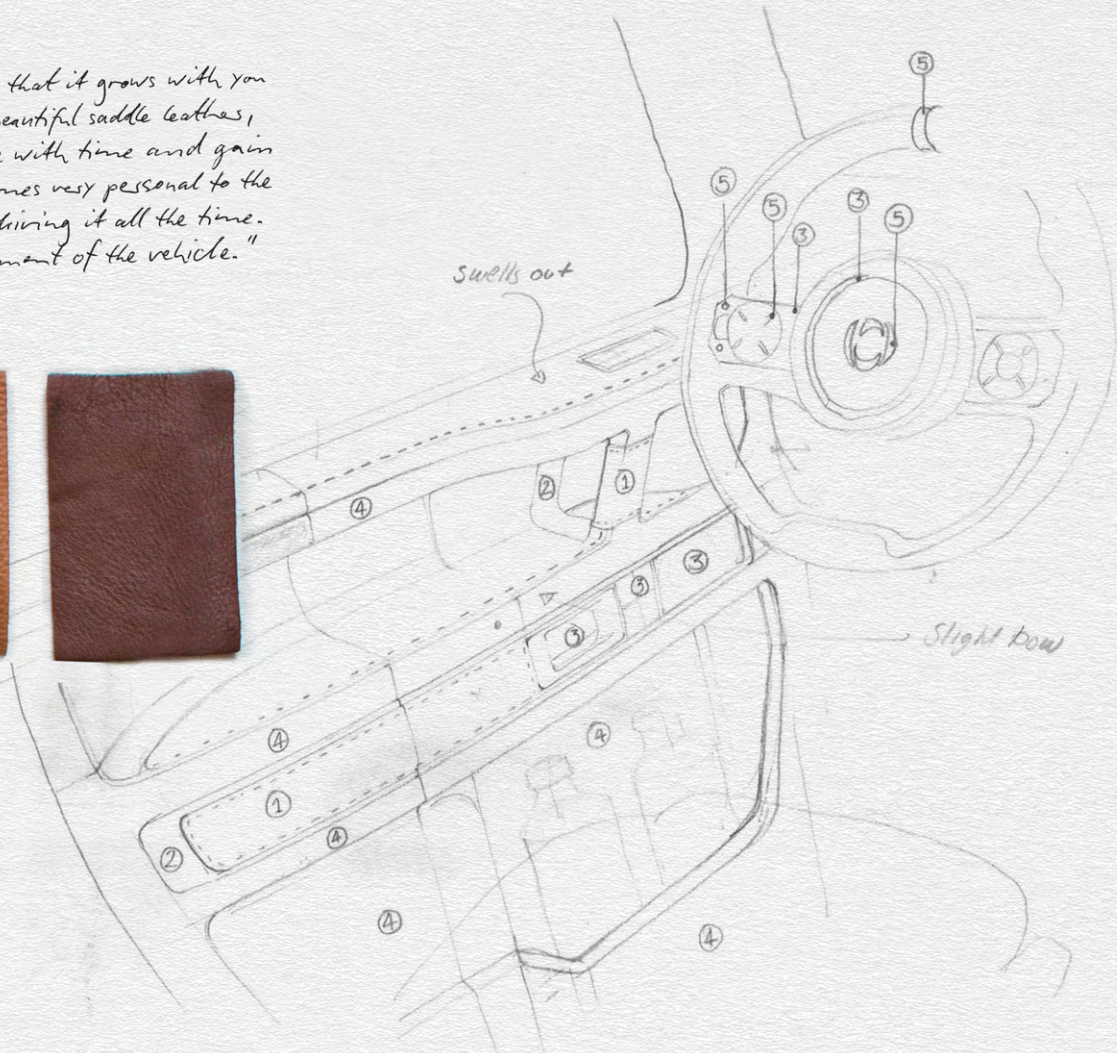

"A round headlight at the front  
and a round rear light is this  
nice idea of something that just  
continues through the vehicle."

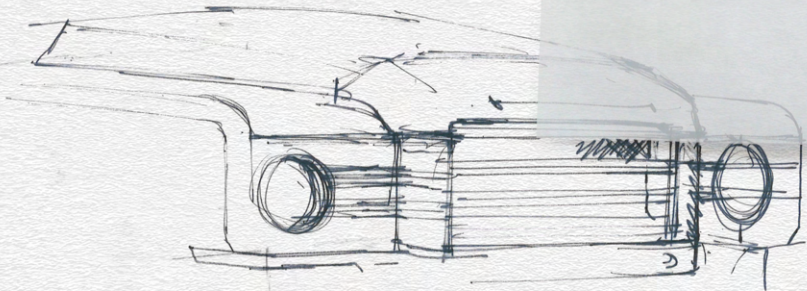
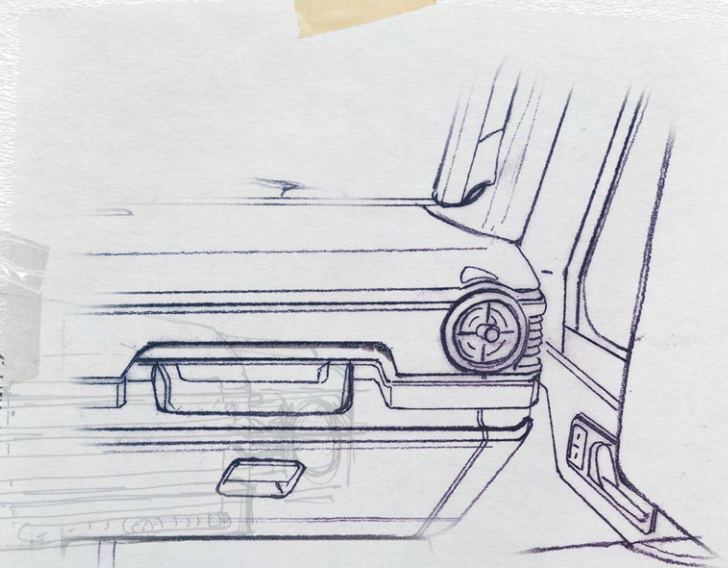
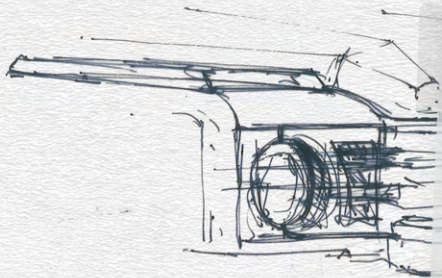



"Having the central stack means that everyone can be engaged in the whole process of driving and on the journey."

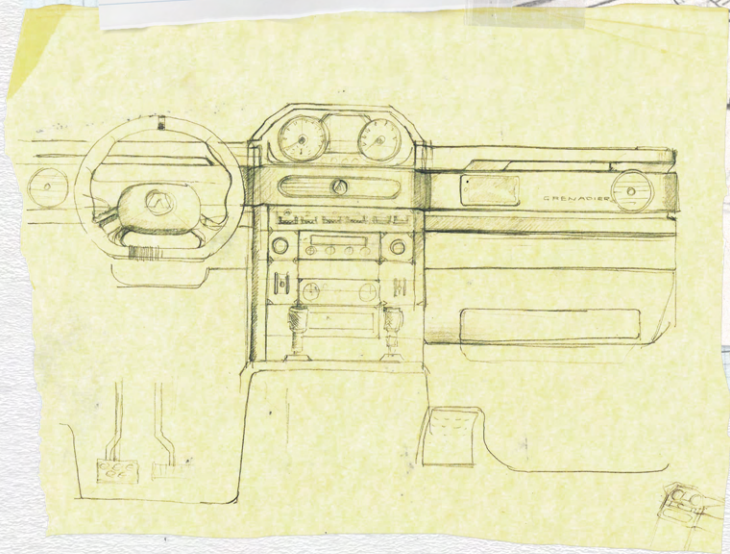
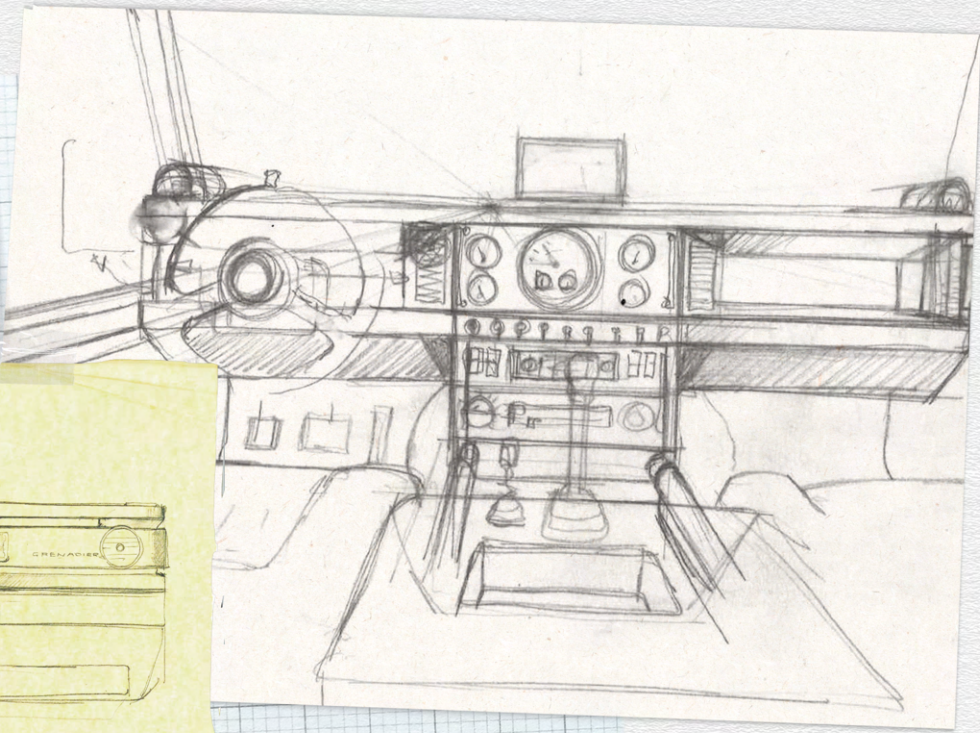

"We didn't set out to make it look like anything else - it was always engineering-led. Function always wins."

## **Copyright**

This publication was correct at the time of going to print. However, we reserve the right to develop, improve and change any equipment, specifications, design and/or information provided without notice or obligation. The manufacturer and agent/dealer will not be held responsible for any inaccuracy or the consequences thereof.

For the latest information, please refer to the online Owner's Manual.

Any software instructions printed inside the book were correct and up to date at the time of printing. However, software can be updated over time with continued improvements over the lifetime of the vehicle. Contact your INEOS representative for further information.

© Copyright INEOS Automotive Limited, 2024. All Rights Reserved. This publication is provided with your vehicle for your personal, private, and non-commercial use. Under no circumstances should the content in this Owner's Manual be reproduced, stored in a retrieval system, or transmitted, in any form, electronic, mechanical, photocopying, recording or other means without prior written permission from INEOS Automotive Limited.



**INEOS**  

---

**GRE<sup>A</sup>DIER**

# TABLE OF CONTENTS

---

INTRODUCTION .....	14
QUICK START .....	19
BEFORE DRIVING .....	29
VEHICLE OPERATION .....	55
DRIVER SUPPORT AND FEATURES .....	93
ADVANCED DRIVER ASSISTANCE SYSTEMS (ADAS) .....	121
MEDIA AND INFOTAINMENT .....	137
CLIMATE CONTROL .....	170
MAINTENANCE AND TECHNICAL INFORMATION .....	174
WARRANTY INFORMATION .....	232

# INTRODUCTION

---

ABOUT THIS MANUAL .....	15
VEHICLE IDENTIFICATION AND ENGINE NUMBER .....	15
DATA RECORDING .....	17
DRIVING SAFETY .....	18

# INTRODUCTION

## ABOUT THIS MANUAL

Thank you for selecting your INEOS Grenadier.

This Owner's Manual is your guide to understanding and operating your vehicle's systems effectively, both on and off the road. We strongly recommend reading it thoroughly before driving to ensure you have full control of your vehicle.

The manual contains crucial information for maintaining the vehicle's reliability, safety, and value. Please note that while the manual covers all variants of the vehicle, some information may not apply to your specific model.

Always adhere to the laws and regulations of your country, as they may differ from the information provided in this manual. It is essential to keep this Owner's Manual with your vehicle at all times for homologation purposes.

The advice provided in this manual serves as a general guide and may not cover every situation. If you have any doubts, consult an INEOS approved Partner for assistance.

## Warnings, Cautions and Notes

The following symbols are used within this Owner's Manual to call your attention to specific types of information. The safety warnings are to ensure care is taken to follow instructions to avoid injury, or serious damage to the vehicle.



**WARNING: Warnings provide awareness of procedures that need to be followed precisely. Failure to follow**

**“WARNING” instructions may result in equipment damage, property damage, and/or personal injury.**



**CAUTION: Cautions provide awareness of possible damage to the equipment and/or vehicle. Failure to follow “CAUTION” instructions may result in equipment damage and/or property damage.**



*NOTE: Notes are provided to show procedures which will help avoid difficulties in the operation of your equipment and/or vehicle.*

## Component Location

Component location and positioning will be described as viewed from the centre of the vehicle looking forward.

## VEHICLE IDENTIFICATION AND ENGINE NUMBER

The Vehicle Identification Number (VIN) consists of seventeen characters.

The VIN can be found in the following locations:

- > Windscreen - Bottom of the windscreen, in the corner.
- > Door Shut - Driver side door shut panel on the manufacturer's label.
- > Chassis Rail - Right side chassis rail (front section of the wheel house).

# INTRODUCTION

Chassis Rail VIN location:

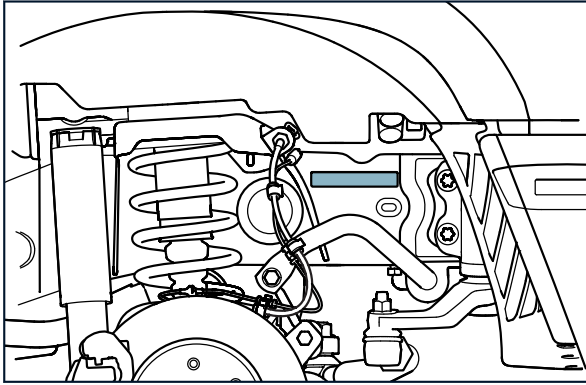

The engine number consists of two separate codes. The first code is the engine number and the second code is the engine identification number or the designation number.

The B57 Diesel engine number, can be found on the engine casing as seen in the following example image:

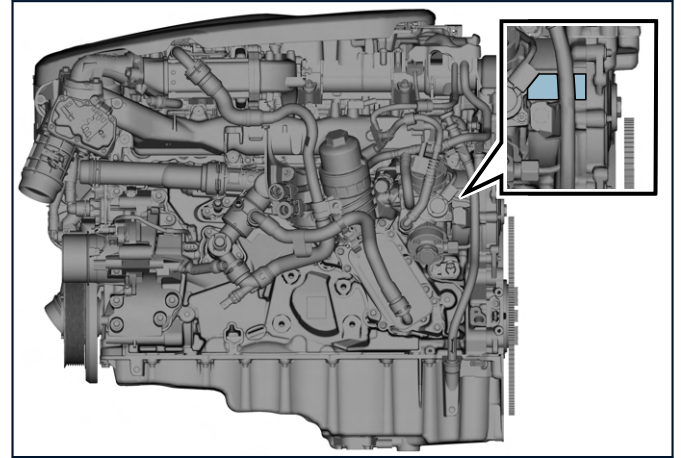



# INTRODUCTION

The B58 Petrol engine number, can be found on the engine casing as seen in the following example image:

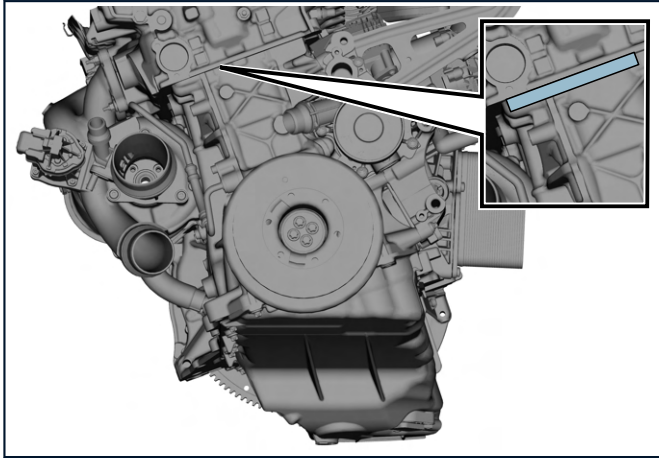

## DATA RECORDING

In this vehicle, electronic modules and components can record detailed data, including various vehicle conditions like faults,

mechanical part status, and safety systems. Recorded data may include, but isn't limited to:

- > Operating conditions of the system.
- > Components such as fill levels for fluids.
- > The use of restraint systems or the conditions of the airbag system.
- > Information about the performance of various systems and modules.
- > Environmental conditions such as carbon emissions and temperature.
- > Information relating to the operation of the vehicle at the time of a near collision, or in the event of a crash, such as, the vehicle speed or brake application.



*NOTE: This vehicle is equipped with an Event Data Recorder (EDR). EDR refers to a device that stores vehicle operation information (whether driving speed, brake pedal, accelerator pedal, etc. operating or not) for a certain period of time before and after an accident, such as a car crash, and has a function to check the stored information. EDR information can help you better understand the accident situation.*

The vehicle's stored data, whether temporary or permanent, can be accessed by authorities like law enforcement or government agencies if needed, using specialised equipment and vehicle access. This access may occur following events such as near-miss collisions

# INTRODUCTION

---

or crashes. Service and repair facilities may also use this data to diagnose malfunctions or errors accurately, ensuring vehicle safety for occupants both on and off-road.



*NOTE: The data and information stored in the vehicle, might also be required by others who may assert a right or obtain your consent to know such information.*

## DRIVING SAFETY



*NOTE: It is important to wear suitable footwear when operating the vehicle to efficiently operate the control pedals. Make sure the area around the pedals is clear and that there will be no obstructions when operating the pedals. This includes checking the floor mats (if applicable) are situated in the correct position.*

- > All occupants should wear the fitted seat belts, when the vehicle is being driven.
- > Never drive under the influence of alcohol or drugs.
- > When driving for long periods of time, take regular breaks.
- > Do not drive when you are tired.
- > Do not use any handheld devices when driving the vehicle.
- > Before driving, be sure to have a clear view through the windscreen and all mirrors including the rear view mirror.

- > All regulations and traffic laws must be obeyed for the safety of all occupants and others around you.
- > Never exceed the legal speed limit in your country.
- > Familiarise yourself with the vehicle and always drive aware of both your own and the vehicles limitations. Failure to operate the vehicle correctly can result in accident and injury.
- > When driving off-road or in extreme conditions, be sure to have suitable supplies and safety equipment in the vehicle with you.
- > Follow the maintenance schedule approved in this guide.
- > Never allow the vehicle to be driven by unqualified drivers.
- > The usage of seat belt dummies is forbidden.
- > As the driver, you are responsible for the occupants in your vehicle. Be sure the occupants also follow applicable safety advice, regulations and traffic laws.

# QUICK START

---

CHECKS BEFORE DRIVING .....	20
CENTRE CONSOLE .....	20
OVERHEAD CONTROL PANEL .....	22
STEERING WHEEL CONTROLS .....	23
ADJUSTING THE STEERING WHEEL .....	24
TELL-TALE LAMPS .....	25
VEHICLE KEY AND IMMOBILISER .....	27

# QUICK START

## CHECKS BEFORE DRIVING

Inspect your vehicle before driving it. This may include, but is not limited to the following:

- > Visually check the road wheels, wheel nuts and tyres.
- > Check that all the windows, mirrors, and lamps are clear and unobstructed.
- > Check the operation of all lamps.
- > Check that the doors are securely closed.
- > Check that the seat, mirrors, and steering wheel adjustments are correct.
- > Check that all gauges and symbols are reading correctly.
- > Check that all passengers have fastened their seat belts.

## CENTRE CONSOLE

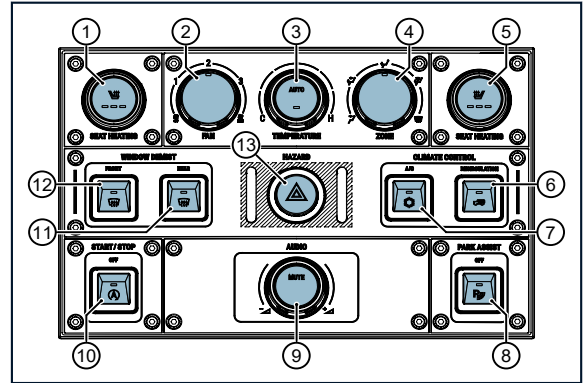

No.	BUTTON	DEFINITION
1	Heated Front Seat (OPTIONAL)	Temperature settings for the driver and passenger seats.
2	Fan Speed Setting	Adjust fan speed in the vehicle cab.
3	Temperature and Auto Setting	Manually adjust cab temperature or set to auto for consistency.
4	Air Flow Zones	Direct air to chosen vents in the vehicle.
5	Heated Front Seat (OPTIONAL)	Heated Front Seats, each with three temperature settings.

## QUICK START

---

No.	BUTTON	DEFINITION
6	Recirculation	Press to recirculate the air inside the vehicle.
7	Air Conditioning	Switch on the Air Conditioning System.
8	Park Assist	Switch Park Assist to passive or disabled.
9	Audio Volume and Mute	Rotate to adjust volume, press mute button to silence audio.
10	ECO Start / Stop	Switch the ECO Start / Stop on or off.
11	Window Demist Rear	Demist Rear Window, optional Heated Mirrors and Washer Jets on.
12	Window Demist Front	Switch the Window Demist Front to on or off.
13	Hazard Warning Lamps	Switch on or off the Hazard Warning Lamps.

# QUICK START

## OVERHEAD CONTROL PANEL

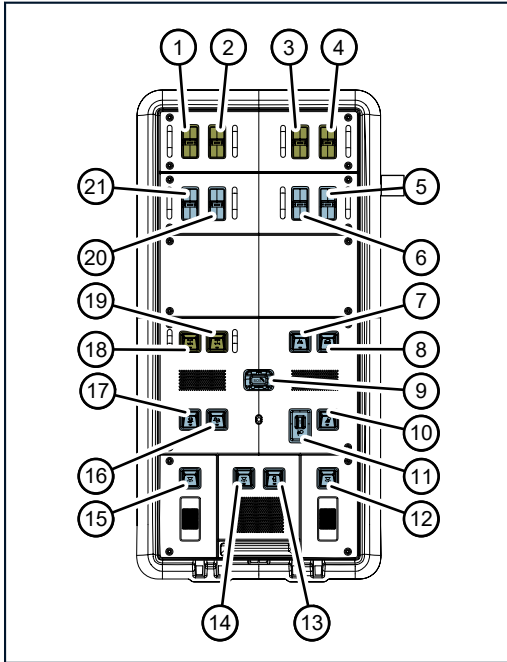

No.	BUTTON	DEFINITION
1	EXT 2	Optional – Toggle 25A Circuit A for front right roof outlet in optional exterior roof power outlets.
2	EXT 3	Optional - Toggle 25A Circuit B for remaining roof outlets in optional exterior roof power outlets.
3	EXT 4	Optional – Toggle front winch (optional) and rear high amp outlet (NATO outlet)
4	EXT 5	Optional - Switch on or off the 25A under bonnet power preparation.
5	INT 2	Switch on or off the 10A right foot-well power preparation.
6	INT 1	Switch on or off the 10A left foot-well power preparation.
7	Off-Road Mode	Activate or Deactivate Off-Road Mode.
8	Wading Mode	Activate or Deactivate Wading Mode.
9	SOS Emergency Call (If applicable)	Open the cover and press the button, to call the emergency services. (If applicable)

## QUICK START

No.	BUTTON	DEFINITION
10	LED Auxiliary High Beam Lights	Toggle to prime the LED Auxiliary High Beam Lights; they activate when the main beam is switched on.
11	Exterior Head Lights - Level	Adjust the level of the Exterior Head Lights.
12	Reading Lamp	Switch on or off, the Reading lamp.
13	Automatic Interior Lamps	Interior lamps illuminate upon door opening.
14	Interior Lamps	Switch on or off the Interior Lamps.
15	Reading Lamp	Switch on or off the Reading Lamp.
16	Downhill Assist	Activate or deactivate the Downhill Assist function.
17	ESC OFF	Toggle Electronic Stability Control function.
18	Differential Lock Front	Optional - Engage or disengage Front Differential Lock.
19	Differential Lock Rear	Optional - Engage or disengage the Rear Differential Lock.
20	EXT 1	Switch on or off the 10A under bonnet power preparation.

No.	BUTTON	DEFINITION
21	PWR	Power vehicle electrical outputs with ignition off.

## STEERING WHEEL CONTROLS

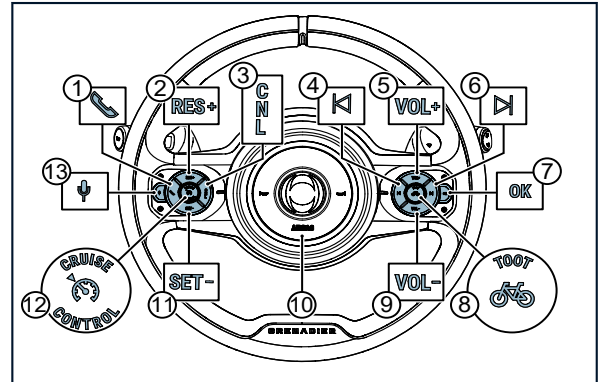

BUTTON	DEFINITION
1	Press to answer a phone call.

# QUICK START

BUTTON	DEFINITION
2	Resume speed or increase speed when using Cruise Control or Downhill Assist.
3	Cancel selection.
4	Skip to previous track or radio station. A long press will perform a track rewind or radio frequency change.
5	Volume increase.
6	Skip to next track or radio station. A long press will perform a track fast forward or radio frequency change.
7	OK to select or confirm selection.
8	Toot tone to alert cyclists or pedestrians.
9	Volume decrease.
10	Main horn to warn others of the vehicle's approach or presence, or to call attention to a hazard.
11	Set speed or decrease speed when using Cruise Control or Downhill Assist.
12	Activates the Cruise Control into standby, ready to be set. Deactivates the Cruise Control.

BUTTON	DEFINITION
13	Voice Recognition ( Apple CarPlay® and Android Auto ).

## Horn and Toot Functions



**WARNING:** Do not use the toot function to alert other vehicles to your presence.

The horn , button (10) in the steering wheel controls above, is used to warn others of the vehicle's presence, or to call attention to a hazard.

007

The toot button , button (8) in the steering wheel controls above, activates a warning tone that is quieter than the standard horn feature. The purpose of the toot, is to politely alert cyclists and/or pedestrians of your presence.

## ADJUSTING THE STEERING WHEEL



**WARNING:** Do not adjust the steering wheel, when the vehicle is in motion. Only adjust the steering wheel position when the vehicle is parked. Adjusting the steering wheel when the vehicle is moving may result in a crash.



## QUICK START

Adjust the steering wheel height for a comfortable driving position by pulling down the lever beside the steering wheel. Then, move the steering wheel up, down, forwards, or backwards until it's comfortable. Once positioned, pull the lever upward to lock it into place.

### TELL-TALE LAMPS

The Tell-tale Cluster, located on a screen behind the steering wheel, lights up to indicate activated features or functions. Upon ignition, it displays various signals with unique meanings. Familiarising yourself with these indicators and their interpretations, as detailed in the table below, is crucial for your awareness and safety.

COLOUR	MEANING
Green or Blue	The function is activated.
Yellow	There is a condition of which you should be aware.
Red	There is a condition that requires your immediate attention.

The following gives more specific information. You should consult the relevant sections and subsections of this manual for more information.



*NOTE: ADAS may not be equipped in your region.*

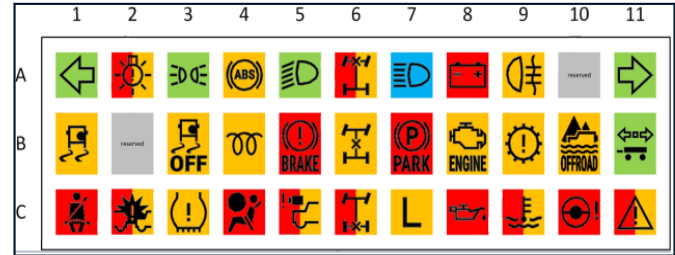

LAMP	MEANING
A1	Left turn signal on
A2	Exterior bulb failure. If you must drive, be aware of this and drive sparingly and accordingly. Consult an INEOS Approved Partner as soon as you can.
A3	Side lamps on
A4	Anti-locking brake fault. If you must drive, be aware that this feature is lacking and drive sparingly and accordingly. Consult an INEOS Approved Partner as soon as you can. Will also illuminate if the rear and/or front differentials are locked.
A5	Low beams on
A6	Front differential lock engaged

## QUICK START

LAMP	MEANING
A7	High beams on
A8	Electrical charge
A9	Rear fog lamps
A11	Right turn signal on
B1	ESC fault. If you must drive, be aware that this feature is lacking and drive sparingly and accordingly, particularly on slick roads. Consult an INEOS Approved Partner as soon as you can. Will also blink when actively supporting driver.
B3	Electronic Stability Control (ESC) off
B4	Diesel Preheat
B5	Brake system fault. If this is illuminated, do not drive your Grenadier. Have it towed to an INEOS Approved Partner.
B6	Centre differential engaged
B7	Parking brake on. Note that this means only that the brake is on enough to trigger the switch. The parking brake lever may not be pulled enough to keep your Grenadier stationary, particularly on slopes and under heavy loads.

LAMP	MEANING
B8	Check the engine. If this is illuminated, limit your driving and consult an INEOS dealer as soon as you can. If the lamp is red, stop driving immediately. Park your Grenadier in a safe place and contact an INEOS Approved Partner to have your Grenadier towed there.
B9	Transmission failure - If there is a fault, do not drive your Grenadier and consult with an INEOS Approved Partner.
B10	Off-road Mode/Wading Mode engaged
B11	Trailer turn signal
C1	Seat Belt Warning. Seated front seat passenger and/or driver is unbuckled or rear seat passenger/passengers unbuckled during driving. Please make sure that all passengers are buckled.
C2	Forward Collision Warning. If this is illuminated, there is an error in the system or AEB (Automatic Emergency Braking) has been deactivated by the driver. If the lamp is red, the AEB (Automatic Emergency Braking) system detects possible danger.

# QUICK START

LAMP	MEANING
C3	Low tyre pressure warning. Pull over. Inspect your tyres for damage. Adjust your tyre pressure to the recommended level.
C4	Airbag fault. If you must drive, be aware that this feature is lacking and drive sparingly and accordingly. Consult an INEOS Approved Partner as soon as you can.
C5	Front Camera View warning. If this is illuminated, the camera is obstructed and ADAS systems will not be available.
C6	Rear differential lock engaged
C7	Low gear indication
C8	Engine oil low
C9	Coolant temperature
C10	Steering system failure. If the lamp is illuminated, stop driving immediately. Park your Grenadier in a safe place and contact an INEOS Approved Partner to have your Grenadier towed there.
C11	Overall warning. If the lamp is red, stop driving immediately. Park your Grenadier in a safe place and contact an INEOS Approved Partner to have your Grenadier towed there.

## VEHICLE KEY AND IMMOBILISER



**WARNING:** Ensure the vehicle key is not left inside with occupants, like young children or pets.



**WARNING:** Keep batteries out of reach of children. If swallowed or inserted into the body, seek medical attention immediately.



**WARNING:** If the battery compartment won't close securely, stop using the product and keep it away from children.

The Grenadier's passive anti-theft system enhances vehicle security, relying on electronic immobilisation to prevent engine start-up without designated keys. An electronic chip within the key communicates with the vehicle's security system, ensuring only recognised keys enable ignition, fuel injection, and starter

# QUICK START

engagement. When locking the vehicle, the headlights briefly illuminate for added visibility.

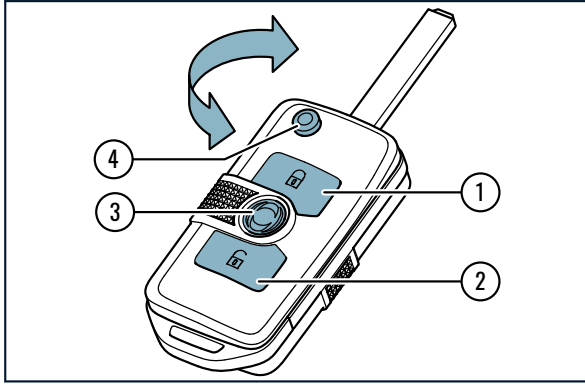

No.	BUTTON	FUNCTION
1	Lock	Press to lock and arm the security system.
2	Unlock	Unlock the drivers door. Double press for all doors.
3	Panic	The panic button will set off the alarm.
4	Key Blade	Press to release the key blade for manual locking and unlocking.

## Key Fob Battery Replacement



**WARNING:** Keep batteries out of reach of children. If you think batteries may have been swallowed or placed inside any part of the body, seek immediate medical attention.



**WARNING:** If swallowed, a lithium button battery can cause severe or fatal injuries within 2 hours. Seek immediate medical attention.

The vehicle key operates on battery power, and the battery may need replacing to ensure the remote fob functions properly. Simply remove the back cover of the key fob to access the battery, replace it, and reattach the cover.



**NOTE:** Dispose of old batteries at designated recycling points, adhering to environmental regulations. Do not discarding them in household waste.



## BEFORE DRIVING

---

SEATING .....	30
OCCUPANT RESTRAINT SYSTEM .....	35
SEAT BELTS .....	36
AIRBAGS .....	40
CHILD SAFETY .....	45
ISOFIX (LOWER UNIVERSAL ANCHORAGE SYSTEM) AND I-SIZE ANCHORS .....	49
CHILD SEAT WITH SEAT BELT INSTALLATION .....	52
CHILD DOOR LOCKS .....	53
ALCOHOL INTERLOCK (OPTIONAL) .....	53

# BEFORE DRIVING

## SEATING

### Correct Driving Position

 **WARNING: Make sure the seat is correctly adjusted before you drive the vehicle.**

Before driving, review the following list of suggestions on how to position the drivers seat correctly:

- > Make sure your seat is high enough to give you a good view of the road, while still allowing clearance above your head. Your hips should be at least as high as your knees.
- > Move the seat until you can easily push down the pedals fully.
- > Make sure your thighs are supported without pressure around your knees.
- > Check the angle of the seat back rest and adjust to a comfortable driving position.
- > The steering wheel is adjustable, make sure you can reach it easily and that it does not obstruct your view of anything vital on the dashboard.
- > Adjust the head restraint, so that it is as high as the top of your head and as close to the rear of your head as possible to avoid whiplash injuries.
- > Buckle your seat belt and make sure it is adjusted correctly so it is tight, with the lap belt over the pelvic region and the

diagonal strap over the shoulder, not the neck. Pregnant women should put the lap belt flat on their thighs beneath their abdomen.

### Front Seat Adjustment

 **WARNING: Do not adjust the driver's seat while driving to prevent unexpected movements that may lead to loss of control, accidents, injuries or death.**

 **WARNING: Do not store objects under or around the seats, as they may interfere with pedal controls and cause accidents. Excluding the INEOS supplied tool-kit, which is designed to be safely secured under the seat.**

 **WARNING: Ensure seats are firmly adjusted and locked into place once a comfortable driving position is achieved. Verify correct seat positioning before driving to prevent unexpected movement while in motion.**

Both driver and front passenger seats are fully adjustable, allowing occupants to adjust seating height, fore and aft position, and backrest angle for safety and comfort.

 **CAUTION: Immediately dry seats and front seat mechanisms, including sliding rails, if exposed to water.**

# BEFORE DRIVING

## Seat Height

To adjust the seating height, pull the height adjustment lever upwards to raise the seat position. Using the same lever, push downwards to lower the seating position. The lever will need to be pulled or pushed several times, until the desired position is achieved.

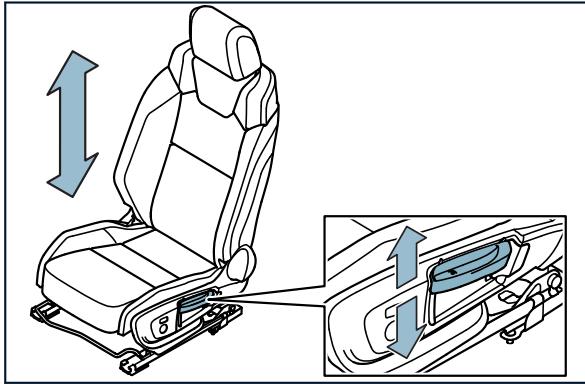

## Longitudinal adjustment



**WARNING:** Do not sit nearer than 25 cm to the steering wheel. This will allow safe operation of the steering wheel airbag.

Lift the bar upwards, to slide the seat forward or backwards.



*NOTE:* Be sure the seat is secured into position before driving.

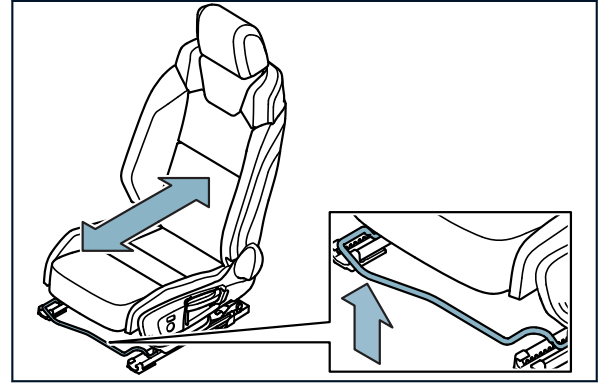

## Backrest Angle Adjustment



**WARNING:** Do not adjust the seat backrest too far back. This can cause the seat occupant to slide under the seat belt, resulting in injury or death in the event of a crash.

## BEFORE DRIVING

Use the control lever to adjust the angle of the backrest. To adjust the backrest backwards or forwards, turn the lever towards the back of the vehicle and lean against the backrest until correctly positioned.

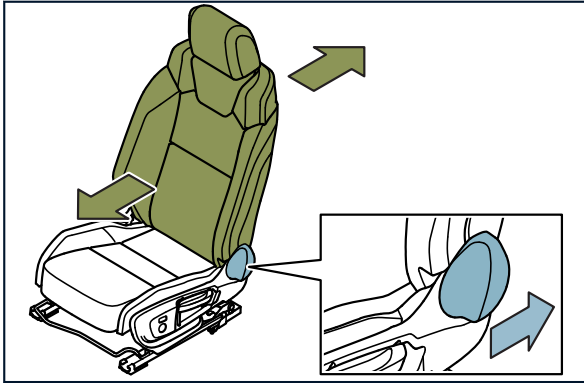

### Front Head Restraints

The front head restraints are removable. To remove the head restraint, push the control button inwards at the base and pull the head restraint until fully detached.

To install the head restraint, push the control button inwards and push the head restraint into the location holes in the top of the seat.

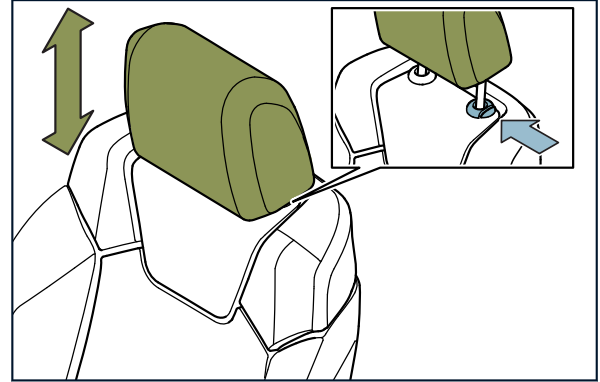

### Rear Head Restraints



**WARNING:** Children should not adjust or remove the headrest unless specifically instructed to.



## BEFORE DRIVING

All head restraints are removable. To remove the head restraint, push the control button inwards at the base and pull the head restraint until detached.

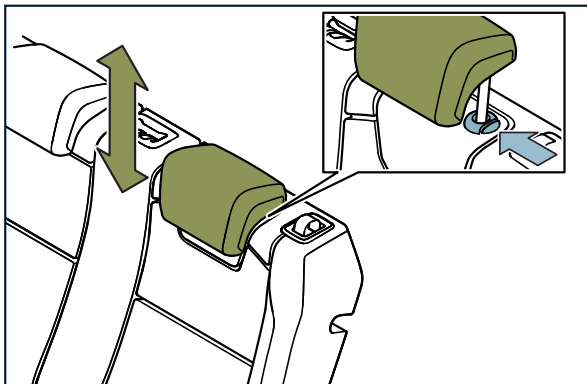

To install the head restraint, push the control button inwards and push the head restraint into the location holes on the top of the seat.

### Head Restraint Adjustment

 **WARNING:** The adjustable head restraint is a safety device. Whenever possible it should be installed and properly adjusted when the seat is occupied. Failure to adjust the head restraint properly could reduce its effectiveness during certain impacts.

To adjust the head restraint, pull the head restraint upwards until the head restraint is in a comfortable position. To lower the headrest back down, push the control button at the base of the headrest. Make sure the head restraint is locked into position before driving the vehicle.

### Folding Rear Seats

 **NOTE:** INEOS recommends lifting and tilting the lower cushion forward and removing the headrest to lie the back support section down flat. This protects the headrest once stored away and the lower cushion provides protection to the front seats.

 **WARNING:** Always check the seat belt buckle is not trapped when lifting and tilting the lower cushion. If the seat belt is trapped when lifting this can cause injury to occupants or damage to the seating.

 **CAUTION:** Before folding the back support section of the seats make sure the seat belt buckle is situated inside the storage slot. Failure to do so can cause damage to the seats and the seat belt buckle.

 **CAUTION:** Do not fold the rear seats when hosing down the Loadspace. The rear seats must be upright when hosing.

The rear seats are split into a 60:40 divide and can be folded down.

## BEFORE DRIVING

There are two options when folding the rear seat, the first option is to fold the rear back support section forwards to lie flat on top of the lower cushion. The second method is to remove the headrest, followed by folding the bottom cushion of the seat towards the front of the vehicle (1) and pull the loop located above the single outer seat (2).

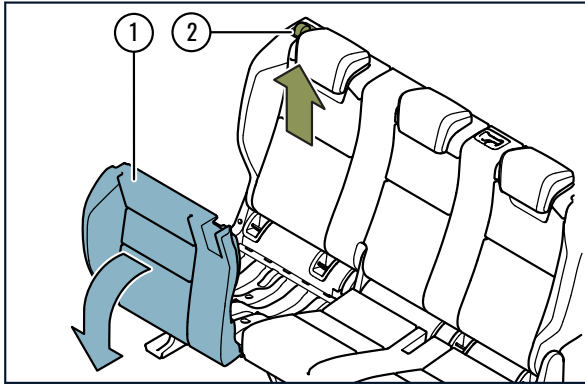

Fold the backrest forward to collapse the seat (3).

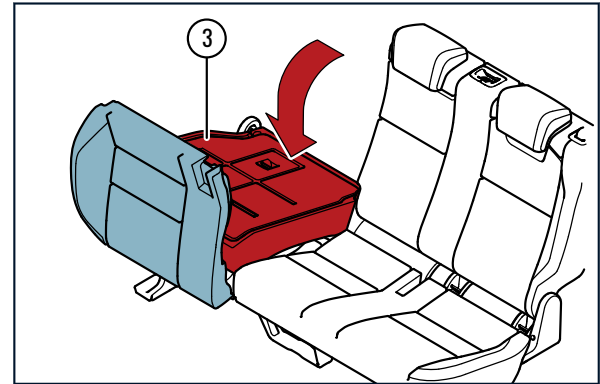

**WARNING:** When unfolding the seats back into position for use as a seat, you must make sure the seat is locked into position. There will be a red indicator near the loop strap when the seats are not locked into place. When the red indicator is not visible the seat is in the locked position. Always try to move the seats, even when there is no red indicator.



**WARNING:** Move the seat belt away from the seat when folding the back support section back into an upright position. This stops the seat belt being caught on the back support section.

## BEFORE DRIVING



**WARNING:** Be careful to not trap your hands or arms between the seat, interior and the catch when you lock it into position.

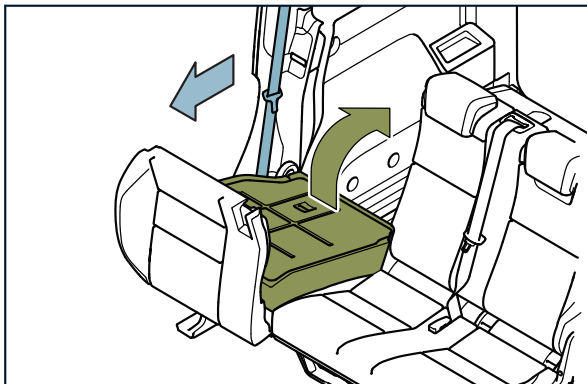

**NOTE:** The seats should always be upright for the interior cleaning process.

### OCCUPANT RESTRAINT SYSTEM

The Occupant Restraint System is designed to protect the occupants of the vehicle in a variety of impact conditions.

The system consists of:

- > Driver and front passenger seat belts with pre-tensioner(s) and load limiting systems.
- > Rear seat belts.
- > Dual stage driver and passenger airbags.
- > Curtain airbags on both sides of the vehicle.
- > Thorax airbags both sides of the vehicle. (Driver and front passenger only)

The vehicle is fitted with an Airbag Control Module (ACM) to measure the seat occupancy conditions. Using a deployment matrix, the ACM calculates if and where the airbags need to be deployed.

In the case of a crash, the ACM will determine the necessary restraint system to be activated. If the Airbags or pre-tensioner(s) do not operate in a collision it does not mean there is something wrong with the system. The ACM will take all readings and information into consideration, along with the vehicle conditions at the time of the accident. This may result in the conditions not being appropriate to trigger the operation of any stages of airbag deployment, seat belt pre-tensioner(s) and other safety devices.

## BEFORE DRIVING

The airbags locations in the vehicle are highlighted by an 'AIRBAG' imprint or marker around the interior. For example, the steering wheel has 'AIRBAG' imprinted into the centre section.

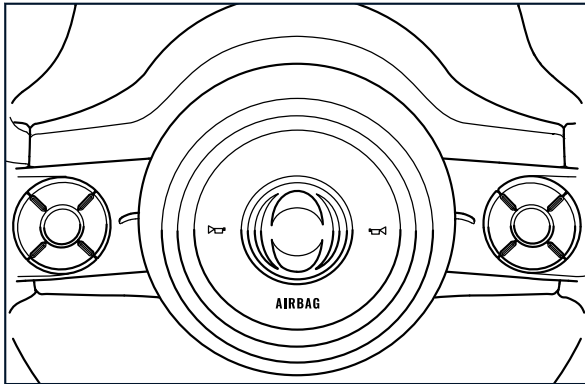





### Determining if the System is Operational

The airbag system warning symbol  is shown in the tell-tale instrument cluster to provide the condition of the system, once the ignition is set to ON. If the airbag system warning symbol illuminates while driving, then this is signaling a fault with the airbag system. A warning message will be displayed on the infotainment screen with a description of the fault.













If either of these conditions occur, even intermittently, have the restraint system inspected by your INEOS approved partner immediately. Unless investigated and repaired, the system may not operate correctly in the event of an incident such as a crash.

### SEAT BELTS

-  **WARNING:** It is essential to wear your seat belt. Not wearing a seat belt increases the chance of serious injury or death in the event of an accident.
-  **WARNING:** Seat belts should not be twisted. This may result in injury when heavy braking.
-  **WARNING:** Never place the shoulder section of the seat belt behind your back or under your arm. In the event of an accident or sudden braking, this may lead to injury.
-  **WARNING:** Belts are designed for adults. Therefore infants and small children must be restrained in approved child safety seat restraints.
-  **WARNING:** Keep the seat belts well maintained and where possible, avoid contact with sharp objects and edgings. Failure to do this, will result in the webbing of the seat belt cutting or abrading, weakening the seat belt. This may lead to seat belt failure, during heavy braking or during an accident, causing serious injury or even death.

## BEFORE DRIVING

---

-  **WARNING:** Each seat belt assembly must only be used by one occupant. It is dangerous to put a seat belt around a child being carried on the passengers lap. Do not put an adult seat belt around two children.
-  **WARNING:** It is essential that all the passengers are correctly seated with the required restraints in place, for their own safety and the safety of others in the vehicle. Even with airbags, injuries and possible death can occur if seat belts are not worn correctly.
-  **WARNING:** Reclining the seat back can significantly decrease the protection provided by the seat belt in the event of an accident. Adjust the seat back to an upright position. Make sure that the seat back is locked in place, otherwise it could move forward in the event of a sudden stop or crash and cause injury.
-  **WARNING:** Seat belts are designed to bear upon the bony structure of the body, and should be worn low across the front of the pelvis, chest and shoulders. Wearing the lap section of the seat belt across the abdominal area must be avoided.
-  **WARNING:** Always remove rigid or breakable objects such as spectacles or a mobile phone, from your pockets. These items could be trapped under seat belts, possibly causing injury in the event of an accident.
-  **WARNING:** Expectant mothers should seek medical advice on the most appropriate way to wear the seat belt.
-  **WARNING:** No modifications or additions should be made by the user which will either prevent seat belt adjusting devices from operating, or prevent seat belt assembly from being adjusted to remove slack. Never install accessories on your seat belts.
-  **WARNING:** Once the seat belt is engaged, make sure the seat belt is as tight as possible without causing discomfort, eliminating any unnecessary slack to provide the protection for which they have been designed.
-  **WARNING:** The use of seat belt dummies is forbidden. Do not use seat belt dummies.
-  **WARNING:** The entire seat belt assembly should be replaced if subject to an accident or crash, even if there are no clear signs of wear or impact damage.
-  **WARNING:** If it is necessary to replace a seat belt on this vehicle, then it **MUST** be replaced with an approved seat belt. The approved seat belts for the front seats must also include a load limiting system.
-  **CAUTION:** Seat belts must be kept clean, to ensure the retraction device works correctly. Make sure that belt webbing is not twisted, looped, frayed or obstructed in

# BEFORE DRIVING

any way. If in doubt about condition or operation of seat belt restraints, seek help and advice from an INEOS approved partner.



**CAUTION:** Seat belt webbing can become contaminated or damaged from exposure to substances such as polishes, oils and chemicals and particularly battery acid. If the seat belts do require cleaning, it is recommended to only use mild soap and water. If the seat belt webbing does become frayed, contaminated or damaged then a replacement should be installed.

## Pre-tensioner and Load Limiting

There are pre-tensioners and load limiting systems installed on the front seat belts for safety purposes.

The pre-tensioners reduce the slack in the seat belts after frontal or near frontal impacts. The pre-tensioners are designed to keep the occupants in position within the seats to avoid forward displacement. The belt force limiter will reduce the pressure on the occupants when the shoulder strap registers a force greater than a certain limit, reducing stress on the occupants, to avoid seat belt related injuries in a sudden stop or collision. Once the belt force limiter has been triggered, a forward displacement of the occupant takes place, so that the frontal airbags take over a larger part of the restraint effect.



*NOTE: In some moderate frontal or rear accidents, only the pre-tensioner system will deploy.*

## Seat Belt Fastening



*NOTE: The seat belt may lock if parked on an incline as the seat belt webbing is withdrawn. If the mechanism does lock gently release the tension on the seat belt and slowly guide the belt webbing until the belt is fully withdrawn into place.*

All seats in the vehicle, are equipped with three point inertia reel seat belts.

1. The front seat belts enter and exit from the interior B-pillar. The rear seat belts enter and exit from the top of the rear seat back rest.
2. Seat belt anchor point.
3. Seat belt buckle latch location.

## BEFORE DRIVING

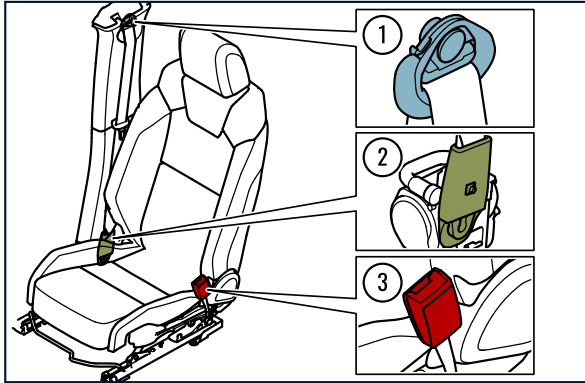

The inertia seat belt reels are designed to automatically apply tension to the seat belt when necessary for safety with comfort, but the reels will lock under severe braking or in the event of a collision.

To test the seat belt and the locking feature of the inertia belt reels, quickly pull the seat belt strap forwards. The seat belt should lock as you are replicating a sudden movement of force, such as, sudden braking. If the locking mechanism does not lock the seat belt in this test you should consult your recommended INEOS approved partner.

To fasten the seat belt, pull the seat belt out over the shoulder ensuring you have grip of the seat belt buckle tongue. Pull across the chest and down towards the seat belt buckle latch.

Push the seat belt buckle tongue into the buckle latch until you hear a click.

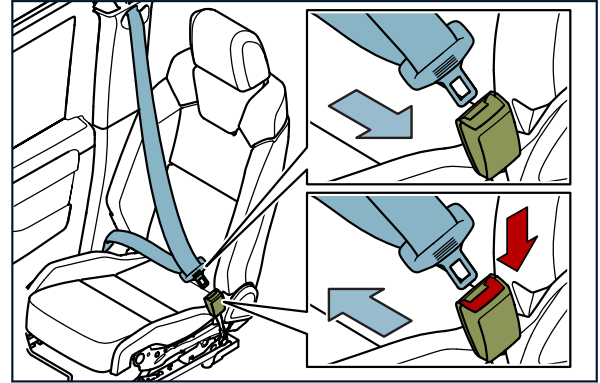

*NOTE: It is advised to pull the seat belt down, across the body, after a positive click is heard, this is to ensure that the seat belt is correctly latched, inside the buckle.*

### Seat Belt Reminder

The seat belt reminder warning symbol  illuminates in the tell-tale cluster, along with an acoustic warning sound, to signal that an occupied front seat has a disengaged seat belt.

# BEFORE DRIVING

The seat belt reminder will be activated, if the vehicle reaches a speed of 15mph (25km/h). The acoustic signal will be heard for 93 seconds.

The back seat warning symbol  will illuminate and an acoustic signal will be heard if any of the rear seat belts are unbuckled whilst the vehicle is motion.

## Seat Belt Unfastening

 **WARNING:** Do not allow the seat belt to twist, when retracting to the stored position. Failure to do so may result in injury or even death in the event of a crash.

 **WARNING:** All passengers, including the driver, should always wear seat belts, whether or not an airbag is provided, to decrease the risk of injury or death in the event of a crash

 **CAUTION:** Always guide the retracting seat belt webbing to the stored position to avoid the seat belt buckle tongue hitting interior surfaces or windows.

Grip the seat belt buckle tongue and push the button on the buckle latch to release. Take care gently guiding the seat belt webbing to slowly retract to the original stored position.

## AIRBAGS

 **WARNING:** Read and understand the airbag safety labels to comply with the instructions before driving.

 **WARNING:** If the airbag warning lamp is illuminated after the engine has started or while driving the vehicle, then have the vehicle immediately inspected by an INEOS approved partner.

 **WARNING:** Do not try to repair or modify the airbags or any safety system. Repairs done by anyone other than an INEOS approved partner may lead to system malfunction or failure. All safety system work should be done exclusively by an INEOS approved partner.

 **WARNING:** Never use a rearward facing child restraint on a seat protected by an active airbag in front of it, death or serious injury to the child can occur.

The Airbag System is designed to safeguard all occupants during sudden braking or severe impacts. Working alongside seat belt pretensioners, the airbags deploy in serious frontal collisions.

Airbag safety labels are located within the vehicle for all occupants' attention. Read and understand these labels to comply with instructions before driving.



## BEFORE DRIVING

**i** *NOTE: Identify airbags in the vehicle by the 'AIRBAG' marking at their location. For example, refer to the image of the steering wheel below.*

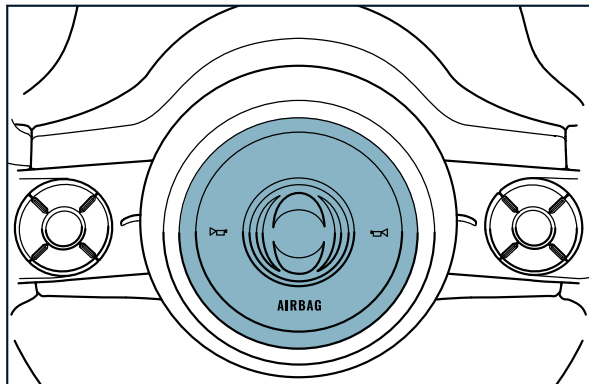

The airbags are located in the following locations within the vehicle:

1. The driver's airbag is located in the steering wheel (1).
2. The passenger airbag (2), is located on the upper glove compartment.
3. The side thorax airbags (3), are located in the front driver and passenger seats.
4. The curtain airbags (4) are located in the roof trim.

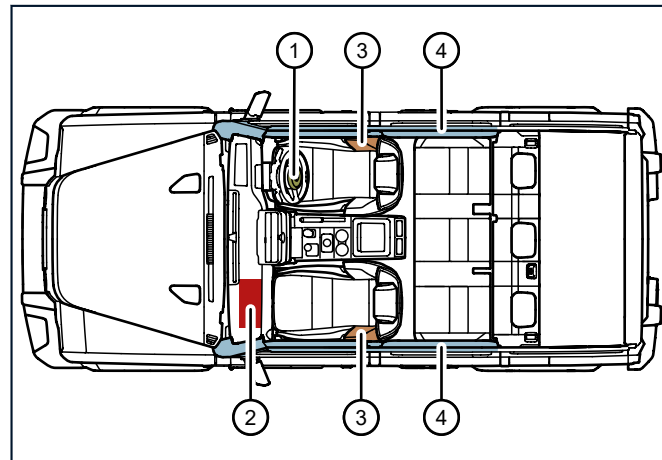

**i** *NOTE: Airbag safety labels are located on the front passenger sun visor. The instructions on these labels must be read and understood before driving the vehicle.*

### Airbag Deployment





**WARNING: Improper handling or tampering could result in accidental deployment of the airbags, resulting in injury or death.**

## BEFORE DRIVING

 **WARNING:** Do not attempt to drive the vehicle when the airbags have deployed. The vehicle must be recovered safely and securely.

 **WARNING:** The use of third party accessory seat covers may prevent the deployment of the seat side airbags and increase the risk of injury in an accident.

 **WARNING:** All passengers, including the driver, should always wear seat belts, whether or not an airbag is provided, to decrease the risk of injury or death in the event of a crash.

 **WARNING:** No objects should be attached to, or placed on, the centre cover of the steering wheel or the front passenger fascia panel. Such objects could cause harm if the vehicle is in a collision severe enough to cause the airbags to deploy.

 **WARNING:** There may be potential for minor friction injury when the airbags deploy. This may be caused by contact from the rapidly deploying airbag with bare skin.

 **WARNING:** If an airbag deploys, there is a chance of temporary hearing loss due to the noise as a result of the airbag deployment.

 **WARNING:** The smoke and dust formed when the airbags are deployed can cause skin and eye irritation in

the event of prolonged exposure. Seek medical help if any irritation occurs.

 **WARNING:** Avoid touching safety restraint components immediately after deployment, as there is a risk of sustaining burns.

 *NOTE: The airbag system is not designed to protect against rear impacts.*

The airbag system is designed to provide additional protection. However, the airbags do inflate within a few thousandths of a second and with considerable force. There is therefore, a risk of death or serious injury. The risk of injury is heightened if the passengers are not seated correctly in the correct position or are not restrained correctly from improper use of the seat belts when the airbags deploy.

The system will not deploy in the event of minor frontal or side impacts, such as minor impacts when parking.

When maintenance is required near to an airbag, seek advice from an INEOS approved partner. Failure to do so, can cause inadvertent airbag deployment.

### Driver and Front Passenger Airbags

 **WARNING:** Seat belts must be worn and the occupants must be sat correctly sitting upright, with their feet on the floor and their backs against the backrest for the

## BEFORE DRIVING

**airbags to work as designed and to avoid further injury or even death.**

The sensors and one or more of the airbags will trigger, if there is a frontal impact of sufficient force. The airbags will help to protect the driver and passenger in the event of a collision, to avoid injury or even death. The airbags inflate and then deflate to cushion the impact of the driver and passenger during a frontal collision. The system is designed to reduce injury to the head, neck, face, chest and legs.

 **NOTE:** There can be a small amount of powder and/or smoke released into the cab around the driver and passengers when the airbags activate.

### Passenger Airbag Deactivation

 **WARNING:** If the passenger airbag is showing as deactivated but the airbag warning lamp is on, then do not allow adults or children to use the passenger seat. Consult immediately with an INEOS approved partner.

The passenger airbag lamps (A) are located on the overhead control panel.

During the start-up of the vehicle all the passenger airbag lamps will be illuminated as the vehicle is self testing.

If the passenger airbag is active after the self-testing has finished, then the 'ON' lamp and the text 'PASSENGER AIRBAG' will be

illuminated for up to 60 seconds. At this point there will be no lamp or text illuminated and the passenger airbag stays active.

If the passenger airbag is deactivated after the self-testing process has finished, then the 'OFF' Lamp and the text 'PASSENGER AIRBAG' will be illuminated continuously to indicate that the passenger airbag is deactivated.

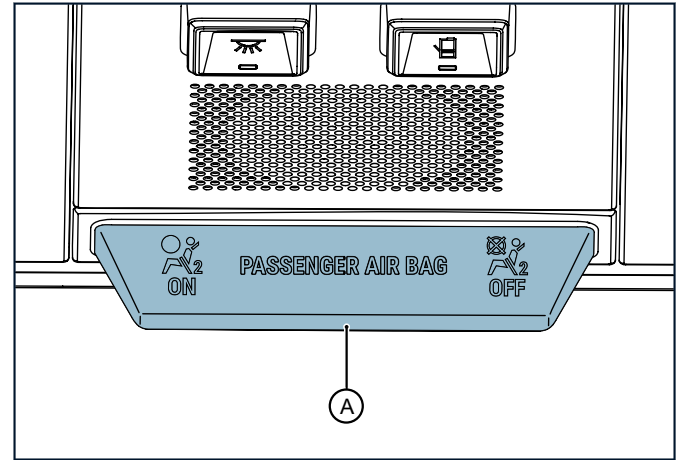

To deactivate the passenger airbag make sure the handbrake has been engaged and the vehicle is in gear park (P). Do not press the brake pedal at this time.

# BEFORE DRIVING

---

Press the 'Passenger Airbag' button using the infotainment system. This will then prompt you to press the brake pedal for three seconds. You will receive a confirmation on the infotainment system that the airbag has been disabled.

If there is no confirmation, do not assume the airbag is deactivated. Try the process again from the beginning. If the confirmation fails to appear again then contact an INEOS approved partner and do not install any child restraint to the front passenger seat.

To reactivate the passenger airbag, engage the handbrake and ensure the vehicle is in gear park (P). Do not press the brake pedal at this time.

Press the 'Passenger Airbag' button using the infotainment system. This will then prompt you to press the brake pedal for three seconds. You will receive a confirmation on the infotainment system that the airbag has been activated.

## Inflatable Curtain



**WARNING: Do not hang anything from the handles in the roof of the vehicle that may cause injury or even death in the event of the Inflatable Curtain activating. This may include anything hard, sharp or heavy. Failure to do so may result in serious injury or even death.**

The Inflatable Curtain, prevents the occupants from striking their heads on the inside of the vehicle in the event of a collision. If the collision is of a sufficient force, then the sensors within the vehicle will trigger and the Inflatable Curtain may deploy.

## Side Airbag (Thorax Airbag)

The Thorax Airbags are located in the front driver and passenger seats, specifically the outer backrest. The airbags will deploy in the event of a collision of sufficient force. The space between the front seats and the doors will be cushioned, to try and help prevent injury and/or death to the occupants, if the impact of the collision forces the body towards the vehicle door.



*NOTE: The Thorax Airbags may only deploy on the side of the vehicle that is impacted by the collision.*

## Airbag Malfunction



**WARNING: In the case of an active airbag warning light, do not install child restraint systems on the front passenger seat.**

The vehicle will self test upon start up. The airbag warning lamp  will be illuminated for up to 10 seconds and switch off to confirm no faults identified. If after six seconds the airbag warning lamp is still illuminated then there is a confirmed fault with the airbag system. Immediately seek professional advice from your nearest INEOS approved service centre.

## BEFORE DRIVING

### CHILD SAFETY

The following points are strongly recommended by INEOS for the safety of children when travelling:

- > Children, should sit in the rear passenger seats.
- > Children should always be restrained using the correct restraint method, regardless of their age when travelling in the vehicle.
- > Always use ISOFIX (Lower Universal Anchorage System) / i-Size anchors where available.

 **WARNING:** Never use a rearward facing child restraint on a seat protected by an active airbag in front of it, death or serious injury to the child can occur.



 **WARNING:** A suitable child restraint, correctly installed and used, provides the highest degree of protection for infants and small children in most accident situations.

 **WARNING:** The passenger airbag must be deactivated when using a child seat restraint on the front passenger seat. If not, the triggering of the airbags poses a risk of fatal injury to the child. This is especially the case if rear facing child restraint systems are used on the front passenger seat.

 **WARNING:** The seat belt reminder function is only designed to recognise an adult sized occupant and will not be activated by a child seat. If a child seat is to be secured to the front passenger seat with a seat belt, make sure it is correctly installed in accordance with the manufacturer's instructions. A child seat that is not correctly restrained can cause an infant or child to be seriously injured or killed in a crash.

 **WARNING:** Do not allow children to travel in a vehicle without being correctly restrained. An appropriate child seat or harness should always be used.









 **WARNING:** Each seat belt assembly must be used by only one passenger. Putting a seat belt around a child being carried on a passengers lap is dangerous.

 **WARNING:** When using child seats, make sure the installed child seat does not rest or lean against the interior door or windows to avoid injuries when travelling.

## BEFORE DRIVING

 **NOTE:** Do not cover the child restraint systems with items or materials and do not affix items to the child restraint systems.

### Child Restraint System Seating

SEAT NUMBER	SEAT POSITION	MARKING	NOTICE
1	Front passenger seat	 	(1), (2), (3)
2	Rear seat, left side	  	(2), (3)
3	Rear seat, centre		(2), (3)
4	Rear seat, right side	  	(2), (3)

 **NOTE:** The table above applies to both left and right hand drive. Seat positions 1, 2, 3 and 4 remain as the same seats, regardless of right hand or left hand drive.

### Definitions of the markings within the 'Child Restraint System Seating' table:

 = It is suitable for ISOFIX (Lower Universal Anchorage System) / i-Size child restraint systems.

 = This seat is equipped with a top tether anchorage point.

 = Never use a rear-facing child restraint system on the front passenger's seat when the front passenger airbag is activated.

 = It is suitable for a universal category child restraint system to be fixed with the vehicle seat belt.

### Descriptions for the 'NOTICE' column inside the table:

(1) = Move the front seat fully rearward.

(2) = When you install a front-facing child restraint, if there is a space between the child restraint and the backrest, adjust the backrest angle in order to install the child restraint system properly.

# BEFORE DRIVING

(3) = If the head restraint interferes with the child restraint system, adjust the height of the head restraint or remove it, as necessary.

## Detailed Information for Child Restraint System

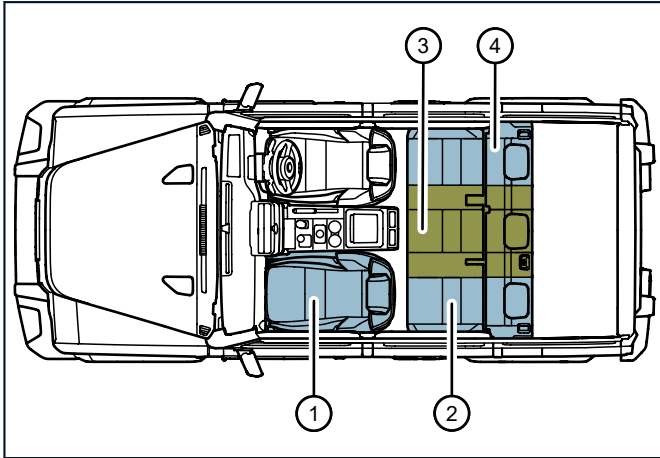

DESCRIPTION	SEAT POSITION NUMBER				
	1 (FPA Activated)	1 (FPA Deactivated)	2	3	4
Seating position suitable for universal belted (YES/NO)	NO	YES	YES	YES	YES
i-Size seating position (YES/NO)	NO	NO	YES	NO	YES

# BEFORE DRIVING

DESCRIPTION	SEAT POSITION NUMBER				
	1 (FPA Activated)	1 (FPA Deactivated)	2	3	4
Seating position suitable for lateral fixture (L1/L2)	NO	NO	X	X	X
Suitable rear-facing fixture (R1/R2/R3)	NO	NO	R1, R2	NO	R1, R2
Suitable front-facing fixture (F2X/F2/F3)	NO	NO	F2X, F2, F3	NO	F2X, F2, F3
Suitable booster fixture (B2/B3)	NO	NO	B2, B3	NO	B2, B3

### Key for the table:

YES = Suitable for the seating position description.

NO = Not suitable for this seating position.

X = ISOFIX (Lower Universal Anchorage System) position is not suitable for ISOFIX (Lower Universal Anchorage System) child restraint systems in this fixture.

FPA = Front Passenger Airbag.

### Child Seat Belt Fastening



**WARNING:** Seat belts are designed for adults, so infants and smaller children need to be restrained in an approved child safety seat. An infant or child that is not correctly restrained can be seriously injured or killed in a crash.

The upper webbing strap should be positioned across the child's rib cage and hips, keeping the child safe but comfortable. It is important the lap webbing strap is positioned across the thighs, bearing on the pelvis but not on the abdominal area.

The seat belt webbing should be positioned as advised, over the body parts that are most capable of taking force from any impact.

### Child Seat and Front Passenger Airbag



**WARNING:** Never put a child in a child seat or on a booster cushion on the front passenger seat if the airbag is set to on.



**WARNING:** Do not deactivate the front passenger airbag unless you are installing a child seat on the front passenger seat. Always activate the passenger airbag when the child seat is removed from the front passenger seat.



## BEFORE DRIVING

---

seat. Failure to switch on the front passenger airbag when used by an adult after the child seat has been removed will result in the occupant not receiving full protection of the airbag. Serious injuries or death could occur.

The airbag system is designed to deploy, to provide additional protection for the front seat occupants in serious frontal or side collisions.

### ISOFIX (LOWER UNIVERSAL ANCHORAGE SYSTEM) AND I-SIZE ANCHORS



**WARNING:** Always make sure the child seat is correctly secured in place according to the manufacturer's instructions. An unsecured child seat is dangerous. In a sudden stop or a collision it could move, causing serious injury or death to the child or any other passengers.



**WARNING:** Make sure the seat and anchor points are clear of items or obstructions, when installing the child seat. Failure to do this will prevent the child seat from being correctly and securely installed to the ISOFIX (Lower Universal Anchorage System) / i-Size ( International Standards Organisation FIX ) anchor points.



**WARNING:** If the child seat is not secured correctly to the ISOFIX (Lower Universal Anchorage System) / i-Size anchors then sudden braking or a collision could cause

the seat to move resulting in serious injury or death to the child or passengers.



**WARNING:** Make sure that the child seat tether strap is always used, when installing a child seat with ISOFIX (Lower Universal Anchorage System) / i-Size anchors.



### Rear Seat ISOFIX (Lower Universal Anchorage System) / i-Size

The vehicle is equipped with ISOFIX (Lower Universal Anchorage System) / i-Size anchors for the use of child seats on the rear

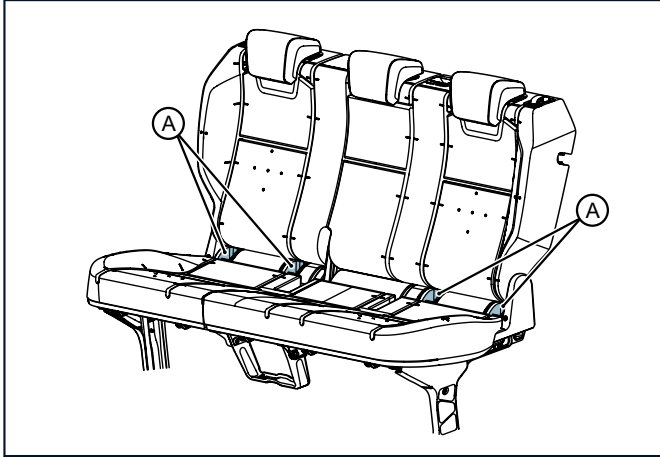

## BEFORE DRIVING

passenger seats. The anchor points (A) are located between the seat base and the seat back, in both the outer rear seats.





ISOFIX (LOWER UNIVERSAL ANCHORAGE SYSTEM)	i-SIZE
	

### Tether Anchor Points

-  **WARNING:** Always use the child seat tether strap when installing a child seat to ISOFIX (Lower Universal Anchorage System) / i-Size anchors.
-  **WARNING:** Child restraint anchor points are solely for securing children and child seats. Never use them for holding down or securing items. Adults should use the adult restraint systems provided. These anchor points are designed to withstand only the loads imposed by correctly installed child restraints.
-  **WARNING:** Adhere to the manufacturer's instructions for correct fitment and positioning of child seats to ensure safety. Failure to do so can be dangerous.

## BEFORE DRIVING

-  **WARNING:** The tether strap should always be free from obstructions. Do not place any items on the tether strap between the child and the tether anchor point. It is very important not to install the tether strap over the child. If the item or obstruction moves during travel, the tether strap can become loose and much less effective in a collision.
-  **WARNING:** Always ensure that any child seat installed is securely in place before travelling. An unsecured child seat could result in serious injury or even death.
-  **WARNING:** Make sure seat belts are moved out of the way when installing child seats to the ISOFIX (Lower Universal Anchorage System) / i-Size anchors and tether anchors. Otherwise it may prevent the child seat from being securely attached to the ISOFIX (Lower Universal Anchorage System) / i-Size anchors.

Tether straps are designed to minimize movement of a child seat during sudden braking or collisions. The tether strap links the top

section of the child seat to the tether anchor on the back of the rear seats.

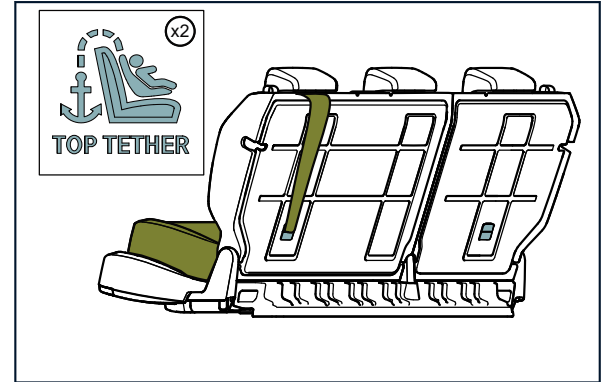

To secure the tether strap to the tether anchor at the back of the rear seats, ensure the strap runs between the headrest rods on top of the seat, resting beneath the headrest itself. Make sure there is no slack in the tether once attached.

The tether anchor points can be identified with the symbol .

# BEFORE DRIVING

## CHILD SEAT WITH SEAT BELT INSTALLATION



**WARNING:** Seat belt installed child restraints are designed to be secured by the lap belt and shoulder portion of the seat belt. If the child restraints are not properly secured then children could be at severe risk of injury or death in the event of sudden braking or a collision.



**WARNING:** When installing a child seat follow the manufacturers instructions for correct installation process. Not following the child seat manufacturers instructions when installing the child seat is dangerous and can lead to injury or death in sudden braking or in the event of collisions.

To install a child seat to the front seat using the seat belt, please follow the procedure provided:

1. The passenger airbag must be deactivated for the safety of the child.
2. Move the passenger seat rearward and recline the back of the seat to create space.
3. Follow the child seat manufacturer's instructions and install the child seat into the passenger seat. It is important to follow the manufacturer's instructions for the safety of the child using the child seat.
4. Adjust the back section of the passenger seat until the child seat is supported and secure.

The vehicle is installed with a Automatic Locking Retractor (ALR) system to secure child seats into place once installed. The ALR system will temporarily lock the seat belt to secure the child seat in place.

### Automatic Locking Retractor

The automatic locking retractor (ALR) system, is designed to only operate once the seat belt has been fully extended. Only when the seat belt has been pulled to the maximum extension point, should the belt be used, to secure the child seat.

Using the belt latch, thread the seat belt through the child seat correctly and engage the belt latch into the seat buckle.

Once the seat belt is engaged, it is important to gently remove the slack from the lower belt. Then allow the upper belt strap to retract, until there is no slack. When the upper belt is retracting you should hear a "clicking" sound as the seat belt retracts.



**WARNING:** Always check the child seat is secure after installation.



**WARNING:** Always pull on the upper seat belt strap after the belt has retracted, to check that the ALR lock has engaged.



**NOTE:** When parked on an incline, the seat belt may lock as it is withdrawn. This is not a fault. If the mechanism locks, release the seat belt tension and then pull the seat belt very gently to avoid operation of the inertia lock.

## BEFORE DRIVING

Upon removal of the child seat, the seat belt should be fully retracted into a disused position, doing this will disengage the ALR system to make the ALR system safe and ready for use by other adult occupants.

**i** *NOTE: Once the ALR system has been disengaged, it is important to always repeat the process, of fully extending the seat belt to re-engage the ALR system when reinstalling the child seat.*

### CHILD DOOR LOCKS

- !** **WARNING:** Use the child locks when children are occupying the rear seats.
- !** **WARNING:** The central locking function is NOT a child lock.

The vehicle's rear doors are equipped with child locks designed to prevent children from opening them from inside the vehicle. In

position (A), shown in the image below, the child locks are activated, while in position (B), they are deactivated.

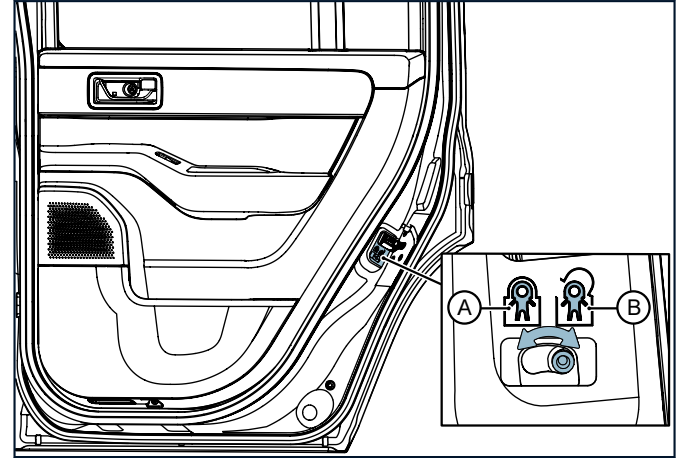

### ALCOHOL INTERLOCK (OPTIONAL)

The INEOS Grenadier can be equipped with an Alcohol Interlock (AI) as an optional extra. The function implementation is based on EN50436-4(2022) (European standard for ignition interlock devices).

## BEFORE DRIVING

---

The Alcohol Interlock (AI) is part of the immobiliser system. Therefore, a sample of breath will need to be taken before the driver can start the vehicle.

For further information regarding the Alcohol Interlock (AI), please scan the following QR Code:



Alternatively, visit the INEOS Grenadier website for more information:

<https://ineosgrenadier.com/>

# VEHICLE OPERATION

---

VEHICLE ENGINE RUNNING-IN .....	56
STARTING AND STOPPING THE ENGINE .....	56
WINDOWS AND MIRRORS .....	58
INTERIOR LAMPS .....	62
EXTERNAL LAMPS .....	64
WIPER AND WASHER SYSTEM (If Applicable) .....	70
HANDBRAKE .....	73
DRIVETRAIN .....	74
VEHICLE LOADING .....	84
FUELLING .....	87
PARTICULATE FILTERS .....	91

# VEHICLE OPERATION

## VEHICLE ENGINE RUNNING-IN

Proper running-in of both the petrol and diesel engine, is essential to ensure the best possible reliability of the engine and vehicle components throughout the vehicles life.

Driving with care during the initial 500 miles (800 km) is crucial to allow the engine, gearbox, brakes, and tires to properly bed-in. INEOS recommends the following for the running-in process:

- > Do not over stress or strain the engine in any gear.
- > Do not apply full throttle and avoid reving the engine beyond necessary levels.
- > Where possible, avoid fast acceleration and heavy braking. This does not apply in the event of emergencies.

**i** *NOTE: Fuel and engine oil consumption may be higher during running-in phase.*

**i** *NOTE: During the initial drive, smoke may emerge due to the evaporation of wax and oil from the exhaust system. If this occurs after the first drive, park the vehicle in a well-ventilated outdoor area and refrain from inhaling any fumes.*

## STARTING AND STOPPING THE ENGINE

### Ignition Position



**CAUTION: Do not hold the key in position (3), once the engine has started release the key immediately. Failure to do this may damage the vehicle components.**

1. Insert the key into the ignition barrel, position (1)
2. Turn the key clockwise again to switch on the ignition (IGN), position (2)
3. Turn the key clockwise again to start the engine, position (3)
4. After the engine has started, release the key to allow it to return to position (2).

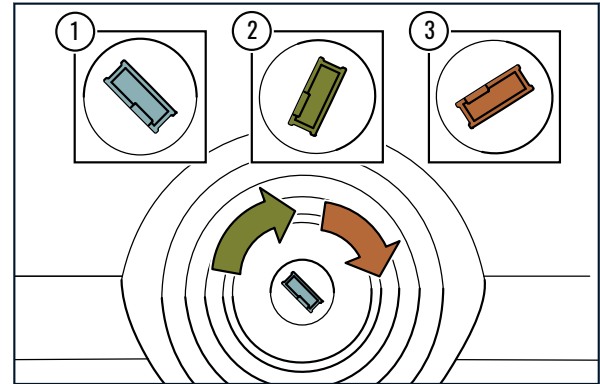



# VEHICLE OPERATION

## Starting the Engine



**WARNING:** The engine can be started by any person in the vehicle if the key is in the ignition. Care should be taken that the vehicle is not left unattended with the key present and occupants such as young children inside. The foot brake must be applied to start the engine. If the foot brake is not applied then the engine will not start.



**WARNING:** Make sure the handbrake is applied and the transmission is in park (P). This will prevent the vehicle from moving once the engine is started.



**CAUTION:** In extreme low temperatures (-20°C and below), do not run the engine above 4000 rpm, while at standstill or when moving off, until the coolant temperature gauge reaches normal operating temperature. If you do, there is a risk of damage to the engine.

Apply pressure to the brake pedal, turn the key to position (4) until engine starts. Once the engine has started, release the key. This will allow the key to rotate back to position (3).

## Switching Off the Engine



**WARNING:** Make sure the handbrake is applied and the vehicle is in Park (P) before switching off the engine. This

will prevent the vehicle from moving once the engine is started.

To switch off the engine, rotate the key to position 1 and remove the key.

## Eco Start / Stop (ESS)

ESS temporarily switches off the engine when the vehicle is stationary, such as, stopped at traffic lights or in traffic.

## Eco Start / Stop Operation (ESS)

The Eco Start/Stop function is on by default when the car is started.

ESS can be manually switched off by pressing the  button (10), located on the centre console.

The engine will switch off automatically, if the vehicle is in gear **D** and the brake pedal is applied when the vehicle is stationary. When the engine has stopped and the brake pedal is applied, the gear can be changed to **P** and the brake pedal can be released, the engine will stay in a stopped condition.

The engine will automatically restart after shifting into **D** and/or the brake pedal is released. The engine will also restart when:

- > Driver opens the drivers door and releases the drivers seat belt (Auto P will be engaged).
- > Gear selector is in position **N**, **R** or **M** (Manual).
- > Driver applies the accelerator pedal .

# VEHICLE OPERATION

- Oil level measurement is started.
- ESS button is pressed.
- Air condition management is changed.
- Vehicle rolling is detected.
- Time limit of 3 minutes, is reached.

Eco start/stop will deactivate if any or multiple of the situations below apply:

- Gear selector is in position **N**, **R** or **M** (Manual).
- Vehicle battery state of charge is below 50%.
- The vehicle is on a steep gradient.
- Brake pedal is not adequately applied.
- Drivers seat belt is not worn and drivers door is not properly closed.
- Bonnet is not properly closed.
- Engine, gearbox or battery is not up to optimal temperature.
- The Two-Speed Transfer Case is in Low Range.
- Off-road Mode or Wading Mode is active.
- The outside temperature is too low or high.
- A trailer is connected.

## WINDOWS AND MIRRORS

### Windows



**WARNING:** Window switches can be operated by all occupants. It is important that they are not misused in anyway. Drivers must advise all passengers, of the possible danger and make sure that all obstructions are clear before raising the window.



**WARNING:** It is important that when the windows are open, the occupants must keep their hands and arms inside the vehicle to avoid injury. It is also essential that items, such as, long objects or body limbs are not hanging out of the windows as this can cause serious injury or a crash.



**WARNING:** When transporting pets, it is important to check they can not reach the window opening and they are correctly restrained to avoid injury or an accident.



**NOTE:** It is recommended to apply a water repellent coating to the front door windows at regular intervals. This will help to clear water from the windows, improving driver vision.

The ignition must be set to on for the windows to operate. If the power is disrupted, such as, a battery disconnection or the ignition is turned off, then the windows will fail to operate as expected.

# VEHICLE OPERATION



*NOTE: The windows will continue to be powered up to sixty seconds after the ignition has been turned off.*

The driver and the passenger windows in both the front and back seating area are electrically operated by buttons in the doors. The driver window control panel consists of four switches to allow the driver to operate all windows. The switch to operate the passenger windows is a single switch in each of the passenger doors.

Press on the window switch until the window moves, then let go and the window will continue to open. You can stop this with another press on the switch.

To close the window, pull the window switch and hold until the window is closed. There is no 'one-touch, auto up' when closing the window.



*NOTE: No Anti-pinch function available.*

## Exterior Mirrors

The standard exterior mirrors are manually adjustable unless the optional Power Heated Exterior Mirrors are selected. The Power Heated Exterior Mirrors are electrically adjustable using the mirror control pad located on the driver door. Press the mirror switch left or right to select the side to adjust. Move the directional pad up, down, left or right to adjust the selected mirror.

## Folding Mirrors



**WARNING: Take care folding and unfolding the mirrors. Folding the mirrors with force can damage the vehicle.**



**WARNING: Do not drive with the mirrors folded, this will reduce visibility around the vehicle and can lead to a crash.**



**WARNING: After unfolding the mirrors, adjust the mirrors, to ensure visibility is good before driving. Failure to do this may result in a crash.**

The exterior mirrors can be folded manually, this should be done from outside of the vehicle.

## Power Heated Exterior Mirrors (OPTIONAL)

The heated door mirrors will automatically switch on and operate, when the heated rear window button  is pressed.

The heating will switch off automatically after 30 minutes.

## Interior Mirrors

The rear view mirror is attached to a ball mounting, this allowing the driver to adjust the position of the mirror.

The rear view mirror can be manually dimmed using the lever (1) positioned beneath the mirror. Push the lever towards the front of

## VEHICLE OPERATION

the vehicle for the mirror to appear dimmed, and returning to a non-dimmed position, by pulling the lever towards the back of the vehicle.

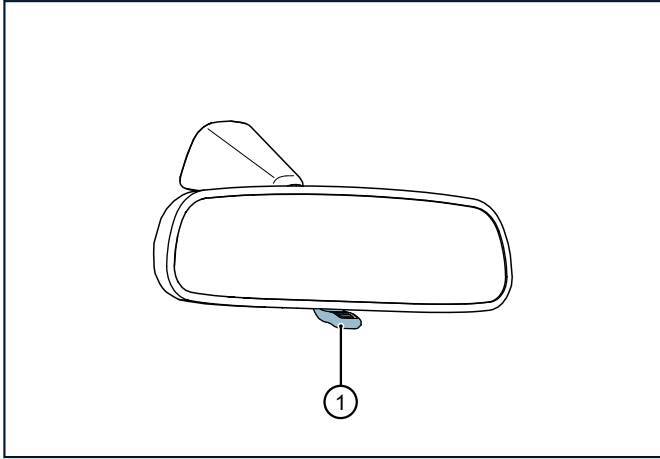

### SAFARI WINDOWS (OPTIONAL)

The safari windows are located in the roof of the vehicle. The safari windows can be partially opened to let air flow in and out of the vehicle in hot climates or when drying the interior after washing. The safari windows can be completely removed and stored in the vehicle.



**WARNING:** Do not operate the safari windows while driving.



**WARNING:** Make sure the mechanism is fully locked into place when the safari window is opened but not removed.



**WARNING:** Do not drop the safari windows on to hard surfaces. Always handle with care.



**WARNING:** Always firmly grip the safari windows and slowly guide the windows through the sunroof opening. Dropping or pulling the window through the opening quickly can result in damage to the vehicle or serious injury to the occupants.



**CAUTION:** It is important to close the safari windows in bad weather conditions to avoid water damage to the interior of the vehicle.



**CAUTION:** Never leave the safari windows partially open or fully removed when away from the vehicle.

To partially open the safari windows:

1. Push the latch mechanism towards the front of the vehicle.
2. Push the latch mechanism upwards, until the latch mechanism is firmly pushed and locked into place.

## VEHICLE OPERATION

To completely remove the safari windows, follow this procedure:

1. Partially open the safari windows.
2. Push the lower section of the locking mechanism upwards. Do this until the safari window and the lower section of the locking mechanism detach.
3. Push the safari window upwards until it is possible to direct the safari windows away from the front of the vehicle, freeing the brackets from the latch support.
4. The safari window should be held with a firm grip using two hands to guide it in through the opening.



*NOTE: Do not balance the window on the vehicle roof, in the process of detaching.*

### Safari Window Storage



**WARNING:** The storage bag must be secured adequately in the vehicle. Failure to do so may result in the bag moving around causing injury to occupants or damaging the vehicle.



**CAUTION:** Use the storage bag when moving or transporting the safari windows. Failure to do so may result in damage to the vehicle and to the safari windows.

There is a dedicated storage bag to safely store the safari windows in once they have been removed from the vehicle. The Bag must be secured to the tie down rings on the loadspace floor. Please see the following image:

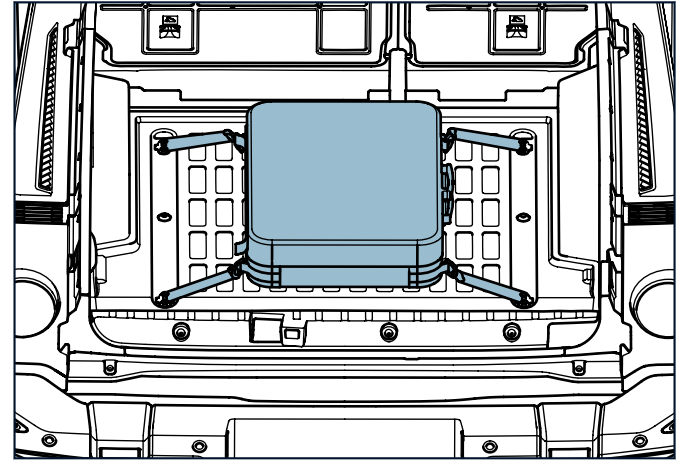

*NOTE: In the Station / Utility Wagon, the bag must be placed in the rear of the vehicle, strapped in using the lashing eyes to keep it secure and in place.*

In the Quartermaster, the bag must be placed on either of the two outboard seats of the rear bench in a portrait orientation with

## VEHICLE OPERATION

handles facing inward. The respective seat belt must be fed through both storage bag handles and locked into place.

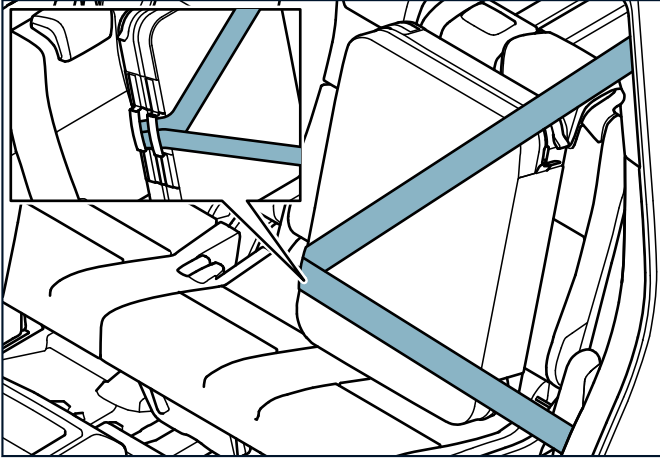

### INTERIOR LAMPS



**NOTE:** The interior lamp switch  is located on the roof console. The switch overrides the individual reading lamp switches and door ajar light switch.

Interior lamps include first row, second row reading lamps and foot-well lamps (if applicable).

A single press of the button will turn on the interior lamps. Press again to turn them off. When the interior lamps feature is switched on, a small LED lamp will illuminate on the button.

### First Row Reading Lamps

The first row reading lamps are located in the overhead control panel, between the driver and front passenger.

The reading lamps are equipped with individual switches. Single press the switch, to turn on the respective side of the reading lamp, and single press the switch, to turn off the reading lamp.



**NOTE:** If the following conditions are met, the reading lamps will remain illuminated even if the lamp switch position is off.



Interior lamp switch is turned on.



Courtesy lamp switch is set to auto and any door is open.

### Second Row Reading Lamps

Each reading lamp is equipped with individual switching buttons, marked by a diamond texture.

Single press the switch, to turn on the respective side of the reading lamp and single press the switch to turn off the reading lamp.

# VEHICLE OPERATION

The switch bezel swivels on the hinge, at middle of the bezel. Only one side of the lamp can be pressed at one time.

## Ambient Lamps

LAMP	MOUNTING LOCATION	STANDARD / OPTIONAL
Overhead Console Lamp	Overhead Control Panel	Standard
Glovebox Lamp	Glovebox	Standard
Foot-well Lamp	Under Instrument Panel	Standard
Ambient Door Lamp	Door Interior Trim	Optional

The overhead console lamp and the ambient door lamps (if applicable) will illuminate, in the following conditions:

- > Low beams are switched on
- > High beams are switched on
- > Headlamps are set to AUTO.

The glovebox lamp, will illuminate when opened, or deactivated when closed.

The foot-well lamps will illuminate, if the interior lamp button  is on, or if the courtesy lamp function is activated. The courtesy lamp function is activated, if the doors are opened, key is used to unlock the doors or the ignition is turned off.

## Puddle Lamps (OPTIONAL)

The vehicle may have puddle lamps installed.

If a door is opened, then the respective puddle lamp will automatically switch on. If the door is closed, then door puddle lamp will switch off.

Puddle lamps will switch off after ten minutes, if a door is left open and the ignition is off.

## Loadspace Lamps (Station / Utility Wagon Only)

The Loadspace Lamp is located in the headliner, at the back of the vehicle.

The Loadspace Lamp will illuminate when the Rear 30/70 Doors are opened. The Loadspace Lamp will extinguish when the Rear 30/70 Doors are closed.

## Courtesy Lamps



*NOTE: Door ajar lamps (courtesy lamps) are independent of reading lamp switches and the interior lamp switch.*



*NOTE: Door ajar lamps are automatically on if the doors are opened, even though the reading lamp switches or the interior lamp switches are set to off.*

Door ajar includes first row, second row reading lamps and foot-well lamps.

# VEHICLE OPERATION

All lights are turned on/off simultaneously, however the function is automatic if the door ajar switch is set to on and a door is opened.

## EXTERNAL LAMPS

All external lamps are sealed lamp units with light-emitting diodes (LED) as the light source. The lamp units are not repairable. If a lamp or lamp unit fails, contact your INEOS approved partner.

### Low Beam

The low beam is for use at night in areas illuminated by street lamps, such as towns and cities or when driving in low visibility weather conditions. The low beam uses an asymmetrical beam to illuminate a shorter distance of the road ahead compared to high beam to avoid the blinding of oncoming vehicles.

To switch on the low beam, rotate the end of the left lever stalk to position 3. To switch off the low beam, rotate the end of the lever stalk back to the 'OFF' position; Position 1.

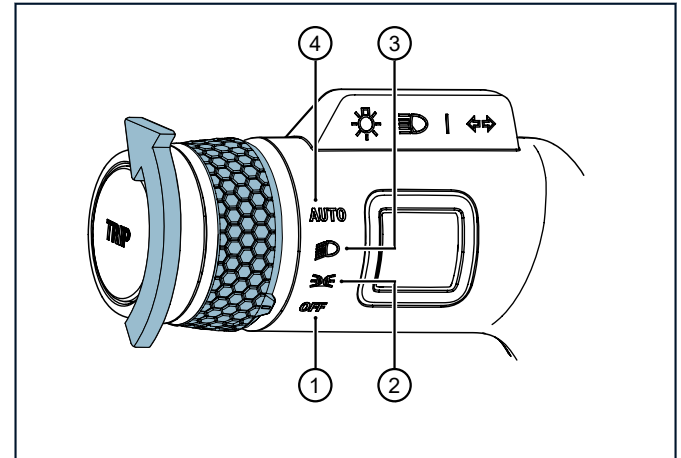

POSITION	STATUS	DEFINITION
1	OFF	Low beam lamp functions are switched off
2	Side Marker Lamps	Side marker lamps are active.



# VEHICLE OPERATION

POSITION	STATUS	DEFINITION
3	Low Beam	Low beam is activated
4	AUTO	Switches low beam on automatically, when the sensors detect low enough ambient light to switch lamps on.

## Side Marker Lamps



**CAUTION:** Leaving the side marker lamps on while the engine is switched off, will drain the battery and should only be used for a limited period of time.

To switch on the side marker lamps, rotate the end of the left lever stalk to position 2. It is recommended that the side marker lamps are used when parking on the side of the road at night, or when visibility is first effected by the weather.

## Auto Light Control

When the automatic light control function is switched on and the engine is running, the system switches between daytime running lamps and low beam headlamps automatically. This depends on the external lighting conditions and the information given by the sensor system. When entering and leaving a tunnel for example, the low beam headlamps will automatically turn on when there is minimal

day light. They will turn off again when leaving the tunnel and the sensors recognise good daylight.

To switch on the automatic light control function rotate the end of the left lever stalk to position 4.

The auto function switches between daytime running lamps to the following functions:

- > Lamps front and rear on.
- > Side marker lamps front and rear on.
- > Low beams on.
- > License plate lamps on.

## High Beam



**WARNING:** If switched on with nearby traffic or oncoming traffic, switch the high beam to low beam to avoid dazzling other drivers. There is a risk of an accident if the oncoming drivers are temporarily blinded.

The high beam is used to illuminate the road at night when there is no street lamps or if the vehicle is being used in a situation with no lighting such as driving off-road at night.

## VEHICLE OPERATION

To switch on the high beam, push the left lever stalk away from the driver, towards the front of the vehicle. To switch off the high beam pull the lever stalk towards the driver back into the starting position.

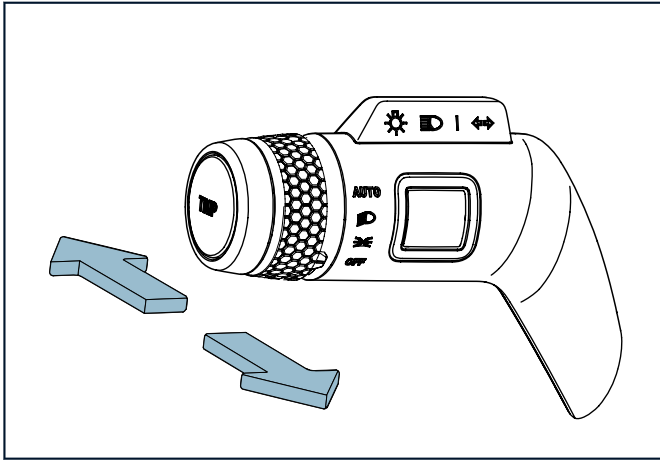

### High Beam Flash

To flash the headlight pull the left lever stalk towards the driver to activate the headlight and then release back to the starting position to deactivate the headlight. This will result in the headlight flashing on and off once. Repeat for consecutive flashes of the headlights.

### Daytime Running Lamps

Daytime running lamps, increase visibility of the vehicle during daylight. They are switched on automatically during the daytime, when the engine is running. The system can switch between daytime running lamps and headlamps automatically, depending on the lighting conditions.

### Direction Indicators

To briefly indicate, push the left lever stalk upwards or downwards and release. To indicate continuously push the left lever stalk upwards or downwards, until the left lever stalk latches into position,

# VEHICLE OPERATION

giving an indication signal. To cancel, move the lever stalk back to the starting position.

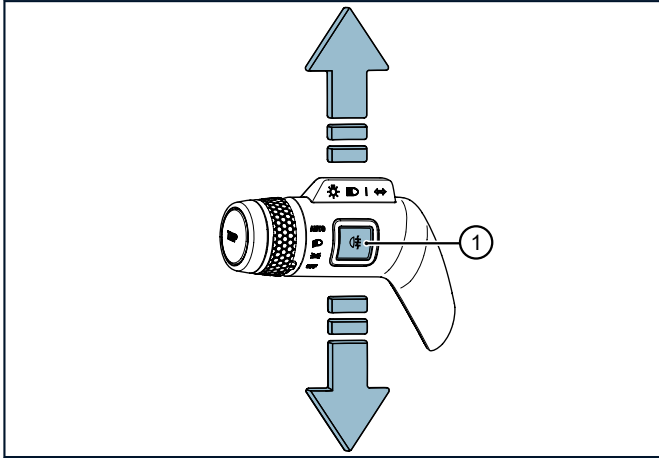

## Rear Fog Lamps



**WARNING:** Remember to switch off the rear fog lamp when the function is not necessary as this can blind or distract other drivers.

The rear fog lamps  are operated by pressing button (1) on the stalk.

The rear fog lamp is for use in fog or other adverse weather conditions with low visibility.

## Hazard Lamps



*NOTE: When the ignition is switched off, the hazard warning lamps will continue to operate.*

Press the hazard warning lamp button (13), located on the centre console, to activate the hazard warning lamps.

## VEHICLE OPERATION

When the hazard warning lamps are switched on, all direction indicator signals will blink. Press the button (13) again, to switch the hazard warning lamps off.

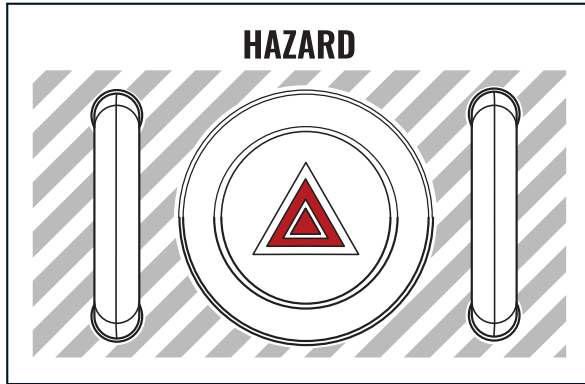



### Reverse Lamps

When the ignition is set to on and the reverse gear is selected, the reverse lamps will illuminate.

### LED Auxiliary High Beam Lights

The LED Auxiliary High Beam Lights, also known as the working lamps, are additional headlamps that can only be activated with the high beam switched on. To operate the lamps, the ignition first needs

to be on and the  button located in the overhead control panel should be then pressed, which will illuminate to notify the driver that the lamps are primed.

-  **NOTE:** The lamps will have the same effects as the high beam which will create glare to oncoming traffic.
-  **NOTE:** The use of the LED Auxiliary High Beam Lights are strictly for off-road purposes only. LED Auxiliary High Beam Lights could temporarily blind other road users.

### Headlamp Range Adjustment

-  **WARNING:** It is important to adjust the headlamp range, dependent on the weight distribution within the vehicle. Failure to adjust the headlamp range, may temporarily blind other road users.

The distribution of the weight in the vehicle, effects the height of the headlamp beams. Always adjust the headlamps to maintain adequate illumination of the road and space in front of the vehicle, without dazzling other drivers and road users. Turn the thumb wheel

 located in the roof console, to the required switch position.

## VEHICLE OPERATION

POSITION	LOAD
0	Driver only, or driver and all front seats occupied (load-space empty)
1	All seats occupied (load-space empty)
2	All seats occupied by adults (load-space at maximum)
3	Driver only (load-space at maximum)

### Quartermaster Loadbay Lamp (OPTIONAL)



**WARNING:** It is NOT legal to drive the vehicle with the Loadbay Lamp illuminated. The Loadbay Lamp MUST be switched OFF, before moving the vehicle. Check local laws and regulations.

To activate the Quartermaster Loadbay Lamp, follow this procedure:

1. Switch the vehicle ignition ON
2. Switch the PWR button located in the Overhead Console to ON
3. Touch the white lens area of the Loadbay Lamp with your hand for 2 seconds.

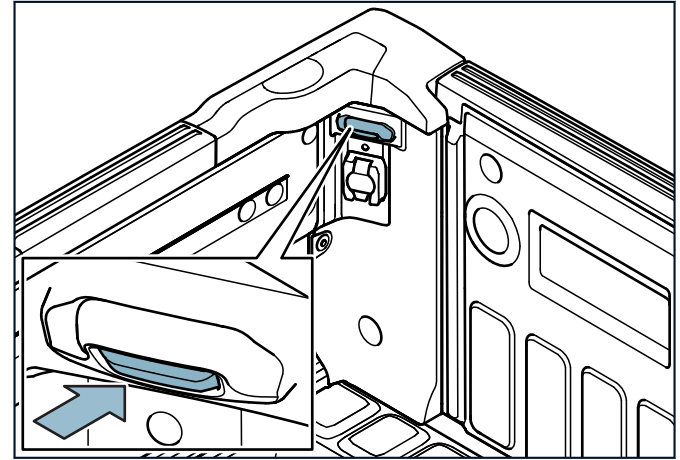

To deactivate the Quartermaster Loadbay Lamp, follow this procedure:

1. Touch the illuminated lens of the Loadbay Lamp with your hand for more than 1 second.
2. Switch OFF the PWR button located in the Overhead Console.



**NOTE:** If the Loadbay Lamp is not switched off manually, it may automatically switch OFF after 60 minutes.

## VEHICLE OPERATION

- i** *NOTE: The Loadbay Lamp's capacitive sensor, is designed to minimise the risk of the lamp turning ON from self capacitance during rain and water wash, although, it's not guaranteed to work in all user cases.*
- i** *NOTE: Wipe any excess water from the white lens surface and ensure hands are dry when switching ON or OFF the Loadbay Lamp.*
- i** *NOTE: If the supply battery voltage drops below 10v, elevates above 16v or the engine is cranked, then the Loadbay Lamp may switch OFF automatically.*
- i** *NOTE: Clear the Loadbay Lamp of dirt, debris and/or ice, before touching to switch ON or OFF the Loadbay Lamp.*
- i** *NOTE: Gloves must be removed before switching ON or OFF the Loadbay Lamp.*

\* Not applicable to the Double Cab Chassis.

### WIPER AND WASHER SYSTEM (If Applicable)

The wiper and washer system ensures clear visibility by removing raindrops from the windscreen and rear window glass during rainy

conditions. When combined with the washer system, it effectively clears dirt and dust from the windscreen. This system is crucial for safe driving, as it maintains optimal visibility on the road.

### Windscreen Wiper

The steering column stalk manages the wipers, wash, and wipe function. To toggle the front wiper modes, push the stalk up or pull the stalk down.

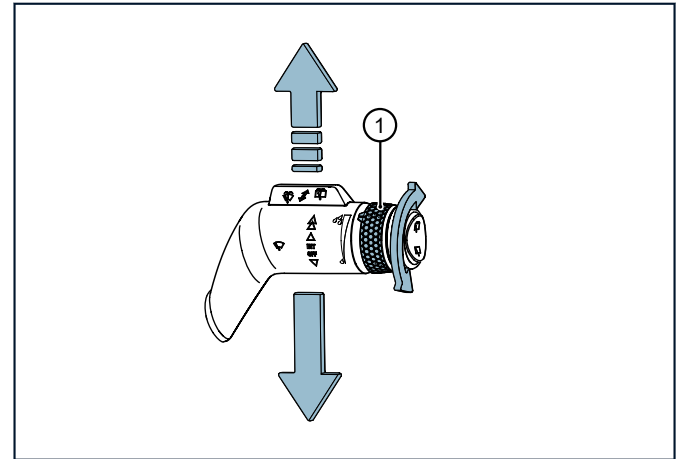

## VEHICLE OPERATION

---

MODES	DEFINITION
OFF	To switch off the front wipers, pull the stalk to its lowest resting position.
QUICK WIPE	A brief push down of the stalk from the off position activates a single sweep of the wipers, returning to the off position upon release.
INTERMITTENT	Push the stalk up one click to activate intermittent wiper mode. Adjust the intermittent sweep speed using the rotary selector (1). Twisting the selector away from the driver increases the speed, while twisting towards the driver decreases it.
LOW SPEED	Push the stalk up twice from the off position to activate low-speed continuous wiper mode.
HIGH SPEED	Push the stalk up one click from low speed, two clicks from intermittent, or three clicks from off to activate high-speed continuous wiper mode.



**CAUTION:** When entering a car wash or during pressure washing, ensure the ignition is set to "on" and the wipers are switched off. This ensures the wiper arms are locked into the park position, helping prevent damage to them.

# VEHICLE OPERATION

## Rear Window Wiper (If Applicable)

The rear wiper is operated using a three-position toggle button located at the end of the stalk.

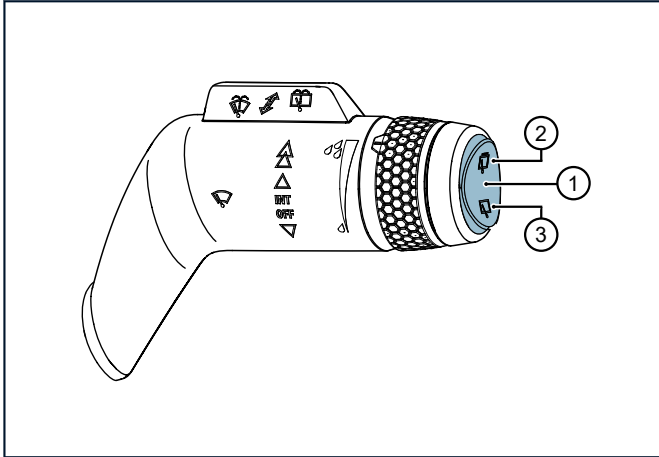

BUTTON	SPEED DESCRIPTION
2	To activate intermittent wiper mode, press the top button (2) until it aligns flush with the end of the stalk.
3	To engage continuous wiper mode, push the bottom of the button until it aligns flush with the end of the stalk.

BUTTON	SPEED DESCRIPTION
1	To switch off the wiper, ensure both the top (2) and bottom (3) of the switch are protruding from the end of the stalk.



# VEHICLE OPERATION

## Windscreen Washers

The wash and wipe is controlled by pushing the stalk away from, or pulling towards, the driver.

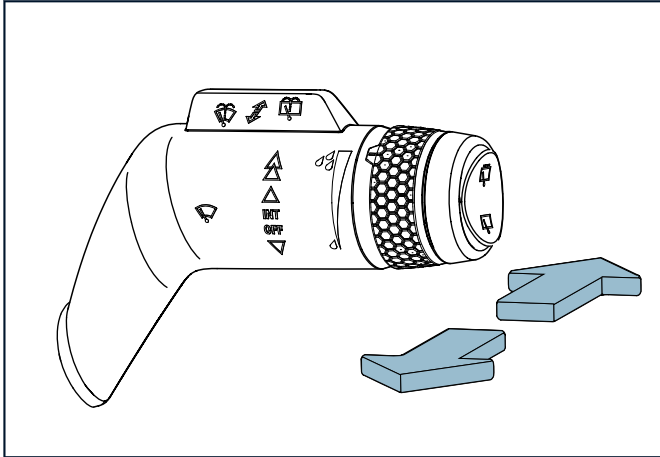

Pushing the stalk away from the driver temporarily, will activate the rear washer (if applicable) and the rear wiper (if applicable) will perform a continuous sweep for a set amount of time. Pulling the Stalk towards the driver temporarily will activate the front washers and the wipers will perform a low speed sweep for a set amount of time.

The stalk will return to the resting position as soon as it is released.

## Heated Windscreen Washer Jets (OPTIONAL)

The washer nozzles automatically heat up in cold weather to prevent the washer fluid from freezing. They can also be manually activated using the heated rear window button .

## HANDBRAKE



**WARNING:** When parking the vehicle, the brake pedal must be fully applied and it is essential that the gearbox is placed in the parking position (P). Then the handbrake should be applied to hold the vehicle in position. Do not leave the vehicle on a slope without completing these two steps. Not following this instruction may result in injury or death.



**CAUTION:** Do not apply the handbrake until the vehicle has stopped completely. Applying the handbrake lever while the vehicle is moving will lock the rear brakes and can make the vehicle unstable or result in the malfunction of the handbrake.



**CAUTION:** While driving, the hand brake lever must be fully released, otherwise the brakes may overheat resulting in damage to the vehicle.

# VEHICLE OPERATION

To release:

1. Firmly press and hold the brake pedal.
2. Pull the handbrake lever slightly up.
3. Press the button at the end of the handbrake grip.
4. Lower the hand brake lever completely.

To apply:

1. Bring the vehicle to a complete stop before applying the handbrake.
2. Firmly press and hold the brake pedal.
3. Pull the hand brake lever as far as possible without pressing the button at the end of the handbrake grip.

Pull the handbrake lever sufficiently to hold the vehicle stationary at a complete stop after releasing the brake pedal. Depending on the gradient and payload, the handbrake lever must be pulled further and the gearbox needs to be placed in the parking position (P). If the handbrake does not hold the vehicle stationary after the brake pedal is released, then the vehicle must be checked by an INEOS approved partner.

## DRIVETRAIN

The drivetrain transfers power generated by the engine to the wheels. Thus, providing the torque for your vehicle to move forward or in reverse.

## Automatic Transmission

The Grenadier's transmission combines the functions of an automatic transmission with the possibility of manual shifting.

The vehicle uses an eight - speed automatic gearbox and a Two-Speed Transfer Case. Using a Two-Speed Transfer Case allows for eighteen gears: sixteen forward and two reverse. The Two-Speed Transfer Case also has a centre differential, which distributes the drive to both the front and rear axles, providing permanent four-wheel drive.

## Gear Selector Positions

The gear selector is used to switch between the transmission modes.

The gear selector engages one of the following:

SYMBOL	GEAR	DEFINITION
<b>P</b>	Park	The transmission is locked into a parked position and unable to move or roll. Only select park <b>P</b> when the vehicle is not moving or rolling.
<b>R</b>	Reverse	Only select reverse <b>R</b> when the vehicle is stationary.
<b>N</b>	Neutral	The vehicle may be pushed to roll without power.*

# VEHICLE OPERATION

SYMBOL	GEAR	DEFINITION
D	Drive	All gears for forward travel are selected automatically.

Park is engaged automatically when:

- > The driver seat belt is unbuckled.
- > The drivers door is not shut correctly.
- > The engine is switched off and the transmission is still in drive or reverse.

\* - Do not push or roll excessively, this may result in damage to the two-speed transfer case and/or other vehicle components.

## Gear Selection



**WARNING:** Maintain pressure on the brake pedal to prevent the vehicle from moving, after you select a gear position.

To operate the gear selector, follow this process:

1. Make sure the driver seat belt is fastened.
2. Press and hold the button to release the selector lever lock.

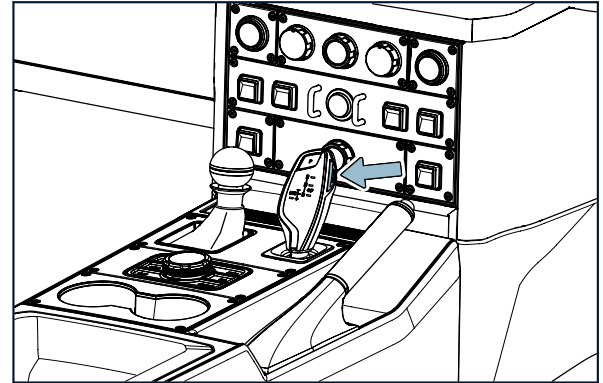

3. Push the selector lever in the desired direction. The selector lever automatically returns to the centre position when released.

## VEHICLE OPERATION

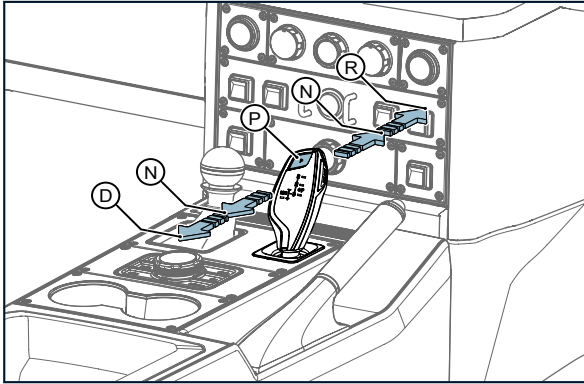

**i** *NOTE: Engage reverse, only when the vehicle is stationary.*

### Car Wash Function

The process below puts the vehicle into a state for safe rolling.

1. Put the transmission into **N** while pushing the brake pedal.
2. Stop the engine.
3. Immediately turn on the ignition without starting the engine.
4. Now "car wash function" is engaged and the vehicle can be pushed.

**i** *NOTE: If the ignition is not switched on the Park position will be engaged after several minutes.*

If there is a malfunction, you may not be able to change the gears. If this happens call the nearest INEOS approved partner for support.

### Activating Manual (Mode) and Shifting

**!** **WARNING: Do not allow the engine to rev too high and/or to sit on the rev limiter, for a period of time. If the vehicle revs on the limiter for a period of time, then you risk overheating and potential component failure. This will result in the need for recovery to an INEOS approved partner.**

The 8 - speed gearbox is automatic, but the driver can switch to manual mode. It may be necessary to switch to manual mode when driving down a steep hill.

# VEHICLE OPERATION

To activate manual mode, please follow the procedure below:

1. Push the gear lever to the left from gear lever position **D**.

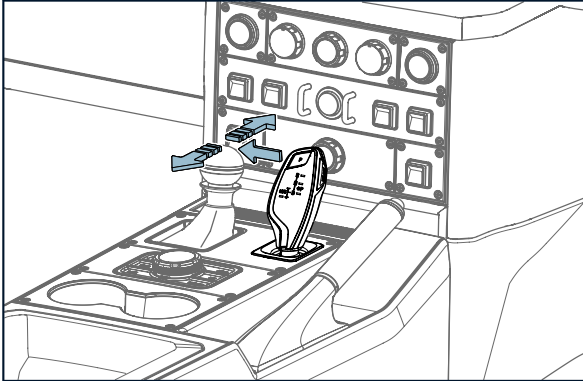

2. Use the gear selector to manually change gears:

- > To shift down, press the gear selector forward.
- > To shift up, pull the gear selector rearwards.

**i** *NOTE: The transmission will shift automatically in certain situations. For example, when the Revolutions Per Minute (RPM) threshold is reached.*

To exit manual mode, push the gear selector back to position **D**.

## Gear Shift Indicator

The gear shift indicator is designed to help reduce fuel consumption by recommending the most suitable gear.

Depending on the driving situation and the vehicle's equipment, the system may recommend skipping one or more gears. The condition of the road, the traffic density and safety should remain determining factors when choosing the best gear. Therefore, the driver remains responsible for selecting the correct gear for a given situation.

**i** *NOTE: The system cannot be deactivated while in manual operation mode.*

The information is shown on the infotainment screen in the form of an arrow and the recommended gear. This is located next to the fuel level gauge.

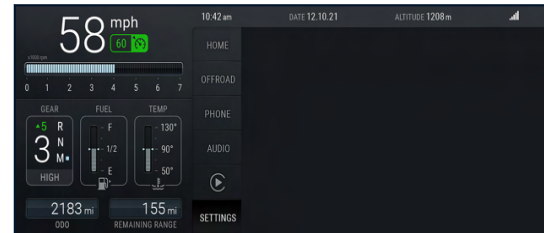

**i** *NOTE: The system adapts the gear change instructions according to the driving conditions. For example, slope*

## VEHICLE OPERATION

*or load and driving style, such as, power demand, acceleration and braking.*

### Two-Speed Transfer Case

The two-speed transfer case is designed to aid the driver when off-road driving or towing. The two-speed transfer case receives power from the transmission and sends it to both the front and rear axles. The positions are 'High', 'High Lock', 'Low' or 'Low Lock'.

### Engaging Transfer Case Selector Positions



**WARNING:** Low range should be used for off-roading or when wading. The low range gears should not be used on public roads.

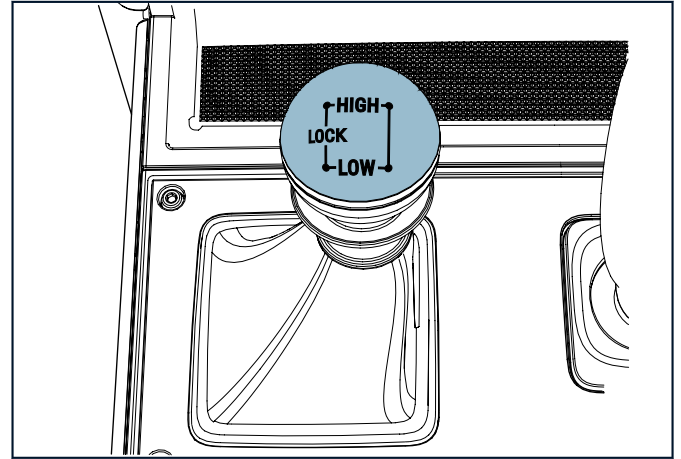

## VEHICLE OPERATION

The Two-Speed Transfer Case selector has a locking ring that must be pulled upwards before a different position can be selected.

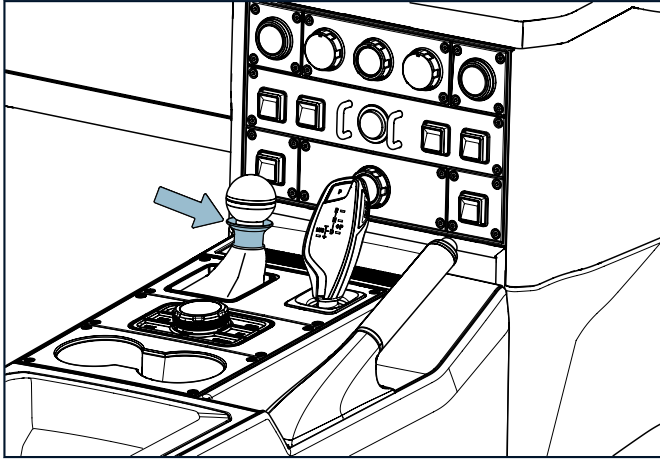





The Two-Speed Transfer Case selector engages the following:

**HIGH** - High range is used for all normal road driving and for off-road driving across dry, level terrain.

**LOW** - Low range should be used for pulling off from a stopped position with a heavy load, manoeuvring at low speeds with a trailer

or driving over challenging terrain at low speeds. Do not use 'LOW' on public roads.

To switch between the 'HIGH' and 'LOW', the vehicle needs to be stationary and the transmission must be in **N**.

-  **WARNING:** Maintain pressure on the brake pedal, to prevent the vehicle from moving after you select a gear position.
-  **CAUTION:** Ensure that the Two-Speed Transfer Case selector is fully engaged in either high range or low range, before selecting drive on the gear selector.
-  **WARNING:** Do not screw the 'neutral screw' on the Two-Speed Transfer Case anti-clockwise, unless the vehicle is already in a neutral state and you are putting the vehicle back into a drive state. If the screw is rotated the wrong way or removed, then this WILL result in severe damage to the Two-Speed Transfer Case.
-  **CAUTION:** Do not use pneumatic tools or electric tools on the 'neutral screw'. The 'neutral screw' must be rotated carefully.
-  **CAUTION:** This is an emergency neutral, for recovery and towing purposes only.

The Two-Speed Transfer Case can be put into neutral, in order to tow or roll the vehicle. If the engine is running then the automatic transmission must be in neutral. First, the vehicle must be secured

## VEHICLE OPERATION

with chocks, this will stop the vehicle rolling. Lift the collar on the Two-Speed Transfer Case selector and shift to a midpoint, between low and high range. Note that the selector will not lock into place. Next, underneath the vehicle the 'neutral screw' can be found on the Two-Speed Transfer Case. The screw must be rotated clock-wise, screwing inwards until it can't go any further. Once the screw has been screwed in as far as possible, the vehicle will be in a neutral state.

The 'neutral screw' can be identified by the word 'NEUTRAL' and a directional arrow, both visible on the Two-Speed Transfer Case. This will confirm the clockwise rotation, to achieve the neutral status of the vehicle.

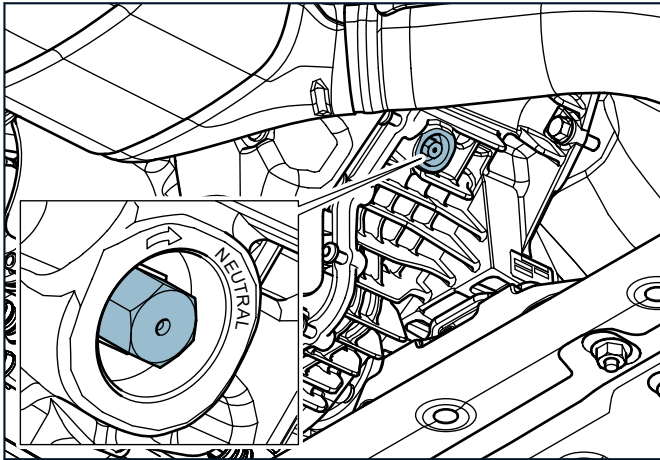

**WARNING:** When removing the vehicle from neutral after towing or rolling, it is important that the screw is rotated anti-clockwise, but only until the screw head is flat and flush with the Two-Speed Transfer Case. Any more than this will result in severe damage to the Two-Speed Transfer Case.

### Differentials



**WARNING:** Inappropriate operation and usage of the differential can be dangerous. This can result in component failure and damage to the vehicle, even injury or death, if a major component fails.



**WARNING:** Locked differentials can cause instability on high traction surfaces. This can cause an incident where the vehicle is damaged or injury is sustained.



**WARNING:** Never lock the front differential on a descent. Vehicle handling can be significantly reduced. It is dangerous and can lead to an accident or injury.



**WARNING:** It is possible to drive the vehicle up to 43 mph (70 km/h) while the differentials are engaged. Caution must be exercised as stability functions are NOT active with the differentials engaged. Failure to take caution can result in damage to the vehicle, injury or even death.



# VEHICLE OPERATION



**CAUTION:** With the differential locks engaged, acute turning angles can strain the drive line on high traction surfaces. This will put stress on components and may result in damage to the vehicle.



**CAUTION:** Only use the differential lock on low traction surfaces such as snow, sand or mud.



**CAUTION:** If the vehicle is driven on normal road surfaces with a differential locked, the steering will feel stiff, the tyres wear excessively and transmission 'wind up' will occur. This puts the transmission under excessive strain and can cause premature failure, which may not be covered by warranty.



**CAUTION:** If required, the differential locks must be engaged before proceeding to tackle an obstacle. Disengage the differential locks immediately after overcoming the obstacle. Long-term use may lead to thermal overload and permanent damage to the system.



**NOTE:** *It is recommended, that only trained or competent drivers should use the differential locks.*

## Permanent 4x4

Permanent 4x4 is a system that powers all four wheels at all times and it can be used full time on all surfaces including paved roads/high traction surfaces. The additional feature of a differential incorporated into the transfer case makes it possible to use 4WD all

the time. Each tyre has about 25% of the available torque, when the ground is level with a uniform surface.

## Centre Differential Lock



**CAUTION:** The differential should only be locked when operating the vehicle on low traction surfaces. Locking the differential on high traction surfaces can strain the drive line components.



**WARNING:** None of the differentials should be locked on high traction surfaces. A locked differential will severely impact the driving dynamics on high traction surfaces, making the vehicle unstable and dangerous to drive. This could result in an accident, serious injury or loss of life.

The vehicle is fitted with a lockable centre differential, which is selected by the transfer case selector. When the differential is unlocked, it allows the two axles to run at different speeds to meet the requirements of each axle. For example, when turning.

With an open centre differential, if a single wheel on either the front or rear axle loses traction, the ability for any of the wheels on the vehicle to transfer drive to the road surface, will be severely reduced or lost completely.

Locking the centre differential will distribute torque evenly to the front and rear axle at all times, meaning if a single wheel loses traction, it will only limit the ability of the respective axle to transfer drive to the road. The other vehicle axle will not be affected. On low traction surfaces, locking the centre differential can often improve

# VEHICLE OPERATION

the vehicle's ability to transfer drive to the surface and improve the overall vehicle traction.

## Lockable Rear and Front Differentials (OPTIONAL)



**WARNING:** When the front differential is locked, the steering possibilities of the vehicle are heavily limited.

The driver can lock the rear and front differentials from inside the cabin.

When a differential is locked, both wheels on the affected axle will rotate at the same speed for improved traction on difficult driving surfaces.



*NOTE: When the rear and/or front differentials are locked, the Electronic Stability Control and Anti-locking Brake System are automatically disabled.*

## How to Lock the Rear and Front Differentials



**WARNING:** Do not engage the rear and front differential locks, if one or more wheels are spinning, as this can damage the transmission.



**CAUTION:** The differentials must only be locked when driving off-road on loose and slippery surfaces. Always unlock the differentials for normal road driving or as soon as a non-slippery surface is reached, even if low

gears are selected on the transfer case. If you do not, the steering will feel stiff, the tyres will wear excessively and transmission wind-up will occur, which can cause damage to the transmission.



**CAUTION:** If the differential lock tell-tale is illuminated orange then this means the differentials are engaged. If the tell-tale is blinking on and off orange, then this means the differentials are engaging. If there is an error, then the tell-tale will illuminate red. If the tell-tale is illuminated red consult with your INEOS approved partner.

The rear and front differentials, are locked and unlocked, with two buttons in the overhead control panel. Both, the rear  and front

## VEHICLE OPERATION

 differential buttons, have a small LED which will illuminate, when the differentials are engaged.

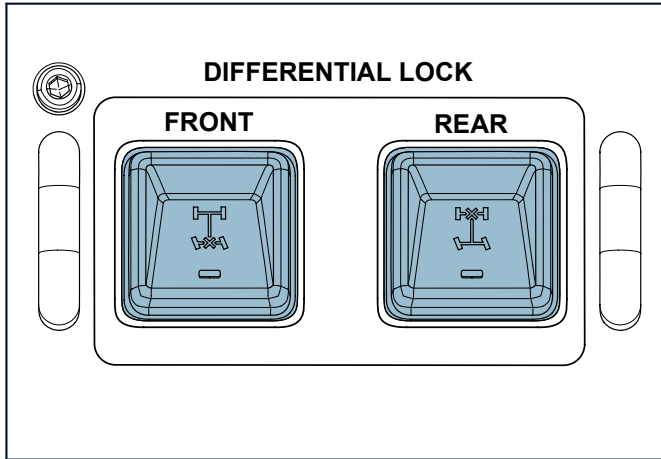

Differential Lock Sequence:

1. Transfer Case in 'LOW LOCK' Position.
2. Rear Differential Lock.
3. Front Differential Lock.

To lock the rear differential, press and hold the rear differential lock button for one second while following the listed conditions:

- > Engine running.
- > Transfer Case in 'LOW LOCK' position.
- > Speed below 9 mph (15 km/h).
- > Accelerator pedal application below 40%.
- > No spinning wheels.
- > The Electronic Stability Control system must not be actively supporting the driver, when switching on the differentials.



*NOTE: If the vehicle is stationary and you press the rear differential lock button for one second, the LED on the rear differential lock button will flash. As you start to move the vehicle, the differential lock status will be visible on the tell-tale cluster.*

To lock the front differential, press and hold the front differential lock button for one second while following the listed conditions:

- > Engine running.
- > Transfer Case in 'LOW LOCK' position.
- > Speed below 9 mph (15 km/h).
- > Rear differential lock engaged.
- > No spinning wheels.

## VEHICLE OPERATION

> The Electronic Stability Control system must not be actively supporting the driver, when switching on the differentials.

 *NOTE: If the front differential lock button is pressed before the rear differential lock has been engaged, then the button LED will flash once and the front differential lock will not engage.*

 *NOTE: If the vehicle is stationary and the rear differential lock has already been engaged. You can press the front differential lock button for one second, the LED on the front differential lock button will flash. As you start to move the vehicle, the differential lock status will be visible on the tell-tale cluster.*

To unlock the front or rear differential a short button press is needed. This can be done in any driving condition.

If you disengage the rear differential lock before you disengage the front differential lock, then both the front and rear differentials will be disengaged.

 *NOTE: If you disengage the centre differential lock before you disengage the rear and front differential lock, then all three differentials will be disengaged.*

When unlocking the front and rear differential locks the vehicle operates a state check. The vehicle uses the wheel speed sensors to determine if the wheels across an axle are rotating at different speeds and thus proving the differential has unlocked. The check may take some time as it depends on the current vehicle movement

to detect the correct state. Driving at low speeds while steering the vehicle left and then to the right, may reduce the state detection time.

### VEHICLE LOADING



**WARNING:** If loading large items or heavy items, take care and do this with the help of multiple people. It is also advised that the appropriate loading equipment is used where possible to avoid injury or death.



**WARNING:** Loading the vehicle with heavy items can change the handling characteristics of the vehicle. Take care when driving with a heavy load.



**WARNING:** Ensure that loads are secured into place when transporting heavy loads. It is dangerous to drive the vehicle with heavy loads moving around while in transit.

### Exterior Utility Belt (OPTIONAL)



**WARNING:** The Exterior Utility Belt (and any items attached to it) can only be used when off-road. On-road use is prohibited. Loading equipment on the exterior of the vehicle may change the handling characteristics. Users should not load the vehicle, any options or accessories (or any part of them) beyond their intended

# VEHICLE OPERATION

capacities. Improper use of the vehicle or other equipment may be unsafe and could result in property damage and/or injury to users and/or other parties.

The Exterior Utility Belt is positioned on the vehicle doors and for the station / utility wagon, under the third row window or panel. It is supplied with four Quick Release Tie-Down Rings, which slot into the pre-defined locations along the belt.

LOAD PER HOOK			
UPPER UTILITY RAIL		LOWER UTILITY HOOKS	
Front Door	10 kg (22 lbs)	Front Door	5 kg (11 lbs)
Rear Door	15 kg (33 lbs)	Rear Door	10 kg (22 lbs)
Rear Quarter Panel <sup>Q</sup>	15 kg	N/A	N/A

TOTAL LOAD PER RAIL / TETHERING HOOK (DOOR)			
UPPER UTILITY RAIL		LOWER UTILITY HOOKS	
Front Door	45 kg (99 lbs)	Front Door	15 kg (33 lbs)
Rear Door	35 kg (77 lbs)	Rear Door	20 kg (44 lbs)
Rear Quarter Panel <sup>Q</sup>	40 kg (88 lbs)	N/A	N/A

Q - Not applicable to the Quartermaster.

## Interior Utility Rails & Loadbay Utility Rails (OPTIONAL)



**WARNING:** Ensure equipment in the load space is secure, users should not load the vehicle, any options or accessories (or any part of them) beyond their intended capacities. Improper use of the vehicle or other equipment may be unsafe and could result in property damage and/or injury to users and/or other parties.

The Interior Utility Rails are located on the loadspace floor of the Station / Utility Wagon. The Load Bay Utility Rails are located in the loadbay of the Quartermaster. They are supplied with four Quick Release Tie-Down Rings, which slot into the pre-defined locations along the rail.

## Roof Loading



**WARNING:** Be aware of load height on the vehicle (including any roof racks) when using tunnels or locations with height restrictions such as car parks with entrance height restrictions.



**WARNING:** If loading large items or heavy items, take care and do this with the help of multiple people. It is also advised that the appropriate loading equipment is used where possible to avoid injury or death.



**CAUTION:** Only INEOS original Roof Rack / Roof Bars are allowed to fix on drain gutter. Payload must be

# VEHICLE OPERATION

distributed equally and payload centre of gravity should be as low as possible.



**CAUTION:** Maximum roof load capacity (with Roof Rack accessory) is 420 kg (925 lbs) static and 150 kg (330 lbs) while driving (dynamic).



**CAUTION:** Maximum roof load capacity (with 6-Foot Roof Rack accessory and the Quartermaster Roof Rack accessory) is 375 kg (826 lbs) static and 120 kg (264 lbs) while driving (dynamic).

When loading the roof of the vehicle it is important to obey any applicable laws or regulations related to driving with a roof load.

INEOS recommends the heaviest items are loaded into the rear of the vehicle and the lighter items are loaded onto the roof.

Always inspect the roof load and any roof racks before use. It is important to follow the manufacturers instructions for maintenance to ensure a safe and secure roof load.

When loading the roof, think about the positioning of items before securing in place. The shape, weight and size of the items loaded onto the roof can change the handling characteristics of the vehicle. Plan in advance how everything will be tied down and positioned. Long items such as canoes or surf boards may have some over hang. Remember that this can not only alter the height of the vehicle, but the length too.

## Access Ladder (OPTIONAL)



**WARNING:** Maximum load capacity on the Access Ladder is 150 kg (330 lbs).



**WARNING:** The Access Ladder can only be used when the 30/70 split doors are completely closed. Use of the ladder with the 30/70 split doors open, can result in injury or damage to the vehicle.

The Access Ladder can be found at the rear of the Station Wagon and Utility Wagon vehicles

## Driving with a Roof Load



**WARNING:** Avoid sudden steering movements as this can make the load unstable, or even cause the vehicle to over turn causing serious injury or death.



**WARNING:** Avoid traversing side slopes which can tip the vehicle.



**WARNING:** Make sure to adjust the pressure of the vehicle tyres to drive with the added weight of the roof load.

If travelling for a long duration, then it is essential to take regular stops or comfort breaks to walk around the vehicle, checking the

# VEHICLE OPERATION

roof load for security. Any securing equipment such as ties or straps should be checked to make sure nothing has moved or become unstable. Failure to do so could result in injury or death if items were to move or fall from the vehicle.

When operating the vehicle with a roof load, the weight of the vehicle is increased. This means it will take longer to slow down or stop when braking. It is advised to drive at a slower speed with the extra weight carried. Be vigilant and sensible.

## FUELLING



**WARNING:** Before fuelling, switch off ignition and never allow sparks or flames near the fuelling tank filler valve. Follow the operating and safety instructions of the filling station when fuelling.



**WARNING:** Do not allow naked flames near fuel.



**WARNING:** Do not smoke near fuel.



**WARNING:** Fuel and fuel vapour is explosive. Do not create sparks if you are near fuel or if you can smell fuel in and around the vehicle. If you can smell fuel in your vehicle, have this investigated immediately by an INEOS approved partner or notify your emergency services.



**WARNING:** The fuel system may be under pressure. If you hear a hissing sound near the fuel filler inlet, do not refuel until the sound stops. Otherwise, fuel may leak out, which could cause serious personal injury.



**WARNING:** Do not overfill the fuel tank. The pressure in an overfilled tank may cause leakage and lead to a fuel leak and risk of fire.



*NOTE:* Do not fill the fuel tank in the event of parking on a slope, such as, a steep driveway or on a hill. The fuel can escape through the overflow and be spilt onto the driveway or road.

Fuel pumps have an automatic cut off when the tank is full. Do not continue fuelling past a full tank as this will lead to spillage from the overflow. It is critical that you follow the health and safety rules of the filling station. It is recommended not to do the following, in a filling station:

- > Smoke.
- > Use mobile phone.
- > Create a spark.
- > Use a naked flame.



*NOTE:* It is recommended, that you wear protective gloves when filling with fuel at a fuel station.

# VEHICLE OPERATION

## Fuel Level and Remaining Range Warnings

The remaining fuel range and the current fuel level, can be seen by looking at the infotainment screen.

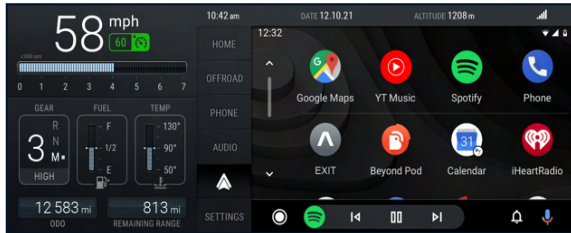

There are three stages of fuel level warning:

1. The fuel level gauge and the remaining range will change colour from white to amber, when the remaining fuel is between 74 miles (120km) and 43 miles (70 km). This is a

warning that the fuel is getting low, and that the vehicle will need to be refuelled soon.

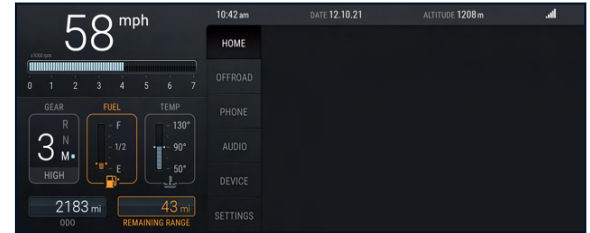

2. Secondly, the remaining range will be replaced with a message, notifying the driver that they should refuel soon.

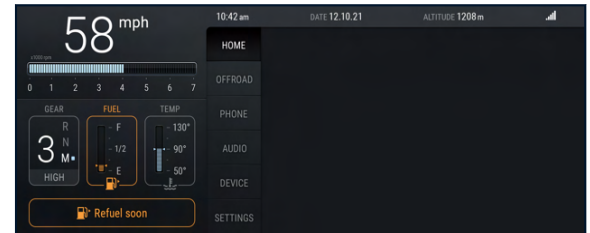

3. The third warning changes the fuel level gauge and the remaining range from amber to red when the remaining range is less than 43 miles (70 km). This is a warning that the vehicle is using reserve fuel, and must be refuelled as soon as possible.



# VEHICLE OPERATION



## Opening Fuel Flap

The fuel flap is located at the rear, right side of the vehicle.

The vehicle must be unlocked to open the fuel flap. To open the fuel flap, push the rear edge of the fuel flap inwards and release. The fuel flap will pop open.

To close the fuel flap, push the rear edge, until the fuel flap is securely closed.

## Opening Fuel Cap

Turn the cap slowly anti-clockwise to open. Once the cap is loose, hook it onto the inside of the fuel flap.

## AdBlue (EU6 Diesel Engine Only)



**WARNING:** Do not fill the AdBlue with the engine running.



**WARNING:** AdBlue is non-toxic but can cause irritation to the skin and eyes. Wash from the skin and/or eyes immediately with water, immediately seek medical attention.



**CAUTION:** Immediately wash any AdBlue from the body work of the vehicle. AdBlue can damage vehicle paint if left on vehicle body.



**CAUTION:** Do not put AdBlue into the diesel tank, as this will cause damage to the fuel tank, pump, and injection system. If there is AdBlue inside the diesel tank, do not turn on the ignition or start the engine and call your nearest INEOS approved partner.



**CAUTION:** Do not overfill the AdBlue reservoir, failure to do this may result in damage to the vehicle components. If the AdBlue reservoir is overfilled, consult with your INEOS approved partner for support.

AdBlue is a colourless, non-toxic mixture of urea and de-ionised water. Tiny amounts of AdBlue are injected into the flow of exhaust gases. At high temperatures AdBlue turns to ammonia and carbon dioxide.

Harmful nitrogen oxide in the exhaust reacts with the ammonia inside the Selective Catalytic Reduction (SCR) catalyst, and is transformed into harmless nitrogen and water.

# VEHICLE OPERATION

## AdBlue Levels

**i** *NOTE: INEOS recommends that the engine is switched off, when filling up the AdBlue .*

The AdBlue tank capacity is approximately 17 litres (4.4 gallons). To check the level of AdBlue , navigate to the settings on the infotainment screen. Select vehicle Functions, vehicle information and then AdBlue . The AdBlue level will be shown as a percentage and the quantity required to top up until full.

If the level of AdBlue falls below 25%, then the colour of the percentage will change to amber, indicating the AdBlue will need topping up soon. If the tank level falls to 10% or below, then the percentage level will change to red to indicate the AdBlue tank should be filled as soon as possible.

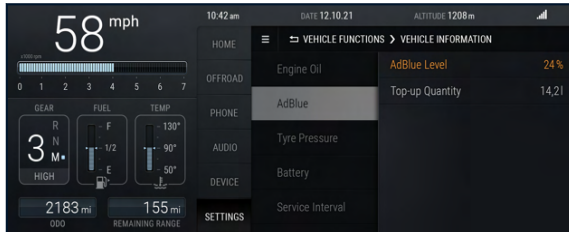

An AdBlue Reserve warning will be activated, when the remaining distance reaches 1,490 miles (2,400 km).

AdBlue reserve

AdBlue level low- Please refill AdBlue

An AdBlue warning will be visible when the remaining distance is 248 miles (400 km) or less. The remaining distance will be visible on the infotainment screen between 248 miles (400 km) and 0 miles (0 km).

AdBlue - No restart in 248 miles (400 km)

No restart in 248 miles (400 km)- Please refill AdBlue

When the **AdBlue** distance remaining reaches 0 miles (0 km), the warning message below will be visible:

No start- fill AdBlue

AdBlue empty- Please refill AdBlue or engine will not start

**i** *NOTE: If the level of AdBlue in the tank is completely depleted, then the engine will not start. If this happens, refill the AdBlue immediately. Once refilled, make sure the ignition and engine are switched off so when you restart the vehicle, the warning will be extinguished. It is advised to wait a short period of time before restarting the vehicle.*

# VEHICLE OPERATION

## AdBlue Filler Location

AdBlue is an exhaust fluid, not a fuel additive. It is stored in a separate reservoir and is topped up through the AdBlue filler cap, located next to the fuel filler cap.



*NOTE: Only use a car nozzle when filling the vehicle with adblue.*

## PARTICULATE FILTERS

### Diesel Particulate Filter (DPF)

The DPF forms part of the emissions reduction systems fitted to your vehicle. The DPF is designed to filter harmful diesel gases and particulates, such as, soot from exiting the vehicle into the atmosphere.

### Regeneration



**WARNING: Do not leave your vehicle parked or idling over dried grass or leaves and any other combustible materials. The DPF regeneration process causes the exhaust to be extremely hot, which will radiate heat for some time after the regeneration process has been completed. Allow the vehicle to cool down where there**

**are no combustible materials and where there is good air ventilation.**



**CAUTION: Make sure there is enough fuel in the vehicle to complete the full regeneration process. Failure to do this will result in the vehicle running out of fuel, which can cause potential damage to the vehicle.**



Unlike a normal filter, which requires periodic replacement, the DPF has been designed to regenerate, or clean itself to maintain operating efficiency. The filter is cleaned periodically by burning off the soot particles within the DPF at high temperatures.

If the vehicle is being driven short distances or even long distances with frequent acceleration and deceleration or stopping and starting then this can lead to a build up of soot inside the DPF. To prolong the life of the DPF and to assist with the regeneration process:

- > Preferably drive on a motorway or dual carriageway where the vehicle can be driven at a constant speed with minimal risk, while observing the road conditions and speed limits.
- > Avoid prolonged idling and stop/start driving.
- > Do not switch off the ignition part way through the journey.
- > The journey should be a minimum of 20 minutes to allow the engine and DPF to reach normal operating temperature.
- > Where appropriate and safe, use a lower gear than normal to maintain higher engine speed above 2000 rpm, also keeping the temperature high in the DPF.

## VEHICLE OPERATION

 **NOTE:** Fuel consumption may be higher during this period. The emission smoke and the smell of burning during this process is normal, the DPF is regenerating and burning the contents inside.

 **NOTE:** Upon completion of the journey, there might be a clicking metallic sound or hot metallic odour from the vehicle. This is normal due to the high temperatures sustained through the regeneration process. If the regeneration process is not possible, or there is an issue with the DPF, the engine light  will illuminate.

 **CAUTION:** For any suspected issues with the DPF system, contact your nearest INEOS approved partner for advice. Do not ignore or drive long distances with a fault, until the DPF system has been serviced or replaced.

### Gasoline Particulate Filter (GPF)

The GPF system, is designed to reduce harmful gases and particulate emissions emitting from the vehicle, through the exhaust system. Particulates over time will be burnt away at high temperatures, this is known as regeneration and happens automatically when driving the vehicle.

### Regeneration

Unlike a normal filter, which requires periodic replacement or regeneration, the GPF has been designed to operate at high temperatures to keep the GPF system from becoming blocked. The GPF will gather and burn harmful particulates while you are driving to

avoid any harmful particulates being emitted by the exhaust system and entering the atmosphere.

If the vehicle is being driven on regular short distance trips, it is recommended that you take the vehicle for an occasional drive on a motorway or dual carriageway, observing the road conditions and speed limits, allowing the engine and GPF to heat up to a high temperature to burn any particulates gathered.

 **NOTE:** Avoid prolonged idling and stop/start driving, as this can lead to a build up of particulates inside the GPF.

 **WARNING:** For any suspected issues with the GPF system, contact your nearest INEOS approved partner for advice. Do not ignore or drive long distances, until the GPF system has been serviced or replaced.

### Catalytic Converter

The catalytic converter reduces harmful substances emitted into the atmosphere with exhaust gases.

## DRIVER SUPPORT AND FEATURES

---

OFF-ROAD DRIVING .....	94
CRUISE CONTROL .....	97
EMERGENCY STOP SIGNAL (ESS) .....	100
ELECTRONIC STABILITY CONTROL (ESC) .....	100
ANTI-LOCK BRAKE SYSTEM (ABS) .....	103
DOWNHILL ASSIST .....	103
UPHILL ASSIST .....	104
PARKING AID SYSTEMS .....	104
REAR-VIEW CAMERA (OPTIONAL) .....	108
SOS EMERGENCY CALL .....	109
ROADSIDE EMERGENCIES .....	109
VEHICLE RECOVERY .....	115
TOWING A TRAILER .....	120

# DRIVER SUPPORT AND FEATURES

## OFF-ROAD DRIVING

The Grenadier is a capable off-road vehicle, but driving off-road can be dangerous. If possible, seek specialist advice and training.

 **WARNING:** Do not take any unnecessary risks and be prepared for emergencies at all times.

 **WARNING:** Be sure the driver has the relevant knowledge of off-road driving techniques in order to minimise any risks to you, the driver, passengers and the vehicle.

 **WARNING:** Always use your seat belt, when driving in all off-road driving modes, to ensure personal safety.

 **CAUTION:** Make sure the vehicle has enough fuel before off-road driving. If the fuel level is low then uneven ground and steep inclines could cause damage to the engine.

 **CAUTION:** Do not drive off-road with roof loaded. It is recommended, any luggage on the roof is removed before off-road driving. Especially before traversing side slopes.

The off-roading and wading control buttons are located within the roof console.



*NOTE: Off-road Mode and Wading Mode should not be used on public roads.*

## Off-road Mode



**WARNING:** When the ESC OFF tell-tale is illuminated, caution should be exercised due to reduced stability functionality.

Off-road Mode, can be activated by pressing the Off-road Mode button , located on the roof console.

To activate Off-road Mode, the vehicle must be stationary with the engine running and the handbrake on. The button has to be pressed for approximately one second, upon releasing the button, there is a fifteen second window to confirm activation of the Off-road Mode. To confirm, press the Off-road Mode button again and there will be an acoustic signal to confirm the activation has been completed. Once the activation has been confirmed there will be two tell-tale lamps

illuminated, one being the Off-road Mode lamp  and the other

will be the ESC Off lamp . Furthermore, the infotainment unit will display a message, confirming the Off-road Mode activation and the button itself will illuminate a small LED.

To turn off the Off-road Mode, hold the Off-road Mode button  for at least one second and then release it. The button LED and the

# DRIVER SUPPORT AND FEATURES

two tell-tale lamps will switch off, this will indicate that the Off-road Mode has been deactivated.

When Off-road Mode is switched on, the Electronic Stability Control system becomes ESC Off-road. With ESC off-road mode engaged, the ESC functionality is reduced. Caution should be exercised.



*NOTE: Off-road Mode will automatically deactivate, if the vehicle travels faster than 44 mph (70 km/h) or if the engine is turned off, for longer than thirty seconds.*

CHANGES WHEN ACTIVATING OFF-ROAD MODE		
DEACTIVATED	ACTIVATED	CHANGED
Emergency Signal System (ESS)	Thermal mode	Electronic stability control (ESC)
Park Distance Control (PDC) Automatic		
Acoustic driver door status warning		
Roadside-to-vehicle communications (RVC)		
Acoustic seat belt reminder		

## Wading Mode



**WARNING:** Keep the doors closed at all times when wading. Failure to do this can lead to interior flooding of the vehicle. This will damage the vehicle and risk injury to the occupants or even death.



**CAUTION:** The maximum wading depth is 800 mm (31.5 in). Wading in water deeper than 800 mm (31.5 in) may damage the vehicle.



**CAUTION:** Never exceed 3 mph (5 km/h) during wading. If the maximum wading speed is not adhered to, then a wave might be generated that could enter the air intakes, causing irreversible engine damage (hydro lock).



**CAUTION:** Maximum continuous wading duration is 20 minutes. You should not wade continuously for more than 20 minutes. Wading for longer than 20 minutes may damage the vehicle and even result in the vehicle needing recovery.





**CAUTION:** Let the vehicle idle for a minimum of 20 minutes or drive the vehicle for 20 minutes straight after wading. Failure to do this can damage the starter motor.



**CAUTION:** Do not switch off the engine during wading, this may cause major damage to the powertrain.

## DRIVER SUPPORT AND FEATURES

 **NOTE:** The approach and departure angle is 16° (30%) for wading only.

 **NOTE:** In order to activate Wading Mode, the transfer case should be in 'LOW' and the centre differential lock should be engaged.

Wading Mode can be activated by pressing the Wading Mode button



located on the roof console. Press the button for approximately one second, upon releasing the button, there is a fifteen second window to confirm activation. To confirm, press and hold the Wading Mode button until an acoustic signal is heard. Once the activation

has been confirmed the Off-road Mode lamp  and the ESC OFF



lamp  will be illuminated. The infotainment screen will display a message to confirm that the Wading Mode has been activated and the LED on the button will be illuminated.

To turn off the Wading Mode, press and hold the Wading Mode



button for at least one second. The button LED and two tell-tale lamps will switch off, this will indicate that the Wading Mode has been deactivated.

Alternatively, Wading Mode will automatically deactivate in the following circumstances:

-  Off-road Mode has been deactivated
-  Centre differential has been disengaged

 Transfer case has been changed from 'LOW' to 'HIGH'.

CHANGES WHEN ACTIVATING WADING MODE		
DEACTIVATED	ACTIVATED	CHANGED
DPF / GPF regeneration	Air circulation mode	Electronic stability control (ESC)
Side engine fans	Speed limiter 18 mph (30 km/h)	
Seat heating (if applicable)		
PDC Automatic		
Acoustic driver door status warning		
RVC automatic (still configurable by driver)		
Acoustic seat belt reminder		
Selective Catalytic Reduction (SCR) heating		
Particulate Matter (PM) / Nitrogen Oxides (NOX) Sensors		



# DRIVER SUPPORT AND FEATURES

---

## Off-Road and Wading Mode Malfunction

If there is a malfunction, there will be no acoustic signal or indicator, when trying to switch modes.

In the case of a malfunction, It is recommended that the vehicle is not taken off-road as the vehicle will not have full capability to handle off-road surfaces and uneven ground. Under no circumstance should the vehicle be taken wading if there is a malfunction as this can damage the vehicle.

## Raised Air Intake (OPTIONAL)

Raising the position of the engine air intake ensures the engine is fed with cleaner and cooler air in dusty environments.



*NOTE: The Raised Air Intake does not improve wading performance or maximum wading depth.*

## Raised Air intake Cyclone Pre-Cleaner (ACCESSORY)



**CAUTION:** Only use the Raised Air intake Cyclone Pre-Cleaner when driving off road.

This attachment uses cyclone technology to spin the air at high speed before it enters the raised air intake air duct. This provides a centrifugal effect to any dust and dirt, preventing contaminants from entering the engine air intake. Recommended for very dusty and dirty environments.

## CRUISE CONTROL



**WARNING:** Driver assistance systems are not designed to allow the driver a pause in concentration or to replace the drivers attention under any circumstance. The driver accepts full responsibility when driving the vehicle.



**WARNING:** Cruise Control is a driving aid to give comfort to the driver when driving for prolonged periods of time at a particular speed. It is essential the driver keeps concentration, only using Cruise Control when road and traffic conditions are suitable. Failure to do so, may cause an accident or collision resulting in death or serious injury.



**WARNING:** Cruise Control is developed as an aid only and can't take into account the road or weather conditions as they change. You as a driver are responsible for the vehicle speed set, applying the brakes smoothly and in good time, controlling the distance between you and any vehicle(s) nearby.



**WARNING:** Cruise Control is used to set a particular speed by the driver only, the driver is always responsible for keeping the vehicle under control inside the lane being used. Failure to keep the vehicle in the lane due to a lapse in concentration, can cause an accident or collision resulting in death or serious injury.

## DRIVER SUPPORT AND FEATURES

The Cruise Control system should not be used when:

- road and traffic conditions do not allow you to maintain a constant speed, e.g. in heavy traffic or on winding roads.
- driving on rough terrain or surfaces that might be slippery. For example, ice, gravel, sand or water.
- driving in any conditions likely to cause the vehicle to skid, slide or lose traction when braking or accelerating.
- visibility is poor in severe weather conditions, such as heavy rain, fog, or snow.

### Activating Cruise Control

The Cruise Control is activated using the buttons on the steering wheel.

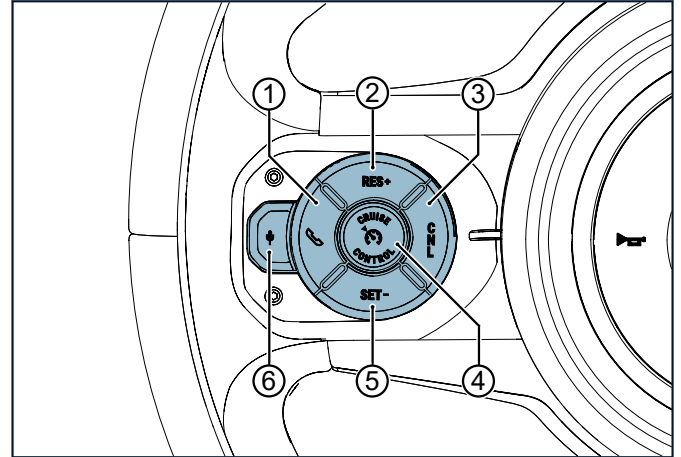

Press the Cruise Control button  (4), to activate the Cruise Control feature, in a standby state. This will be indicated on the

## DRIVER SUPPORT AND FEATURES

infotainment screen by the grey Cruise Control symbol next to the speed value.



### Adjusting Speed



*NOTE: Cruise Control will only operate at speeds above 19 mph (30 km/h).*

Press the 'Set -' button (5), to set the Cruise Control to the current speed. Once active, the symbol will turn green and show the current set Cruise Control speed.



The displayed speed will be in green if it matches the set speed chosen by the driver. If the current speed differs from the set speed, it will be displayed in grey instead of green. To adjust the set speed, you can use the 'RES +' button (2) to increase it or the 'SET -' button (5) to decrease it. A brief press of either button will adjust the speed

incrementally, while holding down the button will result in larger adjustments.



*NOTE: Cruise Control will automatically disengage when the brake pedal is pressed or when the vehicle speed falls below 19 mph (30 km/h).*

### Resume Set Speed



**WARNING: Set speed should only be resumed if it is safe to do so and the driver is aware of the set speed and intends to return to it. The driver must be aware of the traffic and weather conditions before resuming the last set speed.**

If at any point the driver presses the "CNL" button (3) the Cruise Control feature will go into standby mode. The same is true if the brake pedal is pressed or the Electronic Stability Control (ESC) activates. The last set speed will be saved and the Cruise Control symbol will be greyed out, including the speed number.

Pressing the "RES +" button (2) will reactivate the Cruise Control to the speed last set. If the "SET -" button (5) is pressed, then the saved speed is overwritten by the current speed.

### Deactivating Cruise Control

The "CNL" button (3) puts the Cruise Control back into standby. The same is true if the brake pedal is pressed or the Electronic Stability Control (ESC) activates. Once the Cruise Control is in standby mode,

# DRIVER SUPPORT AND FEATURES

press the Cruise Control button  (4) once to deactivate Cruise Control.

## EMERGENCY STOP SIGNAL (ESS)

If you brake heavily, the ESS function is triggered. The brake lamps will flash automatically when braking heavily and the hazard lamps will automatically activate once the vehicle has come to a stop.

## ELECTRONIC STABILITY CONTROL (ESC)

 **WARNING: The electronic stability control system is a driving aid, the driver must keep concentration and pay attention to the traffic around them. The driver must be ready to react to any change in the surrounding traffic, weather conditions, surface changes or obstacles in the way of vehicle travel.**

 **WARNING: Do not deactivate the electronic stability control when driving with the roof loaded. The centre of**

**gravity is higher when driving with a roof load creating a much higher risk of tipping or an accident. This is particularly important in the event of sudden reactions such as avoiding obstacles in the road.**



**WARNING: When the rear and/or front differentials are locked, there is no stability support available to aid the driver. Drive the vehicle with extreme caution!**

When ESC is actively supporting the driver, the ESC tell-tale lamp







will blink.



ESC aids the driver by supporting the stability of the vehicle using engine and braking interventions. Switching off the ESC reduces the stability control functions available to the driver.

ESC may support the driver differently depending on the vehicle state. See in the following tables, how ESC aids the driver depending on the vehicle state and whether or not the ESC OFF button is pressed.

## DRIVER SUPPORT AND FEATURES



VEHICLE STATE	ESC OFF (Button Not Pressed)	ESC OFF (Button Pressed)
High / Low Gear (Centre Differential Not Locked)	Default Mode	<b>ESC OFF Mode (Reduced Stability)</b> > Display Text: ESC OFF > Tell-Tale:  OFF
High / Low Gear (Centre Differential Locked)	<b>ESC in Off-road Mode</b> > Display Text: ESC Off-road > Tell-Tale:  OFF	<b>ESC OFF Mode (Reduced Stability)</b> > Display Text: ESC OFF > Tell-Tale:  OFF
Off-road / Wading Active	<b>ESC in Off-road Mode</b> > Display Text: ESC Off-road > Tell-Tale:  OFF	<b>ESC OFF Mode (Reduced Stability)</b> > Display Text: ESC OFF > Tell-Tale:  OFF

# DRIVER SUPPORT AND FEATURES



VEHICLE STATE	ESC OFF (Button Not Pressed)	ESC OFF (Button Pressed)
Rear / Front Differential Locked	<p><b>ESC and ABS OFF (No stability support available)</b></p> <p>&gt; Display Text: ESC and ABS OFF</p> <p>&gt; Tell-Tale:  </p>	ESC OFF not available

- > Trailer Stability Assist function only active in Default Mode.
- > Downhill Assist is not available in ESC Off Mode.
- > Downhill Assist is not available when the rear and/or front differentials are locked.
- > Uphill Assist is not available when the rear and/or front differentials are locked.



## ESC OFF Mode

-  **WARNING: When ESC is deactivated, the vehicles driving stability will be reduced when accelerating or cornering. Caution must be exercised!**
-  **WARNING: If the ESC symbol  stays illuminated, the ESC system has detected a fault. No stability support available when there is a fault. Consult immediately with your nearest INEOS approved partner.**

It is not possible to deactivate ESC, while ESC is actively supporting the driver.



To deactivate ESC, hold down the ESC OFF button  located in the roof console. Hold the button until the tell-tale lamp  is illuminated and the infotainment screen displays ESC OFF.

When the vehicle is being driven in ESC OFF mode, the maximum speed before automatically reverting back to off-road mode or default mode is 48 mph (78 km/h).

To re-activate ESC, press and hold the ESC button  until the ESC OFF tell-tale lamp  is extinguished.

# DRIVER SUPPORT AND FEATURES

## ANTI-LOCK BRAKE SYSTEM (ABS)

 **WARNING:** If the ABS lamp  is illuminated and the rear and/or front differentials are unlocked, then this means there is a fault. Consult immediately with an INEOS approved partner.

The anti-lock braking system (ABS) is designed to aid the driver during braking to improve the vehicle stability. ABS will activate to avoid the wheels locking up if the car loses traction.

## DOWNHILL ASSIST

 **WARNING:** Downhill Assist is a driving aid. The driver must always be in control of the vehicle.

 **WARNING:** The driver must be ready to react to any change in the surrounding traffic, weather conditions, surface changes or obstacles in the way of vehicle travel.

Downhill Assist aids the driver by controlling the vehicle speed when going down hill. The driver is not required to use the brake pedal when using this feature.

Downhill Assist controls the speed of the vehicle to keep the vehicle stable while aiding the driver. The system will apply the brakes to individual wheels, keeping the vehicle stable moving down hill.

## Activating Downhill Assist

Downhill Assist can only be activated, if the rear and/or front differentials are not engaged. In addition, the vehicle must not be travelling forwards above 15 mph (25 km/h), or reversing above 6 mph (10 km/h).

Press the Downhill Assist button  located in the overhead control panel, to activate Downhill Assist.

Once activated, the infotainment screen will display the Downhill Assist symbol in green.

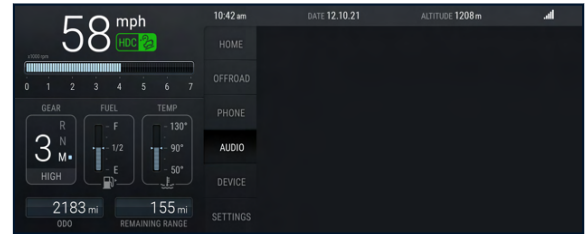

The same symbol will blink when Downhill Assist is in control.



**NOTE:** Downhill Assist is not available, when ESC OFF has been pressed or when the rear and/or front differentials are engaged.

# DRIVER SUPPORT AND FEATURES

## Adjusting Speed

 **NOTE:** Downhill Assist will only operate at speeds less than 15 mph (25 km/h) or reversing at speeds below 6 mph (10 km/h)

The Downhill Assist speed can be increased or decreased by pressing the “RES +” button (2) or the “SET -” button (5), located on the steering wheel.

## Deactivating Downhill Assist

Press the Downhill Assist button  once to deactivate Downhill Assist. Downhill Assist will automatically disengage if the driver accelerates above 15 mph (25 km/h), or 6 mph (10 km/h) in reverse.

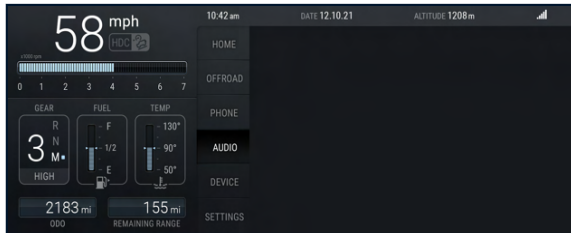

 **NOTE:** If ESC OFF is pressed, then downhill Assist is automatically deactivated.

 **NOTE:** When activating the rear and/or front differential lock, Downhill Assist will automatically deactivate.

## UPHILL ASSIST

 **WARNING:** If the rear and/or front differential is locked, then Uphill Assist will not be available.

Uphill Assist is a driving aid designed to hold the vehicle for a short time only in the event of a hill start. It is the drivers responsibility to ensure that the vehicle does not roll back even when the feature is active.

The appropriate gear must be selected depending on the direction of travel, in order for the feature to become active. Uphill assist is not available when neutral is selected.

If the vehicle is in gear, and there is a gradient of 3% or more detected, then the vehicle is held stationary for two seconds after the brake pedal is released.

## PARKING AID SYSTEMS

 **WARNING:** The parking aid systems are for aid only. It is the driver's responsibility to be aware of their surroundings when parking or reversing.



# DRIVER SUPPORT AND FEATURES

**i** *NOTE: When the tow bar socket is used for tow bar mounted items, such as an accessory bike rack or trailer, the rear parking sensors and Active Park Assist systems will be deactivated.*

**i** *NOTE: The Bull/Roo Bar accessory and/or third-party Bull/Roo Bars may interfere with the front parking sensors. Consult your nearest INEOS approved partner when installing any Bull/Roo Bar accessory.*

## Park Distance Control

**!** **CAUTION:** Drivers must always be vigilant in detecting obstacles and estimating the vehicle's distance from them. The system may not detect some overhanging objects, barriers, thin obstructions, or painted surfaces that could potentially damage the vehicle. Remain aware of your surroundings when using parking aid systems.

**!** **CAUTION:** Do not clean the sensors with abrasive or sharp objects. This could result in damage to the sensors.

**i** *NOTE: For reliable operation, the sensors in the front and the rear bumpers should be kept free from ice, frost and dirt. If a high pressure spray is used to clean the vehicle, the sensors should only be sprayed briefly and from a distance greater than 20 cm.*

The Park Distance Control (PDC) system uses four sensors at the rear of the vehicle and optionally, four more sensors at the front of the vehicle.

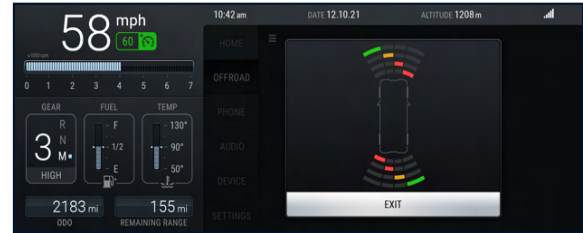

Park Assist Rear alerts the driver with audible and visual warnings on the infotainment screen at low speeds when objects or vehicles are detected behind the vehicle. If available, Park Assist Front offers similar warnings for objects or vehicles in front of the vehicle.

## Parking Sensor Activation

The PDC system, is automatically activated when the reverse gear is engaged.

When the vehicle is in reverse gear **R**, the Park Assist Rear will automatically activate only if the current driving mode is set to 'Normal Mode'. Automatic activation will not occur when in 'Off-Road Mode' or 'Wading Mode'.

**i** *NOTE: If the handbrake is applied while reverse gear is selected, the reverse camera will still work, but a*

# DRIVER SUPPORT AND FEATURES

message will appear on the infotainment screen. The Park Distance Control (PDC) rear will be deactivated, and the switch on the center control unit panel will be inactive.

## Parking Sensor Deactivation

The system can be deactivated, manually by pressing the  button (8), located in the bottom right corner of the centre console, or automatically when the park gear **P** is engaged or the handbrake is applied. The PDC will automatically deactivate, if the vehicle speed surpasses a defined threshold of 10 mph (15 km/h), or a continuously covered distance of 50 m (164 ft) forward.

If the vehicle is in 'Off-road Mode' or 'Wading Mode', the PDC will automatically deactivate. Park Assist Front (if applicable) can be manually switched off in the settings menu, with a confirmation displayed on the infotainment screen.

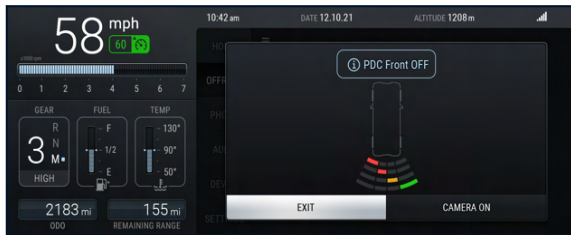

Park Assist Rear, will automatically switch off if there is a trailer attached. This will be visible on the infotainment screen.

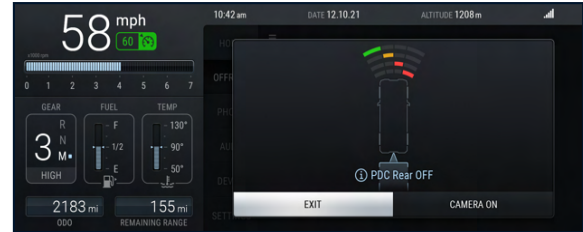

## Parking Sensor Operation



**CAUTION:** In heavy rain or similar adverse conditions, the PDC sensors may not always be able to accurately measure distance to close objects. A fully laden vehicle or irregular obstacles may also cause inaccurate measurements. Take extra care in these circumstances.

If an obstacle is detected at the front or rear of the vehicle, a series of warning tones will be heard. The frequency of the warning tones increase as the vehicle approaches the obstacle.

The beep becomes a continuous tone when an obstacle is detected at or within approximately 0.4 m (1.3 ft) of the vehicle.

## DRIVER SUPPORT AND FEATURES

**i** *NOTE: If an ultrasonic frequency using the same frequency band as the sensors is detected, the PDC system can give spurious warning tones.*

**i** *NOTE: The PDC system uses inner and outer sensors. When manoeuvring forward into a garage, the front outer sensors will cease detection if they detect a stationary or receding object for three seconds or more. This allows detection directly in front or behind the vehicle in this type of manoeuvre.*

**i** *NOTE: If there is a fault, then a warning message will be displayed on the infotainment screen.*

### Parking Distance Control Malfunction

**i** *NOTE: If there is a fault, then a warning message will be displayed on the infotainment screen.*

If there is a fault with the Park Assist Front (if applicable) or the Park Assist Rear, then there will be an error message displayed on the infotainment screen.

Park Assist Front (if applicable):



Park Assist Rear:

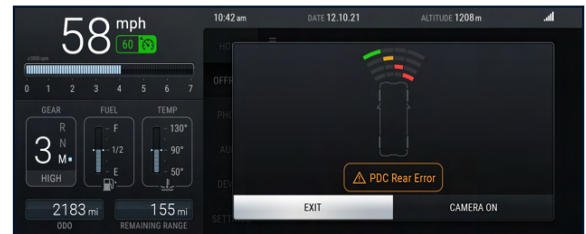

# DRIVER SUPPORT AND FEATURES

## REAR-VIEW CAMERA (OPTIONAL)

The wide-angle Rear-View Camera enhances maneuverability in tight spaces, both on and off-road, by providing improved visibility of obstructions or low objects when reversing.

### Rear-View Camera Activation

When the vehicle is in 'Off-road Mode' or 'Wading Mode' the reverse camera can be activated manually inside the off-road settings.

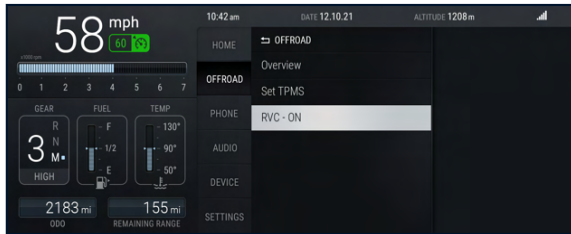

When the Rear-View Camera is activated, the camera screen will be displayed on the infotainment screen, along side the PDC display.

### Rear-View Camera Deactivation

The Rear-View Camera can be switched off by pressing 'CAMERA OFF' on the infotainment screen.



Press 'CAMERA ON' to switch the Rear-View Camera back on again.

If the Rear-View Camera is unavailable, the camera screen will be replaced with a warning message.

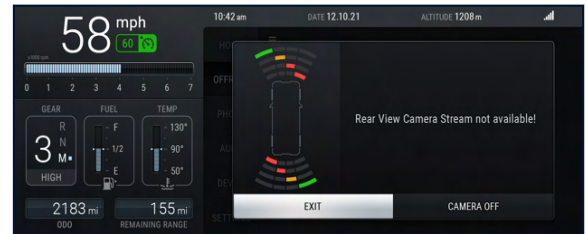

# DRIVER SUPPORT AND FEATURES

The Rear-View Camera overlay window can be closed at any time by pressing 'EXIT'.

## SOS EMERGENCY CALL



**WARNING:** The SOS Emergency Call feature, also known as the eCall system, is not a rescue service, and INEOS cannot guarantee a response. It's essential to adequately prepare for journeys, especially off-road or adventurous ones, and not rely solely on the eCall system to notify emergency services.

The eCall system, offers users an emergency call system utilising GPS satellite technology to pinpoint accident locations accurately. It can activate manually or automatically, indicated by a green LED on the SOS button once a voice connection is established. During ignition, a red LED indicates self-test, turning green within a minute if no errors occur. Contact an INEOS Partner if the red LED remains on continuously for support.

## Manual Operation

To Manually operate the emergency call system:

1. Open the eCall switch cover, located in the roof console.
2. Press and hold the button, until the green LED flashes.
3. After eight seconds, the vehicle will dial a emergency call operative to assist.

Manually activate the eCall system in situations that require emergency assistance, such as non-severe accidents or incidents near your vehicle that necessitate emergency services.



*NOTE: The emergency call function should only be utilised in situations requiring immediate assistance. It should not be used for non-emergency scenarios like breakdowns.*

## Automatic Operation

The eCall system is directly connected to the occupant restraint control system (ORC). When there is an incident or road collision with airbag deployment, the eCall system will automatically contact an emergency operative to advise. The operating Center will also receive a text message with information, such as, current location.



*NOTE: The eCall system is integrated with the occupant restraint control system (ORC). In the event of a collision triggering airbag deployment, the eCall system will automatically notify emergency services. Additionally, the operating centre will receive a text message including the vehicle's current location.*

## Malfunction Warning

If the eCall system experiences a component failure, the eCall button LED will remain red. In such instances, it's crucial to seek assistance from an INEOS partner to address the system fault

## ROADSIDE EMERGENCIES

## DRIVER SUPPORT AND FEATURES

### FIRST AID KIT

The Station / Utility Wagon may come with a First Aid Kit (2). The kit (if applicable) is located in the rear door of the vehicle.

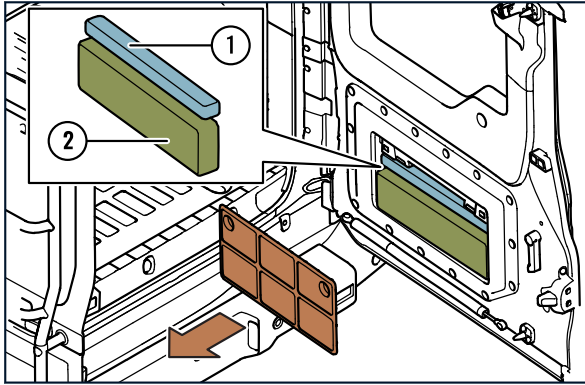

For the Quartermaster, the First Aid Kit (if applicable) is located behind the Rear Bench Seat.

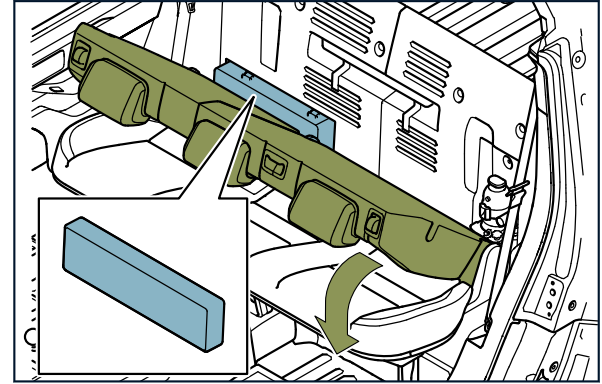

### WARNING TRIANGLE (OPTIONAL)

The Station / Utility Wagon may come with a Warning Triangle (if applicable), the Warning Triangle is located in the rear door of the vehicle (1). This device alerts other drivers to your presence on the roadside, giving them time to adjust their speed and position safely.

## DRIVER SUPPORT AND FEATURES

For the Quartermaster, a Warning Triangle may come with the vehicle. The Warning Triangle (if applicable), is located behind the Rear Bench Seat.

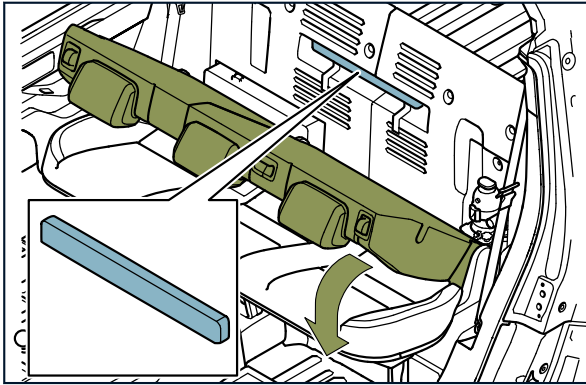

### FIRE EXTINGUISHER (OPTIONAL)

The fire extinguisher, included in the 'Roadside Emergency Kit Plus' option, if applicable, is typically located in front of the front passenger seat. This device is for emergency use, and it's essential to follow the manufacturer's instruction label on the extinguisher.

### WARNING VEST

The vehicle may come with a hi-vis warning vest. If applicable, the vest is located in the rear door of the Station / Utility Wagons and behind the rear bench seat for the Quartermaster. Always keep the hi-vis warning vest with the vehicle and wear in the case of an emergency or breakdown.

### VEHICLE TOOL KIT

The vehicle contains a tool kit for emergencies like changing a wheel roadside. Located under the driver's seat, access the kit by opening the driver-side door, undoing the retaining strap, and sliding it out when safe.

### BOTTLE JACK



**WARNING:** Make sure heavy luggage and/or passengers are out of the vehicle, and any connected trailer is unhitched, before raising the vehicle with the Bottle Jack.



**WARNING:** Make sure the vehicle is on stable and level ground, before lifting the vehicle using the Bottle Jack.



**WARNING:** No persons should be under the vehicle for any reason when the vehicle is lifted on the Bottle Jack.

## DRIVER SUPPORT AND FEATURES



**CAUTION:** The top threaded extension of the Bottle Jack **MUST** be unscrewed to its upper stop position prior to use.

The Station/Utility Wagon houses a Bottle Jack for emergencies like changing a wheel roadside. It's situated in the rear loading area behind the service panels. To access it, remove the outer service panel, then the secondary inner panel to reveal the Bottle Jack.

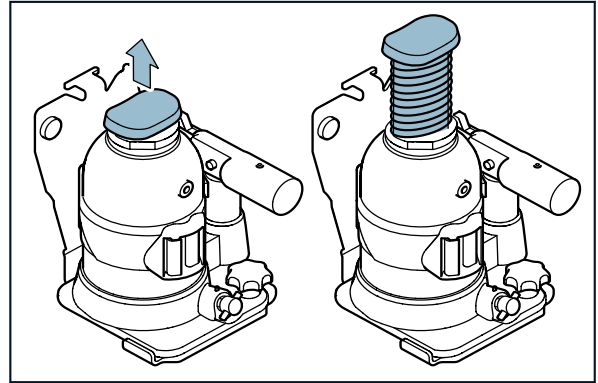
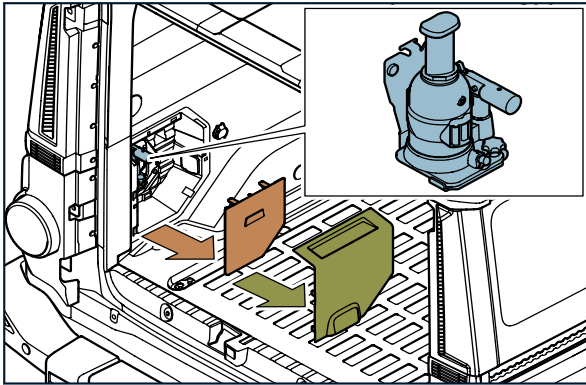

**NOTE:** When securing the Bottle Jack back into place inside the vehicle, it is recommended that the top threaded section of the Bottle Jack is extended upwards. This is to help secure the Bottle Jack into position and eliminates any movement or rattling.



## DRIVER SUPPORT AND FEATURES

For the Quartermaster, the Bottle Jack is located behind the Rear Bench Seat.

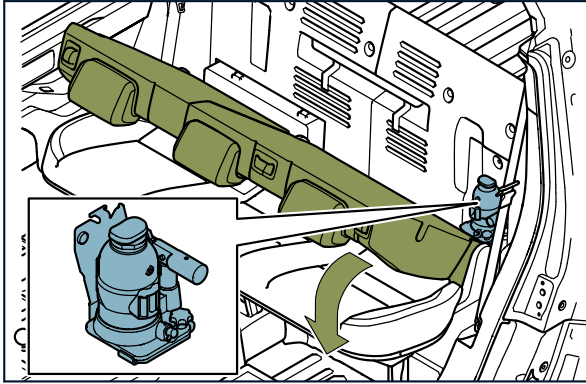

**i** *NOTE: Prior to utilising the bottle jack, inspect it for any signs of damage or wear. If you detect any issues or damage, promptly seek guidance from your INEOS approved partner.*

### Vehicle Jacking

**!** **WARNING: Only use the Bottle Jack to raise the vehicle on firm and level ground. This will ensure stability of both the Bottle Jack and the vehicle.**

**!** **WARNING: The Bottle Jack itself must be located on firm and solid ground. Clear stones or other debris from under the base of the Bottle Jack before use.**

**!** **WARNING: Do not use the Bottle Jack if you are unsure of the jacking point locations on the vehicle. Seek advice and support from an INEOS approved partner.**

**!** **WARNING: Always check there are no objects or persons under the vehicle when using the Bottle Jack at any time. Failure to do this may result in serious injury or death.**

**!** **WARNING: Do not jack up the vehicle with occupants or heavy luggage inside. If towing, always secure and disconnect the trailer before proceeding to use the Bottle Jack. Failure to do so may result in the Bottle Jack failing as the vehicle may be too heavy. This may lead to serious injury or death.**

**i** *NOTE: It is recommended when jacking the vehicle up, that the wheels are chocked and the vehicle is in park P, to help ensure there is no unexpected vehicle movement.*

## DRIVER SUPPORT AND FEATURES

There are designated jacking points on the underside of the vehicle, front jacking points are located on the front axle:

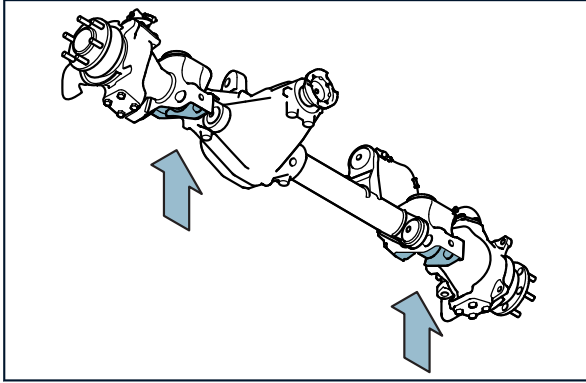

The designated rear jacking points are located on the rear axle:

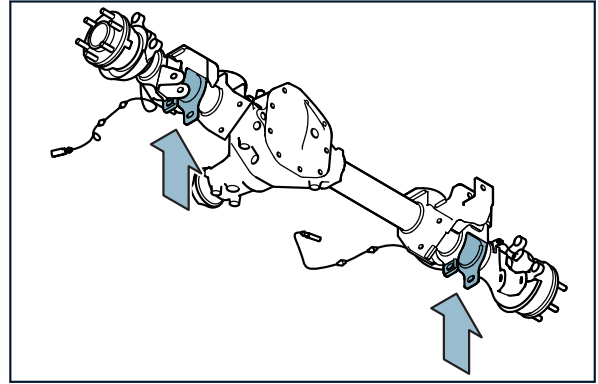

**CAUTION:** The top threaded extension of the Bottle Jack **MUST** be unscrewed to its upper stop position before jacking up the vehicle. This will help prevent the Bottle Jack from touching other parts of the vehicle when in operation. Only when the top threaded section of the Bottle Jack is extended, should the Bottle Jack be used to lift the vehicle.

# DRIVER SUPPORT AND FEATURES

To raise the vehicle using the Bottle Jack:

1. Make sure to close the release valve by turning it fully clockwise.
2. Position the Bottle Jack between the two shock absorber mounting brackets on the axle.
3. Extend the top threaded section of the Bottle Jack, until it can't extend any further.
4. Pump the lever up and down to raise the jack.



*NOTE: Parts under the vehicle may be hot, be careful when under the vehicle. For example, the exhaust can be extremely hot if the vehicle is not allowed time to cool first.*

To lower the jack:

1. Remove all tools and objects from beneath the vehicle, check to make sure there are no people or parts of the body underneath the vehicle.
2. Remove the lever from the bottle jack and slot on to the release valve.
3. Slowly rotate the release valve, anti-clockwise, to slowly lower the vehicle back to the ground, do this carefully to avoid sudden movements of the bottle jack and vehicle.
4. Remove the Bottle Jack when safe to do so.

## VEHICLE RECOVERY



**WARNING: Vehicle recovery and transportation should only be undertaken by personnel with advanced knowledge and qualifications. These tasks are inherently hazardous, and failure to seek assistance from appropriately trained individuals could result in serious injury or even death.**

Your vehicle should primarily be recovered using a vehicle transporter. Towing should be reserved for short distances, such as clearing obstructions or loading onto a transporter. Ensure the transfer case is in neutral by using the neutral screw located on its side before towing.



*NOTE: INEOS recommend that the vehicle is transported with all four wheels off the ground using a flatbed or appropriate wheel lifting equipment. This method is preferable to other types of towing.*

## Front and Rear Towing Eyes

Two Front Towing Eyes are welded to the frame under the front bumper, serving as secure points for towing the vehicle.

Two rear Towing Eyes, welded to the frame under the rear bumper, can tow other vehicles weighing up to a maximum of 3.5 tonnes (7716 lbs).

## DRIVER SUPPORT AND FEATURES

VEHICLE END	TOW HOOK	MAXIMUM LOAD
Front	Horizontal	40 kN (8,992 lbf.)
	Vertical	30 kN (6,744 lbf.)
Rear	Horizontal	35 kN (7,868 lbf.)
	Vertical	22,5 kN (5,058 lbf.)



*NOTE: When towing a trailer using a trailer hitch, the maximum vertical centre load (trailer nose weight) is 350 kg (771 lbs).*

### Emergency Towing - All Four Wheels on the Ground



**WARNING:** When towing the vehicle without the engine running, both the steering wheel and brake pedal will give greater resistance. The brake servo and the steering pump will not engage to provide assistance to the driver. This will mean greater force from the driver will be required to handle the vehicle.



**WARNING:** If the battery needs to be disconnected for any reason, the steering column must be unlocked first. Failure to unlock the steering column lock before disconnecting the battery, will mean the steering column will stay locked during towing. This will result in loss of control, leading to serious injury or death.



**CAUTION:** If there is a fault with the transmission or damage to the wheels and tyres of the vehicle, then the vehicle must not be towed and transported only. Towing a vehicle with transmission faults or a damaged wheel and tyre will cause further damage to the vehicle.



**CAUTION:** Towing with only two wheels on the ground can cause damage to the transmission. Towing with only two wheels on the ground is not recommended.



**CAUTION:** Do not tow the vehicle for a long distance. Towing is a method used for a short distance, for example, to tow the vehicle to a suitable road or to a trailer.



**CAUTION:** The towing speed should not be more than 30 mph (50 km/h) and the towing distance should not be more than 3 miles (5 km).

If it is essential to recover the vehicle by a towing method, such as, towing the vehicle to the roadside for recovery, follow this procedure:

1. Select neutral position in the automatic gearbox.
2. Set the centre differential to the unlocked position.
3. Lift the collar on the transfer case selector and shift to a 'midpoint' between low and high range.
4. Rotate the neutralisation bolt clockwise in order to engage neutral. The bolt is located in the side of the transfer case.

## DRIVER SUPPORT AND FEATURES

5. Turn the key in the ignition barrel to position one, this will then unlock the steering column.
6. Release the handbrake.



*NOTE: The key must remain in position while towing, do not try to change the position of the key in the ignition barrel, until towing has finished and the vehicle is stationary.*



**CAUTION:** Leaving the ignition on while towing will drain the battery, the vehicle lamps will activate for braking and directional indicating. Only drive short distances when towing the vehicle.

### Transporting The Vehicle



**WARNING:** Transporting a vehicle requires extreme caution and professional assistance to avoid danger. Improper handling can lead to serious injury or death.

Secure the vehicle safely before transportation, using qualified professionals for recovery and transport. A trailer designed for this vehicle is recommended.

### Front (OPTIONAL) and Rear (ACCESSORY) Winch



**WARNING:** Before using the winch, inspect for damage or signs of wear. Failure to do this may result in damage to the vehicle, serious injury or even death.



**WARNING:** Use the winch only for self-recovery purposes, avoiding misuse. Incorrect usage can damage the winch, its components, and the vehicle, potentially leading to serious injury or death.

Before using the winch, the following inspections must be completed:

- > Winch should be well maintained and visually in good condition
- > Motors should not be exposed
- > All fasteners and connections must be checked
- > The Winch Rope must be inspected for signs of wear, such as, damage, cuts, and fraying.

For further details, please refer to the Winch Handbook document supplied with the vehicle and/or available online.

## DRIVER SUPPORT AND FEATURES

### Jump Starting The Vehicle

 **WARNING:** The donor vehicle must have a battery with the same volts, the battery is 12 volts. Failure to do this may result in serious injury or death.

 **WARNING:** Do not start the vehicle with a quick charger.

 **WARNING:** When connecting the negative jump lead to the grounding point, do not use the fuel lines, engine rocker covers or the intake manifold as grounding points.

 **WARNING:** Make sure that there is sufficient ventilation when charging the battery or jump starting the vehicle.

 **WARNING:** Do not connect a positive (+) terminal to a negative (-) terminals on the battery directly. This will cause serious injury or death. There are terminal points under the bonnet that must be used.

 **WARNING:** Do not allow the terminals of one lead to touch those of the other lead.

 **WARNING:** When using booster cables between both vehicles, be careful not to get the cables tangled or caught on any moving mechanical parts causing damage

to the vehicle. If the cables do get caught, then this may result in serious injury or death.

 **CAUTION:** Connect batteries with only the same nominal voltage.

 **CAUTION:** If the battery does not hold charge after a jump start from a donor vehicle, then the vehicle must not be driven until the vehicle has been checked by an approved INEOS partner. Repeatedly jump starting the vehicle can cause further damage.

To jump-start a vehicle with a depleted battery, access the battery located under the rear bench seat. Positive and negative terminals in the engine bay provide connection points for jump leads.

Before jump starting the vehicle please be aware of the following points:

- > Use jump leads with insulated terminals and a cross section of at least 16 mm<sup>2</sup> (25 mm<sup>2</sup> for diesel engines).
- > Do not disconnect the discharged battery from the vehicle.
- > A discharged battery, can freeze at a temperature of 0 °C (32 °F). Defrost the frozen battery before connecting jump leads.
- > Switch off all unnecessary electrical consumers.
- > The vehicles must not come into contact with each other during the jump starting process.

## DRIVER SUPPORT AND FEATURES

- > Apply the handbrake, transmission in neutral, automatic transmission in **P** (if applicable) to both vehicles.
- > Open the red positive terminal protection caps off both positive terminals or batteries (if applicable).

When safety warnings have been considered and the necessary safety equipment and clothing has been prepared, the vehicle can be jump started.

### Jump Start Procedure

1. Park the donor vehicle as close as possible, The vehicle battery post should be adjacent to the donor vehicle battery, this reduces the space that the jump cables need to cross to connect the vehicles.
2. Make sure the handbrake is applied to both vehicles.
3. The donor vehicle should be in neutral gear or park **P** if automatic.
4. Make sure both vehicles are switched off.
5. Connect the positive (+) cable to the positive (+) terminal, on the donor vehicle battery. Then connect the other end of the positive (+) cable to the positive (+) battery post on the vehicle with the depleted battery.
6. Connect the negative (-) cable to the negative (-) terminal on the donor vehicle.



**WARNING: Do not connect the last remaining negative (-) cable to the negative (-) terminal on the vehicle with the**

**discharged battery. Only connect the last remaining negative (-) cable to an earth point for safety reasons.**

7. Connect the last remaining negative (-) connector, to an earth point, on the vehicle with the discharged battery.
8. Check the connections are secure and in the correct positions. Check that the cables are not caught on any moving or mechanical parts. Now start the donor vehicle engine and run at about 1500-2000 rpm for two to three minutes.
9. Now start the vehicle with the discharged battery, allowing both engines to run together for a further two minutes.
10. Switch the donor vehicle off.
11. Disconnect the negative (-) cables first, followed by the positive (+) cables from both vehicles.
12. Allow the vehicle with the depleted battery to idle for a while longer, this is to let the battery recharge.

It is recommended, to switch off the vehicle that originally had the depleted battery. Then try to restart the vehicle to see if the engine will restart again. If the vehicle restarts, this confirms the battery is recharging when the engine is running. Take the vehicle on a long drive to fully recharge the battery.

If the vehicle does not restart after the jump start procedure has been followed, consult with your INEOS approved partner to have the battery and/or the charging system checked and replaced if necessary.

# DRIVER SUPPORT AND FEATURES

## TOWING A TRAILER



**WARNING:** Always avoid the space between the vehicle and the towed object, like a trailer, when towing to prevent the risk of injury or fatality.



**WARNING:** Attach a trailer to the trailer hitch only. Attaching a trailer to any other part of the vehicle can result in reduced handling and loss of control.



**CAUTION:** Maximum towing weight of a braked trailer is 3500 kg (7716 lbs). Do not exceed this towing weight.

Ensure that the trailer is utilised in line with the manufacturer's guidelines and adheres to relevant legislation.

## TOWING CAPACITY



**CAUTION:** Maximum towing weight of a braked trailer is 3500 kg (7716 lbs). Do not exceed this towing weight.



**CAUTION:** Do not use high range when travelling at speeds less than 20 mph (32 km/h), while towing heavy loads. Otherwise the transmission may overheat. It is advised to use low range below 20 mph (32 km/h) when towing heavy loads.

### TOWING CAPACITY

TOWING CAPACITY	
Braked Towing	3500 kg (7716 lbs)
Unbraked Towing	750 kg (1653 lbs)
Nose Weight	350 kg (771 lbs)
Vertical Max. Load on the Towing Hitch	350 kg (771 lbs)

### Trailer Stability Assist

Specific Electronic Stability Control (ESC) calibration for use when towing. Trailer Stability Assist helps to control individual wheel slip, to prevent potential trailer sway.

The vehicle ESC must be in default mode for Trailer Stability Assist to operate. When Trailer Stability Assist is triggered, the tell-tale  will flash to warn the driver.



# ADVANCED DRIVER ASSISTANCE SYSTEMS (ADAS)

---

ADVANCED DRIVER ASSISTANCE SYSTEMS (ADAS) (If Applicable) ..... 122

AUTOMATIC EMERGENCY BRAKING (AEB) (If Applicable) ..... 124

DRIVER DROWSINESS DETECTION (DDD) AND WARNING (If Applicable) ..... 127

LANE DEPARTURE WARNING (LDW) (If Applicable) ..... 129

INTELLIGENT SPEED ASSIST (ISA) (If Applicable) ..... 132

# ADVANCED DRIVER ASSISTANCE SYSTEMS (ADAS)

## ADVANCED DRIVER ASSISTANCE SYSTEMS (ADAS) (If Applicable)



**WARNING:** The driving systems act as aids but are not substitutes for your awareness of your surroundings. They do not absolve you of your responsibility under road traffic laws. The driver always bears the responsibility of maintaining a safe distance from the vehicle ahead, controlling vehicle speed, braking in a timely manner, and staying within the lane.



**WARNING:** Driving systems cannot mitigate the risk of accidents if you fail to adjust your driving style, nor can they defy the laws of physics.



**WARNING:** The Advanced Driver Assistance System is designed solely to assist the driver. The driver retains full responsibility for controlling the vehicle at all times. Failure to maintain control may lead to vehicle damage, injury, or death.



**WARNING:** Weather conditions can affect the accuracy of the system. Always remain in control of the vehicle and do not rely on the system to operate the vehicle for you.



**WARNING:** Do not block the Front Camera and ensure there is always a clear field of view. Make sure the window screen in front of the camera is clear of dirt and/or obstructions. This includes sun/glare strips and/or window screen films and stickers.



**WARNING:** If the centre differential lock is activated, all ADAS functions are automatically deactivated.



**WARNING:** Window screen damage such as, cracks and stone chips can affect the functionality of the system if they are in the camera field of view. Consult with an INEOS approved partner if you have damage to the window screen and/or the system is not working correctly.



**WARNING:** Objects on the bonnet and big dimension objects on the roof can interfere with the Front Facing Camera's performance. It is the driver's responsibility to keep a clear line of sight for the Front Facing Camera.



**WARNING:** Immediately consult with your nearest INEOS approved partner, if you suspect a system fault.

The Advanced Driver Assistance System includes: Intelligent Speed Assist, Lane Departure Warning, Automatic Emergency Braking and Driver Drowsiness Detection.

### ADAS Settings and Tell-Tale Lamps

The ADAS settings can be configured within the infotainment system. Using the infotainment screen, press 'SETTINGS', followed by 'Vehicle Functions' and then 'ADAS'.

# ADVANCED DRIVER ASSISTANCE SYSTEMS (ADAS)

The 'ADAS' menu consists of the following:

- > Automated Emergency Brake.
- > Lane Departure Warning.
- > Intelligent Speed Assist.
- > Driver Drowsiness Warning.
- > Deactivate all ADAS Functions.

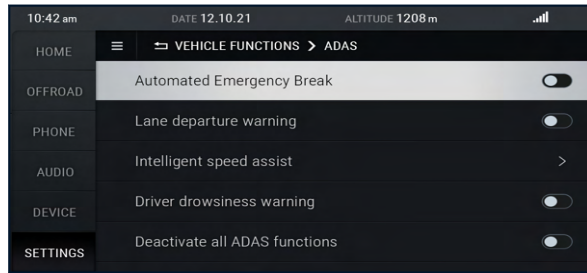

All ADAS functions can be deactivated by pressing the 'Deactivate all ADAS functions' toggle once.

When pressed, there will be a pop up message asking to confirm the option selected.

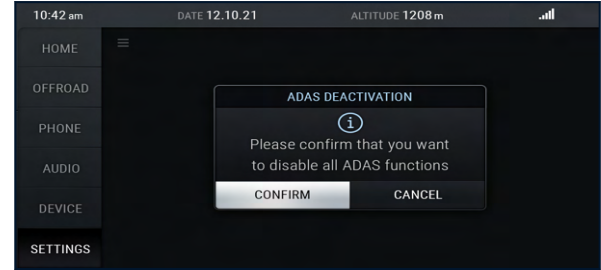

*NOTE: The option to 'Deactivate all ADAS functions' will be greyed out, if the vehicle is travelling at speeds higher than 6mph (10km/h).*

## Front Camera



**WARNING: Immediately consult with your nearest INEOS approved partner if you suspect a system fault.**

The vehicle features a Front Camera installed in the front windscreen to bolster safety and assistance functions, including Autonomous Emergency Braking (AEB), Intelligent Speed Assist (ISA), and Lane Departure Warning (LDW).

## ADVANCED DRIVER ASSISTANCE SYSTEMS (ADAS)

If the camera view becomes obstructed momentarily, a warning message 'Front Camera View Limited' will appear on the infotainment screen.



If the camera remains obstructed for an extended period or encounters an error, the warning 'ADAS malfunction' will be displayed on the infotainment screen.



*NOTE: If an ADAS malfunction occurs and the ADAS malfunction warning is visible, ADAS systems will not be available.*

### AUTOMATIC EMERGENCY BRAKING (AEB) (If Applicable)



**WARNING:** AEB is for driver assistance only. The driver is responsible for vehicle control. Lack of control may result in damage, injury, or death.

# ADVANCED DRIVER ASSISTANCE SYSTEMS (ADAS)

Automatic Emergency Braking (AEB) is a safety feature that monitors traffic and road conditions to alert the driver of potential dangers. Using a camera, AEB helps prevent accidents by analysing the vehicle's speed and trajectory. If the driver fails to respond promptly to a detected hazard, the AEB system automatically applies the brakes to reduce the vehicle's speed, potentially preventing or mitigating the severity of a collision.

## Forward Collision Warning (FCW)



**WARNING:** The Forward Collision Warning system is designed to detect cars, vans, trucks, and certain motorbikes. It does not react to scooters, cyclists, pedestrians, or animals. Exercise caution and remain vigilant while driving the vehicle.

When the AEB system identifies a potential danger, it issues a Forward Collision Warning (FCW) to the driver. The FCW includes both an audible and visual warning. The visual alert comprises a red illuminated tell-tale lamp  and a warning symbol on the

infotainment screen. Simultaneously, the driver will hear a warning sound when the visual warnings are displayed.



The FCW remains active until the AEB operation is complete. If the driver makes a hard steering manoeuvre, accelerates, or presses and releases the brake pedal, both FCW and AEB are aborted.

## Forward Autonomous Collision Mitigation (FCW/AEB)

FCW and AEB will operate in the following conditions:

- > Speed range of 6-80 mph (10-130 Km/h).
- > Electronic Stability Control (ESC) is fully active.
- > Off-road Mode / Wading Mode deactivated.
- > Differential lock is not engaged.

# ADVANCED DRIVER ASSISTANCE SYSTEMS (ADAS)

There are limitations to the system as listed below:

- > Cold or severe weather (Snow, Ice, Rain, Spray and Fog).
- > Limitations in hazard detection due to low or direct sunlight, low light and unconventional vehicle types.
- > System does not react to Scooters, cyclists, pedestrians, and animals.
- > System will not operate under hard steering or acceleration.

There are two sub functions, as seen below:

- > Forward Collision Warning.
- > Autonomous Emergency Braking.

## AEB And FCW - Activation and Deactivation



**WARNING:** If you suspect a system fault, it's important to consult with your nearest INEOS approved partner immediately.

The system is automatically activated when the vehicle is started. However, the driver can manually deactivate or reactivate the FCW and AEB features by accessing the 'ADAS' menu on the infotainment

screen. Manual deactivation and activation are only possible when the vehicle is travelling at less than 6 mph (10 km/h).

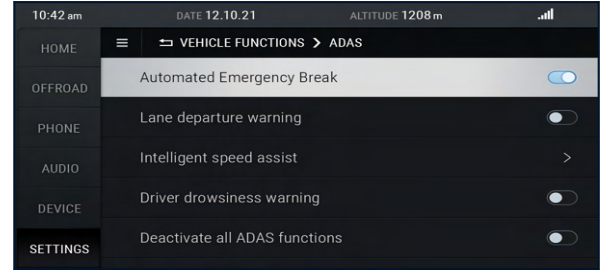

The driver will be prompted to confirm the deactivation of AEB when pressed. This serves as a fail-safe to prevent accidental deactivation of the system.



# ADVANCED DRIVER ASSISTANCE SYSTEMS (ADAS)

If the FCW and AEB functions are manually deactivated by the driver or there is a system error, a visible warning will appear on the infotainment screen accompanied by an illuminated tell-tale lamp.



## DRIVER DROWSINESS DETECTION (DDD) AND WARNING (If Applicable)



**WARNING:** Driver Drowsiness Detection (DDD) is a driver support feature meant to enhance safety. However, the driver remains responsible for controlling the vehicle at all times. Failure to do so may result in damage, injury, or even death.

Driver Drowsiness Detection (DDD) evaluates the driver's level of alertness by analysing vehicle systems, providing warnings when necessary. If required, the driver will receive visual alerts on the infotainment screen and audible warnings, signalling the need to take a break at the next safe opportunity.



## DDD - Activation

The DDD system is automatically activated when the engine is turned on.

The system will effectively monitor the driver's drowsiness level. However, its accuracy may be reduced when driving within a city or off-road, and at speeds exceeding 80 mph (130 km/h). Drivers are responsible for assessing their own fitness to drive and should take regular breaks during long journeys.

# ADVANCED DRIVER ASSISTANCE SYSTEMS (ADAS)

## DDD - Deactivation

The Driver Drowsiness Warning can be deactivated manually using the infotainment screen. Navigate to the 'ADAS' menu and press the 'Driver Drowsiness Warning' toggle once.

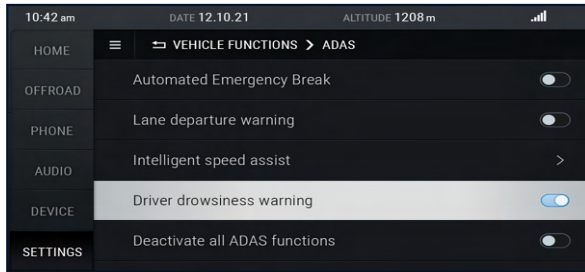

The driver will be prompted to confirm their intention to deactivate the Driver Drowsiness Warning feature. Additionally, DDD may be automatically deactivated in certain circumstances, such as when the vehicle is switched into Off-Road Mode. When the DDD feature is deactivated, an orange tell-tale symbol will illuminate to alert the driver .

The system will automatically reactivate once the conditions that caused its deactivation are no longer present.

## DDD - Error



**WARNING: If you suspect a system fault, it's essential to promptly consult with your nearest INEOS approved partner for assistance.**

Upon vehicle start-up, the system will conduct a comprehensive check to ensure proper functionality. If any errors or malfunctions are detected, the driver will be promptly notified of the issue.

Upon error detection, a visual warning will display on the infotainment screen along with an orange illuminated tell-tale lamp. The Driver Drowsiness Warning toggle in the ADAS menu will be greyed out, indicating its unavailability.

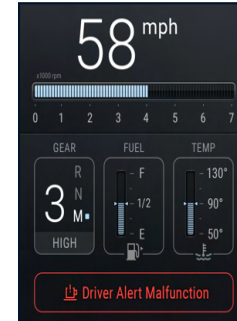



# ADVANCED DRIVER ASSISTANCE SYSTEMS (ADAS)

## LANE DEPARTURE WARNING (LDW) (If Applicable)



**WARNING:** Lane Departure Warning (LDW) is intended solely for driver support. It's crucial for drivers to maintain control of the vehicle at all times, as failure to do so could lead to vehicle damage, injury, or death.

LDW alerts the driver when the vehicle deviates from its lane. Using the Forward Facing Camera, it detects lane markers like painted stripes. If the vehicle approaches lane boundaries without a turn signal, prompting the driver to adjust course.

### LDW Activation

LDW is automatically activated by default in each ignition cycle.

LDW provides both audible and visual warnings when the vehicle exceeds 40 mph (65 km/h) and veers too close to lane markings.

Visual alerts appear on the infotainment screen, where dashed green lines indicate successful detection of road markings.



## ADVANCED DRIVER ASSISTANCE SYSTEMS (ADAS)

The following image shows dashed grey lines.



The orange line in the image indicates that the vehicle is approaching the road markings on the left side of the lane.



The appearance of dashed grey lines on the infotainment screen may be due to the following conditions:

- > Speedometer speed is less than 37mph (60km/h).
- > Full release of the accelerator pedal.
- > Activation of the turn indicator or hazard lamps by the driver.
- > Curvature is above the threshold.
- > Inappropriate lane width.
- > Electronic Stability Control (ESC) intervention.
- > Exceeding lateral velocity threshold.

# ADVANCED DRIVER ASSISTANCE SYSTEMS (ADAS)

## LDW Deactivation

To deactivate LDW, go to the 'ADAS' menu on the infotainment screen and toggle the 'Lane Departure Warning' feature option.

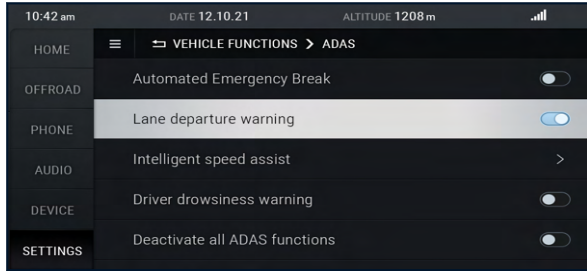

The system will automatically deactivate under certain conditions, such as when activating Off-Road Mode, Wading Mode, or when the differential lock is engaged. It will reactivate automatically once the conditions that caused its deactivation are no longer present.

If the system is manually deactivated, the grey lines representing road markings on the infotainment screen will disappear. The tell-tale  will be illuminated orange to confirm deactivation.

## LDW Error



**WARNING: Immediately seek assistance from your nearest INEOS approved partner if you suspect a system fault.**

Once the vehicle is started, the system checks all functions for correct operation. If there's a malfunction with the LDW system, the driver will see a visual warning on the infotainment screen and an orange illuminated tell-tale lamp .



If there's a malfunction or error with the system, the Lane Departure Warning option will be greyed out.

# ADVANCED DRIVER ASSISTANCE SYSTEMS (ADAS)

## INTELLIGENT SPEED ASSIST (ISA) (If Applicable)



**WARNING:** Intelligent Speed Assist is intended for driver support only. The driver retains responsibility for controlling the vehicle in all situations. Failure to maintain control of the vehicle may result in damage, injury, or death.

Intelligent Speed Assist (ISA) detects road signs on both sides of the road, including overhead signs, to provide drivers with helpful information. If the vehicle's speed exceeds the detected speed limit, ISA issues both an acoustic and visual warning. Additionally, the system utilizes a local map database (NDS map) to improve performance in areas where speed limit signs are not visible.

### ISA Activation

The system will be activated at the start of each ignition cycle by default.

When a road sign is detected, the system will display the sign to the driver on the infotainment screen, as shown in the example images.



# ADVANCED DRIVER ASSISTANCE SYSTEMS (ADAS)

If the speed limit is not available, then a sign or speed limit will not be displayed.

## ISA Limited

The driver will be notified with a warning on the infotainment screen, when the system is set to limited operation.



The system will be limited if any of the following occur:

- > Unknown road from NDS map or there is a map data error.
- > Vehicle is driven on a private road.
- > Vehicle is driven off-road.
- > Camera is dirty or the field of view is obstructed.
- > Country code is not supported.



*NOTE: The system is able to automatically detect the country-code and set it without user confirmation.*

## ISA Overspeed Warning

If the speedometer speed exceeds the perceived speed limit, the speed sign image on the infotainment screen will flash. Should the vehicle continue to exceed the speed limit, an acoustic warning will sound. The warning is triggered by factors, such as, the percentage of speed above the limit or the duration of speeding.

The visual warning flashes when the speedometer speed surpasses the perceived limit and continues until the vehicle's speed matches or falls below the limit. If the driver intentionally slows down, the system detects this and stops the visual warning.

If the driver maintains speeds above the perceived limit without decelerating, the acoustic warning ceases while the visual warning persists.

## ISA Speed Change Notification

When the system detects a new road sign indicating a change in the speed limit, the system will alert the driver with an audible sound.

The speed change notification settings can be switched ON or OFF in the settings. However, the system will store the last chosen option until the setting is changed again. As the Speed Change Notification is set to OFF by default, the driver will need to navigate the infotainment screen to the setting to activate this option. There is no default ON or OFF at the start of each ignition cycle for this option, the car will store the last chosen preference.

# ADVANCED DRIVER ASSISTANCE SYSTEMS (ADAS)

## ISA Deactivation

The driver can toggle the ISA options by navigating to the 'ADAS' Menu, followed by a single press on the 'Intelligent Speed Assist' option.

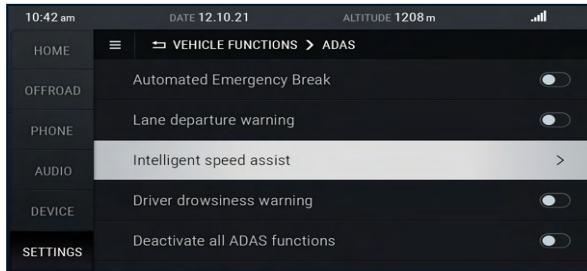

In the 'Intelligent Speed Assist' menu, toggle the following options ON or OFF: Speed limit info, Overspeed Warning, Speed change warning.

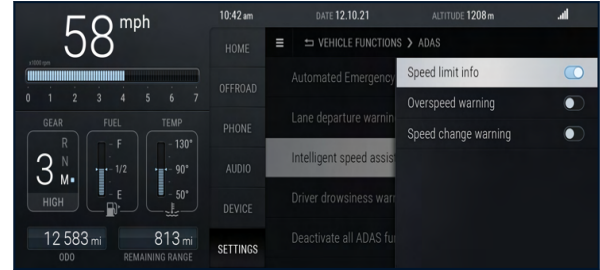

The system automatically deactivates in certain circumstances, like activating Off-Road Mode, and re-activates when those conditions cease.

If the system is deactivated, an orange illuminated tell-tale lamp  will appear, and no speed sign will be shown.

## ISA Error



**WARNING:** Immediately contact your nearest INEOS approved partner if you suspect a system fault.

After each vehicle start-up, the system verifies all conditions to ensure proper functioning. If any malfunctions or errors are detected, a visual warning will appear on the infotainment screen.

# ADVANCED DRIVER ASSISTANCE SYSTEMS (ADAS)

This warning includes a brief text description and a yellow road sign image without any speed displayed.



If any malfunction or error occurs with the ISA system, the driver will receive a visual warning on the infotainment screen, accompanied by an orange illuminated tell-tale lamp .

If a malfunction or error occurs with the system, the Intelligent Speed Assist Warning option will be greyed out.

## ISA - Update Maps

To update the infotainment system with the latest maps, go to the "GENERAL" menu in the "SETTINGS" tab. Select "Update NDS map" to view the current NDS map version and a QR code.

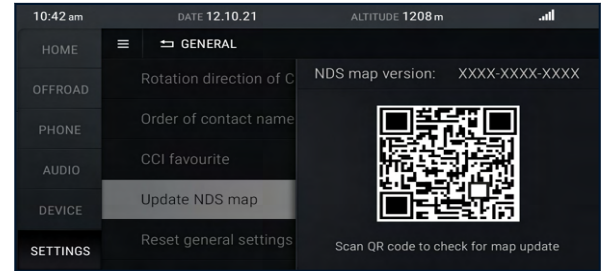

Alternatively, the following link: <https://grenadier.mapupdate.info/>

To proceed with the download:

1. Download the ZIP file from the provided link.
2. Using a USB drive formatted as FAT32, extract the files from the downloaded ZIP file and copy the dbupdate directory to the USB drive.



*NOTE: There should only be one dbupdate folder on the USB drive at one time.*

## ADVANCED DRIVER ASSISTANCE SYSTEMS (ADAS)

---

3. Using the Infotainment Screen, navigate to "ISA Maps Update".
4. Insert the USB device into the USB connector within the vehicle.
5. Follow the instructions on the infotainment screen.



*NOTE: For assistance with updating your vehicle's maps, please contact your INEOS approved partner.*



## MEDIA AND INFOTAINMENT

---

OVERVIEW .....	138
HOME .....	144
OFF-ROAD .....	147
PHONE .....	150
DEVICE .....	155
AUDIO .....	158
SETTINGS .....	163
AUDIO OUTPUT SPECIFICATION .....	168
CONNECTIVITY .....	168

# MEDIA AND INFOTAINMENT

## OVERVIEW



**WARNING:** Driving while distracted may result in a crash. Remain vigilant at all times and pay attention to the road and your surroundings. Failure to do so can result in serious injury and even death to you and others around you.

## Central Control Interface (CCI)

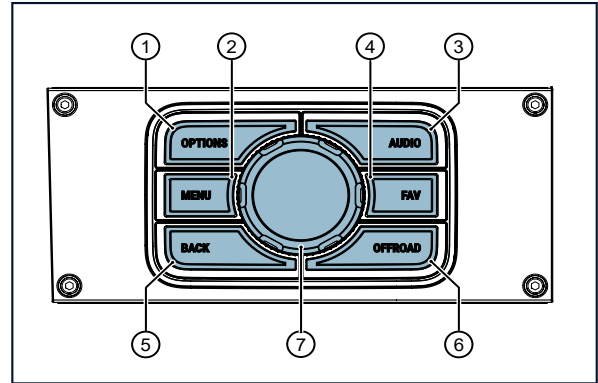

NUMBER	BUTTON	DEFINITION
1	OPTIONS	Opens or closes the option menu of the active area/focus.
2	MENU	Opens and closes the menu of the active area/focus.
3	AUDIO	Opens the audio menu.
4	FAVOURITE	Default switches to radio, can be changed in the settings.
5	BACK	Returns back to previous option or screen.
6	OFFROAD	Infotainment enters off-road screens.

## MEDIA AND INFOTAINMENT

NUMBER	BUTTON	DEFINITION
7	ROTARY CONTROLLER	Directional movement, by moving left, right, up and down or rotating the rotary controller. Press inwards once, like a button, to confirm current selection.

To switch focus, such as, moving from the favourites bar to the radio frequency option, rotate the rotary controller.

To select the currently highlighted item, push the rotary controller inwards once. You can rotate the rotary controller to select items within the currently active window.

Pushing or pulling the rotary controller from side to side, will switch the focus between the available windows. When using the touch

function you can press the buttons directly or scroll up and down by swiping up and down.

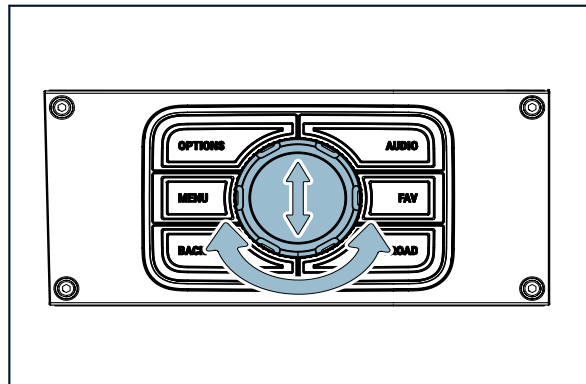

If the last item of the window is reached, pressing the down button will do nothing, the user will have to navigate in the reverse order.

# MEDIA AND INFOTAINMENT

## STEERING WHEEL CONTROLS

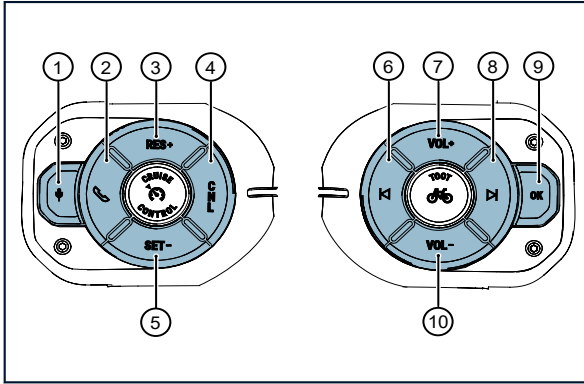

1. Voice activation ( Apple CarPlay and Android Auto only)
2. Start and end calls
3. Incremental increase
4. Cancel
5. Incremental decrease
6. Previous track
7. Increase volume
8. Next track

9. OK - Confirm selection
10. Decrease volume

## VOLUME AND MUTE

To mute the audio, press the mute button (9), located on the centre console. Press the mute button again, to un-mute the audio. Rotate the audio knob surrounding button (9), to adjust the audio volume.

Alternatively using the steering wheel controls, press button (7) to increase the volume or button (10) to decrease the volume.

## HIGHLIGHT CURSOR

The highlight cursor is used when navigating with the infotainment screen to indicate the current position of the user.

No highlight cursor:

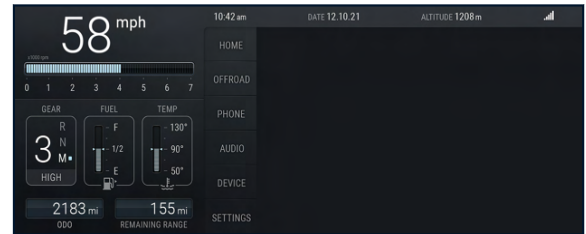

# MEDIA AND INFOTAINMENT

Highlight cursor:

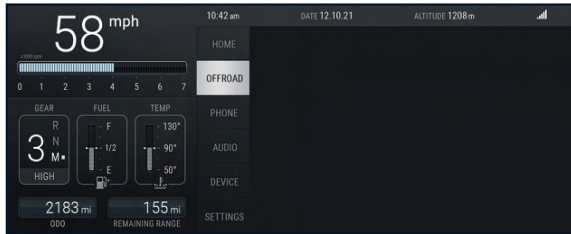

Pressed highlight cursor:

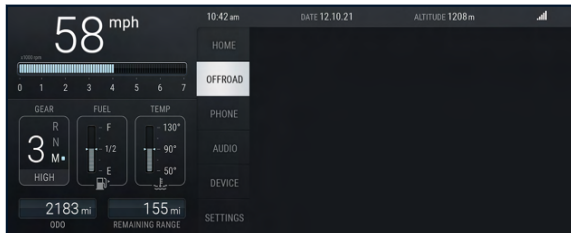

Active/selected option:

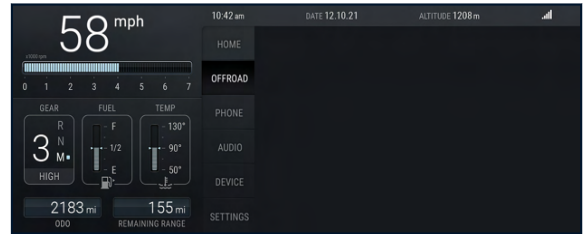

By default, the highlight cursor will be visible on the 'HOME' menu tab. When navigating through the menu, the highlight cursor will be on the selection that was last activated in that menu.

The highlight cursor will be greyed out if a selection is not possible.

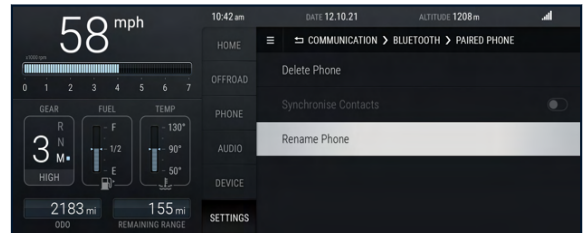

*NOTE: If there is an issue with the system, such as, a failed connector or sensor issue then '-' will be shown*

# MEDIA AND INFOTAINMENT

*instead of the value. If this happens contact your INEOS partner for further support.*

## OPTIONS MENU

The option menu can be opened, by either touching the option menu button next to the 'HOME' tab on the infotainment screen or by pressing the 'OPTIONS' button (1) on the CCI.



The options menu can be closed by pressing the button a second time, pressing the 'OPTIONS' button on the CCI, or by pressing the 'BACK' button (5) on the CCI.



**NOTE:** *The option menu button will be greyed out if it is not possible to select or open. For example, when inside the setting menu, the options button will not be selectable.*

When opening the option menu, continue to use the rotary controller to navigate the options available.

## NAVIGATION BAR

There is a navigation bar at the top of each menu, showing your current location within the menu structure. Every time the user selects an option, the navigation bar displays the route taken and the names of the options selected so far.

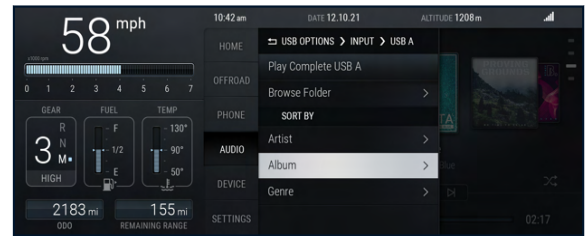

When there is not enough space to display the names of selected options, the navigation bar will replace the route names with arrows. The arrows will indicate the level of the menu structure selected so far.

# MEDIA AND INFOTAINMENT

This image is an example of 'USB OPTIONS' and 'INPUT' hidden as the first two arrows:

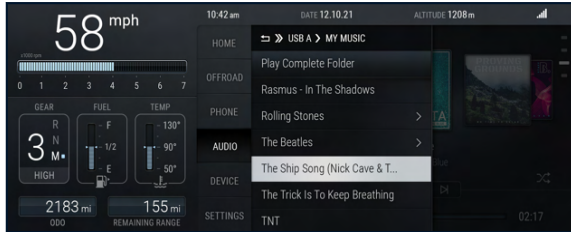

This image is an example of 'USB OPTIONS', 'INPUT' and 'USB A' hidden as the first three arrows:

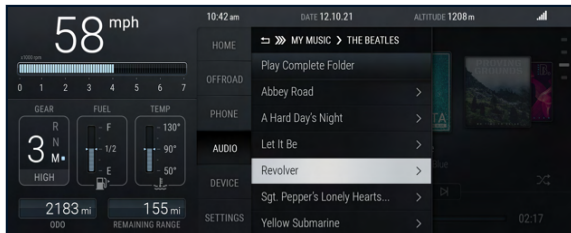

## KEYBOARD

The keyboard will appear, once an option that requires input is selected.

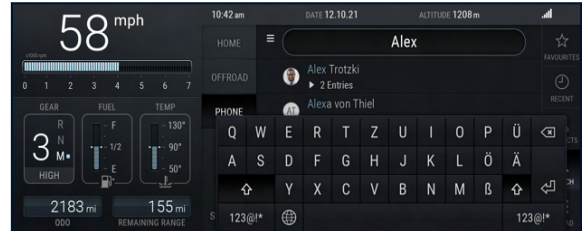

If the field that requires the input is not visible, an input box will appear above the keyboard.

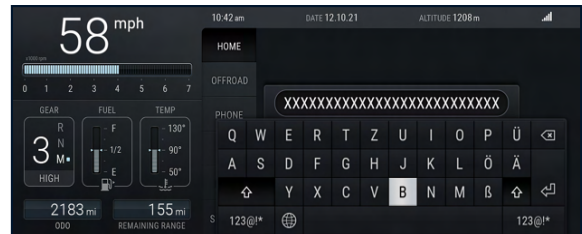

To close the keyboard, press the 'BACK' button on the CCI or touch anywhere outside the keyboard.

# MEDIA AND INFOTAINMENT

When the user selects the globe symbol on the keyboard, an overlay will appear with the options to change the keyboard layout.

## INFORMATION HEADER

The info bar is visible at the top of the infotainment screen. The info bar displays information, such as, time, date, altitude and phone signal.

## HOME

The home tab is subdivided into two sections, also referred to as a focus. The top section is the audio focus, showing audio information, such as, currently playing and upcoming tracks in the play list. The bottom section is favourites focus, showing contacts from a connected mobile phone.



By default, the audio focus will be visible, however the system will remember the last focus selected. For example, if the user navigates

from browsing the favourites focus, to the 'SETTINGS' tab, then returns again to the 'HOME' tab, the favourites focus will continue from the position last used.

If there is no favourite contacts available to display in the favourites focus, then text, such as, 'No Favourite Contact' will be displayed.

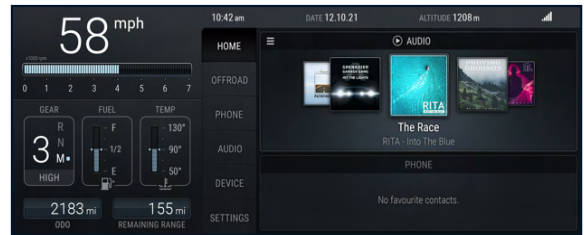

If there is no audio play list available, the audio focus will display text stating 'No Playlist'.

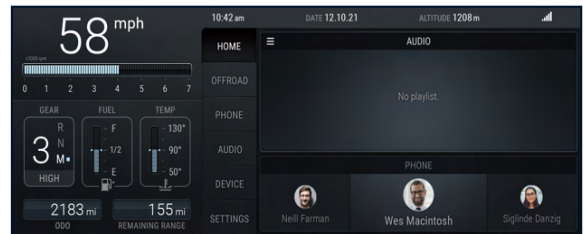



# MEDIA AND INFOTAINMENT

## Home Audio

When the audio focus is active, depending on the source of the audio, the user will see the following displays within the 'HOME' tab:

FM/AM radio with one information line displaying frequency.



DAB displaying album cover (if applicable), with two lines of information. Line one, showing the station name and line two, showing the Frequency.



Bluetooth device displaying album cover (if applicable), with two lines of information. Line one, showing the track name, line two, showing the artist and album name.



USB device displaying album cover (if applicable), with two lines of information. Line one, showing the track name and line two, showing the artist and album name.

The active track being played, will always be positioned in the centre of the audio focus.

# MEDIA AND INFOTAINMENT

If the user selects the favourite focus, while the audio focus is active, then the favourite focus will enlarge to indicate screen priority. The audio focus will decrease in size.



The middle contact of the three contacts simultaneously shown will be highlighted, revealing contact numbers listed for that specific contact.

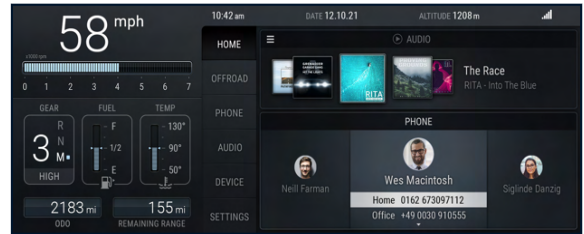

## Favourites

The favourites focus shows contacts from connected mobile phone. The favourite focus will display a maximum of three contacts simultaneously. If there are more than three favourite contacts then the user can swipe through the list using the touch screen or the rotary controller.

If there are multiple numbers for a contact, a small downwards arrow will appear. Scroll down the list to reveal more numbers using the rotary controller, touchscreen or steering wheel controls.

If there is no mobile phone connected, then the favourite focus will display text, such as, 'No phone connected. Please go to settings.'

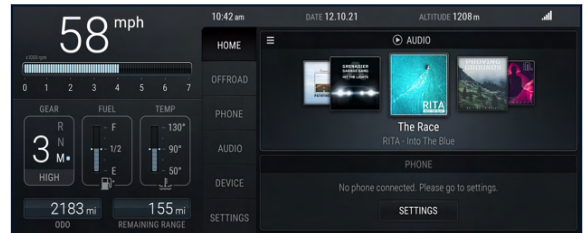

## OFF-ROAD

### Attitude

Selecting the 'OFFROAD' mode tab, displays a menu of features relevant to using the vehicle off-road. The first sub-tab is the attitude screen, displaying the following information:

- > Wheel angle.
- > Altitude.
- > G-Force.
- > Pitch.
- > Roll.



### Off-Road Temperature

The second sub-tab, will display temperature information, such as:

- > Tyre pressures of all four tyres in use, this excludes the spare wheel tyre.
- > Tyre temperatures of all four tyres in use, this excludes the spare wheel tyre.
- > Engine temperature.
- > Automatic transmission gearbox temperature.
- > Two-Speed Transfer Case temperature.



# MEDIA AND INFOTAINMENT

## Pathfinder Navigation Mode

The third sub-tab is the pathfinder navigation mode. The screen will consist of the home button near the top and three further options, such as, 'Record Path', 'Follow Path' and 'Roadbook'.

- > Follow Path - Follow an existing GPX document.
- > Record Path - Record and create a new GPX document.
- > Roadbook - Manually record a route.

## Follow Path

After recording the required path, the user can follow it by utilising the recorded waypoints. Clicking on the next way point prompts the compass to guide the user in the required direction. While following the compass, the user can track the distance to the next selected waypoint.



Users can navigate to the next or previous waypoints by pressing the 'NEXT WAYPOINT' or 'PREVIOUS WAYPOINT' buttons on the infotainment screen. They can also select waypoint markers on the route line by pressing the screen or using the rotary controls.

## Record Path

The record path screen, may be used to record the path driven manually or automatically.

The user can add a way point by clicking on the record path button, otherwise the user can add a way point automatically. To automatically add way points over set distances, the user should switch on the automatic feature inside the menu options.

In the image below, the compass shows the direction of travel and the distance travelled.



# MEDIA AND INFOTAINMENT

## Roadbook

The roadbook feature is used for rally driving and driving off-road. The passenger can compare the roadbook to a hand-held roadbook for the planned trip. The user can adjust the distance between points, by using the minus or plus buttons on the infotainment screen. Press the minus or plus buttons, to decrease and increase the distance in increments of 100 meters (328 ft). This is done by pressing the buttons on the infotainment screen or by using the rotary controls.



'TOTAL TRIP' is the total distance to be travelled and the 'PARTIAL TRIP' is the distance to be travelled to a checkpoint, thus helping the passenger understand the distance travelled so far.

## Statistics

The fourth sub-tab, will display statistics information, such as:

- > Latitude.
- > Longitude.
- > Altitude.
- > Travel time.
- > Travel Distance.
- > Average Speed.
- > Average Fuel.



# MEDIA AND INFOTAINMENT

## Off-Road Electrical

The fifth sub-tab, will display electrical information, such as:

- > Current charge.
- > Battery temperature.
- > Voltage.
- > State of charge.

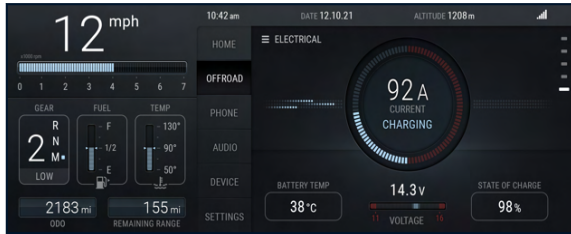

## PHONE

Mobile phones can be connected to the infotainment system using Bluetooth. The user can make calls, play stored music or use the mobile phone device for navigation purposes.

Select the 'PHONE' tab on the infotainment screen, using the touch screen or the rotary controller, to open the 'PHONE' section. When the 'PHONE' tab is selected, the system will show any connected

devices. If there is no phone connected, a 'SETTINGS' button will be visible with a message stating 'No phone connected. Please go to settings'.

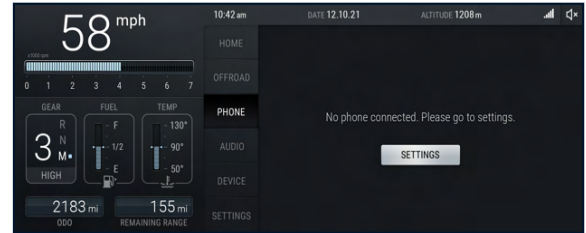

## Connecting Phone

If there is no phone connected, the infotainment screen will show a 'SETTINGS' button. This will direct you to the device setting screen within the settings menu.

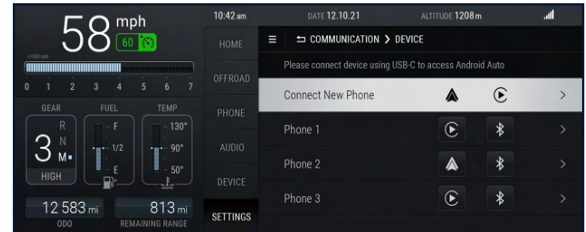

# MEDIA AND INFOTAINMENT

To connect a new phone, select 'Connect New Phone' on the infotainment screen. This will show a list of available phones. If there are multiple phones with the same name, the system will display the phone names with a number at the end.

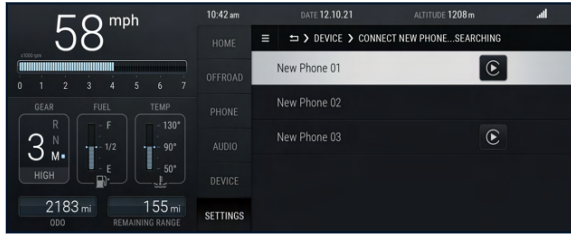

Once a phone is selected, a security pairing PIN will be visible on the infotainment screen.

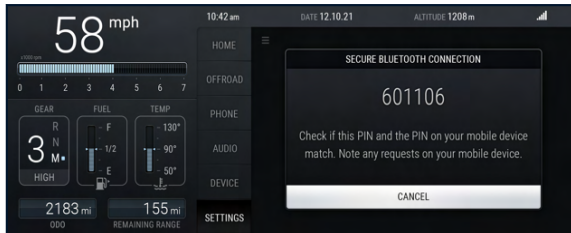

This pin will need to be entered into the phone you are trying to connect. If the PIN is entered incorrectly the connection will fail.

When the user clicks on the Bluetooth symbol during an active Apple CarPlay or Android Auto session, projection mode will be disabled and the mobile will be connected for native audio and phone.

## Sub Menu

When a phone has been connected and the user is inside the 'PHONE' tab, five sub menus will appear on the infotainment screen.

## Favourites

The 'FAVOURITES' menu will show a list of all the saved favourite phone contacts. It will display the image, name and phone number of each favourite.

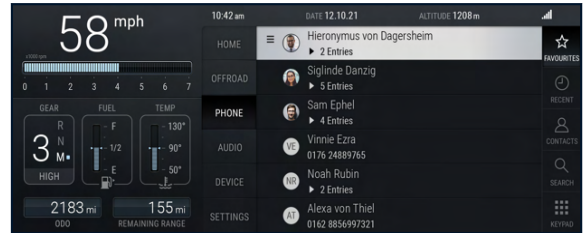

# MEDIA AND INFOTAINMENT

## Recent

The 'RECENT' menu, will show a list of the call history. The contact image, name and number will be visible, along with the time of call and type of call.

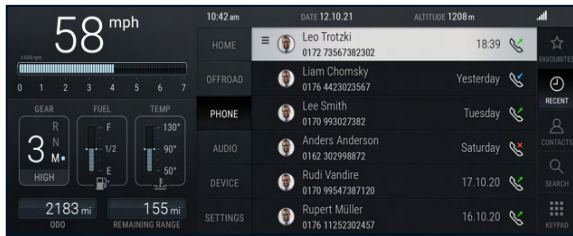

If a call was dialed, received or not received within the current day, then the time of the call will be visible. Calls from the previous day will be shown as 'Yesterday'. Calls up to a week before the current day will be shown as the specific day, such as, 'Tuesday'. Any call type over a week old will be shown as a date of when the call was dialed, received or not received.

## Contacts

The Contacts menu shows the synchronized contacts of the connected phone. The contact name and phone number of the contact will be visible including an image set for the contact.

If no name for a contact is available then the name will be left blank. If the contact selected has more than one phone number assigned

to it, then in the place of the phone number will be an arrow followed by the number of phone numbers assigned to that contact. Select the contact to reveal the entries assigned to the contact. There is a maximum of five phone numbers per contact.

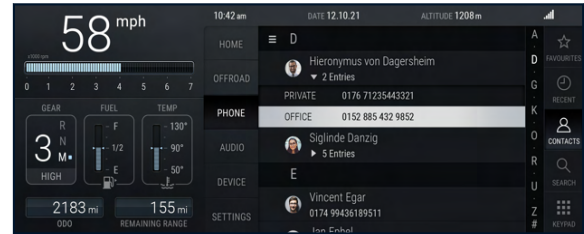

There is an alphabet bar to allow for faster navigation through the contact list. When using this bar, a floating cursor (D in the image) will appear and indicate the currently selected letter. This cursor is shown for two seconds. If there are no contacts associated with the



# MEDIA AND INFOTAINMENT

letter chosen, then the floating cursor will jump to the next available letter with contacts.

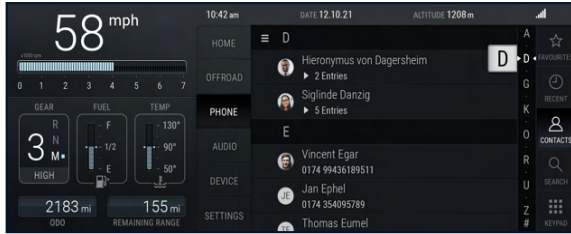

## Search

The user can search for available contacts by typing in their names. The keyboard will pop up automatically, here the user starts to type the name of the contact they want to search. The contacts will appear according to the input by the user. If there is no result, then the screen will display a message stating 'No Result'. If there is no input by the user, then all contacts will be shown.

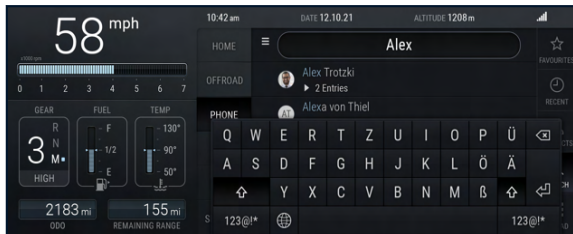

## Keypad

The user can use the keypad menu to search available contacts by number or to dial a number that is not already saved. If no call is made and no search results are recognised from the number entered, then the screen will display 'No Results List'.

The call button will be disabled if the input box is left empty by the user. Once a number has been entered the call button will become available.

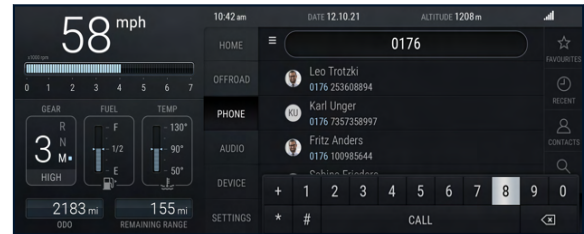

## Incoming Call

When a call is incoming, the call details will be displayed on the infotainment screen.

# MEDIA AND INFOTAINMENT

By default the cursor will be on the 'ACCEPT' button.

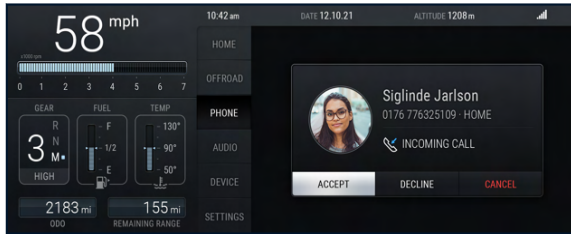

There will be three buttons visible when a incoming call screen is displayed.

BUTTON	DEFINITION
ACCEPT	Accepts the call.
DECLINE	Declines the call.
CANCEL	Dismisses the dialogue window and switches back to the previous screen.

## Dialling Call

When a call is dialled, the call details will be displayed on the infotainment screen.

While the call is dialling, there will be four buttons visible.

BUTTON	DEFINITION
CANCEL	Dismisses the dialogue window and returns to the previous screen.
MUTE	Mutes the microphone in the vehicle, and the button changes to "UNMUTE."
KEYPAD	Opens the number key pad.
ADD CALL	Placing the current call on hold opens the contact list with available submenu options. Initiating a new call will end the current call on hold.

## Active Call

When a call is answered and becomes active, the screen will display the caller's contact details along with a timer indicating the duration of the call.

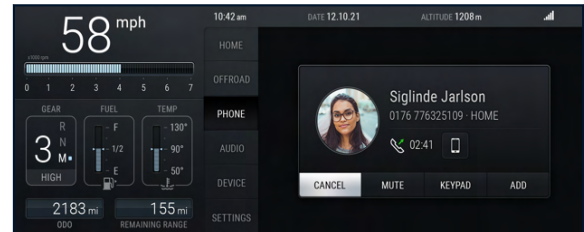

## MEDIA AND INFOTAINMENT

BUTTON	DEFINITION
CANCEL	Dismisses the dialogue window and switches back to the previous screen.
MUTE	Mutes the microphone in the vehicle and the button changes to 'UNMUTE'.
KEYPAD	Opens the number key pad.
ADD CALL	Current call is placed on hold, contact list opens with the sub menu options available. If the user starts a new call, the current call on hold ends.

### Header Call Bar

If the user switches from the call window, a call info bar will appear at the top of the infotainment screen. The content of the info call bar varies depending on the calls status. If the user is calling a contact

and switches to another screen, the following info call bar will be displayed:

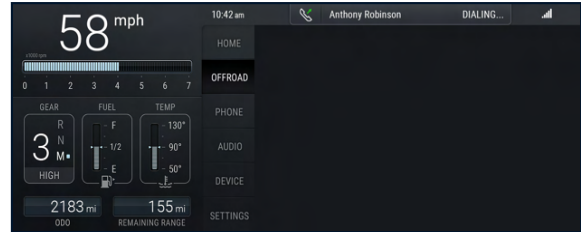

To recover the call window, the user can either touch the call section in the info bar or use the option menu and select the "Recover Call Dialogue" option.

### DEVICE

The 'DEVICE' menu will show devices that have been previously paired and stored. If the connected device supports Android Auto or Apple CarPlay, then the 'DEVICE' menu will become the default location to operate the associated features.

### CONNECTING PHONE DEVICE

If no phones are connected, the user can click on the device button and the settings page will appear directly.

## MEDIA AND INFOTAINMENT

To connect a new Phone, select 'Connect New Phone'. This will start the Bluetooth discovering mode and will show a list of available phones.

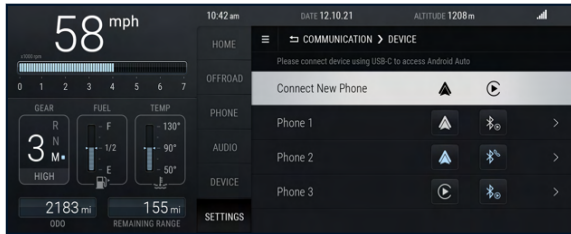

Once a phone is selected, a security pairing PIN will appear on the infotainment screen. Match the security PIN on your phone to confirm connection.

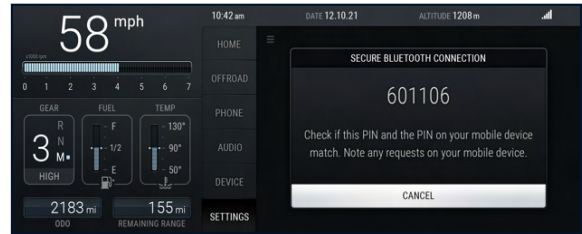

*NOTE: If there are multiple devices with the same name, the system will display the name assigned with a number at the end. For example, If there are two phones connected, both called Sam's Phone, then they will be displayed as Sam's Phone and Sam's Phone-1.*

### CONNECTING APPLE CARPLAY



*NOTE: Apple CarPlay requires IOS 13 and above to be compatible. IOS 12 and below may result in compatibility errors.*



*NOTE: Hotspot should be set to on, for wireless Apple CarPlay to work.*

After connecting the phone using Bluetooth, Apple CarPlay will be displayed automatically. If the phone is being connected for the first time, there will be an intermediate screen asking the user to agree to the privacy policy.

# MEDIA AND INFOTAINMENT

If the connection fails, a message will be shown on the infotainment screen.

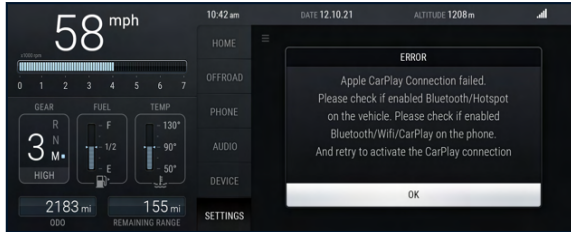

If a device connected to the infotainment system supports wireless Apple CarPlay, then you will be asked to connect once the phone device has been paired.

If there is already a wireless Apple CarPlay / Android Auto connection at the time of connecting a new device, a prompt will show on the screen, from which you can switch to the newly connected device.

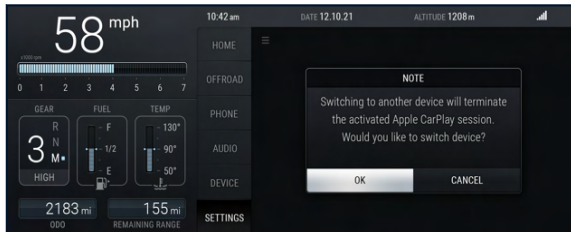

## CONNECTING ANDROID AUTO

To connect your device and access Android Auto, follow this procedure:

1. Connect the device using a Bluetooth connection.
2. A pop up message will be displayed on the infotainment screen, asking the driver to 'stop the car and follow instruction on your phone'.

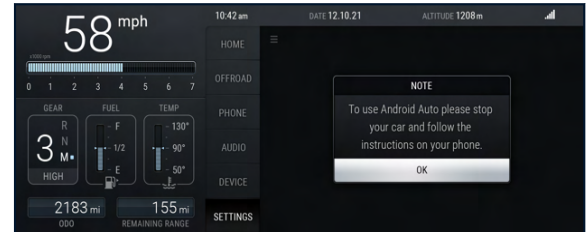

3. A message will pop up on the phone device, instructing the user on how to connect.
4. Once the instructions have been followed and completed on the phone device, press 'OK' on the infotainment screen.
5. If the connection has failed, then press the 'OK' button on the infotainment screen and start again from the beginning of the procedure.

## MEDIA AND INFOTAINMENT

6. The 'DEVICE' menu tab will now change to the Android Auto symbol, confirming the connection.

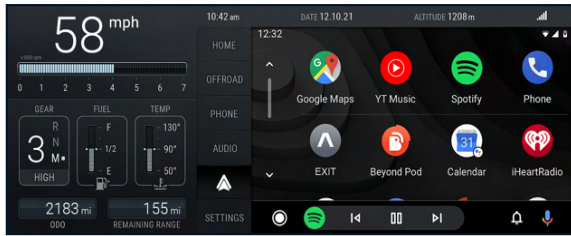

you can navigate through other audio source's using the lined indicators on the edge of the screen.



The audio sources are:

### AUDIO

When the audio tab menu is selected, Apple CarPlay connected by wireless connection, will always be shown on the screen. However,

MENU LEVEL	AUDIO SOURCE	DEFINITION
1	Apple CarPlay / Android Auto	Apple CarPlay / Android Auto will be shown as priority, if connected using a wireless connection.
2	Radio	Radio - AM/FM and DAB .
3	USB	USB connected devices.
4	Bluetooth	Devices connected using Bluetooth such as a phone or tablet.

# MEDIA AND INFOTAINMENT

## Audio Options Menu

Press the options menu to view and select:

1. Source (Radio waveband)
2. Auto seek all stations
3. Delete current station
4. Add to favourites
5. Traffic announcements

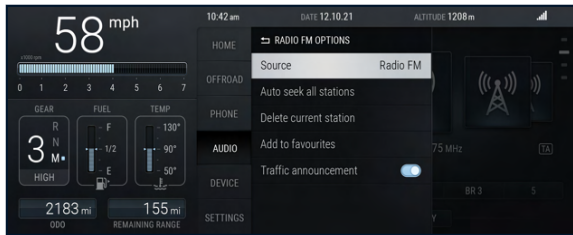

If the radio is set on DAB , then 'Add to favourites' will not be selectable.

Traffic announcements on and off button will be available in the radio options list if set on the 'FM' screen at the time of selecting the radio options button. Traffic announcements will be active by default.

OPTION MENU LIST	DEFINITION
Source	Pressing the source button in the option menu, will give you a list of frequency options.
Auto seek all stations	This will add all found stations to a preset radio list (not favourites). The first station found will start playing.
Delete current station	Press to delete the current station from the preset radio list.
Add to favourites	Add station to the favourites or remove from favourites if already saved.
Traffic Announcements	Press to switch off or on the traffic announcements.

## Tuner

# MEDIA AND INFOTAINMENT

## FM/AM



DISPLAY FOCUS	DEFINITION
Station list	Display available FM/AM stations.
Current frequency	Currently selected frequency.
Five favourite frequencies	Saves up to five frequencies to the favourites by long pressing the frequency. Short press frequency to start playing the station.
Frequency button	Pop-up dialogue to search previous or next station.

To switch from one focus to another, use either the rotary controls or the touch screen. Move the rotary knob up or down and the focus will switch between the station list, current station, favourites and the frequency button.

When the 'FREQUENCY' button is pressed, a pop-up dialogue will appear to change the frequency. The frequency can be changed in this dialogue box by either using the touch screen or the rotary controls. Once the correct frequency has been found, press the 'OK' button to close the dialogue.

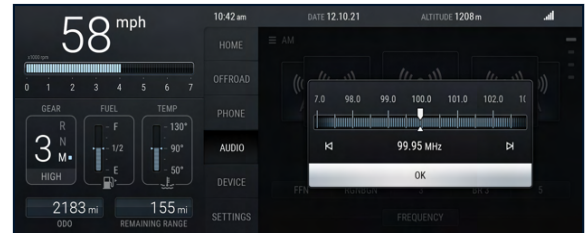

## DAB

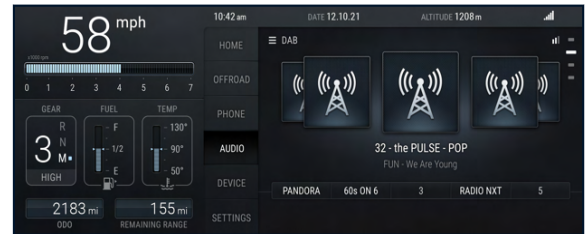



## MEDIA AND INFOTAINMENT

DISPLAY FOCUS	DEFINITION
Station list	Display available DAB stations.
Current frequency	Currently selected Station.
Five favourite stations	Saves up to five stations to the favourites by long pressing on the station. Short press the station to start playing.

### USB

When a USB device is connected, the screen displays artist or cover information if available; otherwise, a default image is shown.

While scrolling through cover images while a track is playing, the information of the currently playing song will appear above the cover images.

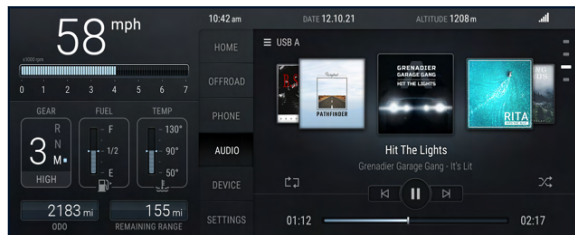

On the screen, choose repeat, shuffle, play, pause, stop, or adjust the track time bar. Scroll through the playlist and cover info using the rotary knob or infotainment screen. Press the back button to restart the current track from the start.

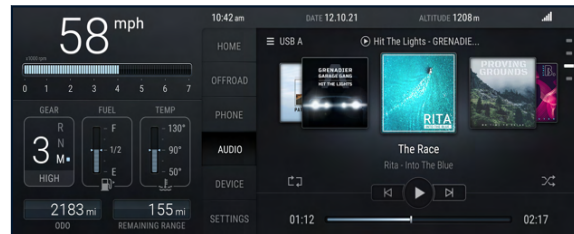

When focusing on the time bar at the bottom of the screen, rotate the rotary knob to move forwards and backwards along the bar. Press the rotary knob inwards to start playing or pause the track. This can also be done using the infotainment screen.



**NOTE:** Use the infotainment screen to activate the play, pause, skip, repeat, and shuffle buttons. The rotary controller cannot activate these quick touch buttons. Access the USB options menu to adjust repeat and shuffle using the rotary controller.

### USB Options

When a USB is connected and the user is in the 'AUDIO' tab menu, press the options menu to view USB options.

# MEDIA AND INFOTAINMENT

In the USB options menu, you can select the following options:

USB OPTIONS	DEFINITION
Input	Select between available USB devices
Shuffle	Set shuffle to active or inactive
Repeat	Switch between repeating all playlist songs or a single track.

**i** *NOTE: Shuffle and repeat are not available for Android Auto. For Apple CarPlay, shuffle and repeat are controlled within the app itself.*

Choose 'Input' to navigate through available USB devices. Once a device is selected, you can manage content and choose to play either the complete USB or any sub folders created.

## Bluetooth

When a Bluetooth device is connected, the infotainment screen displays information about the currently selected track to play, if available. Otherwise, a default image is shown.

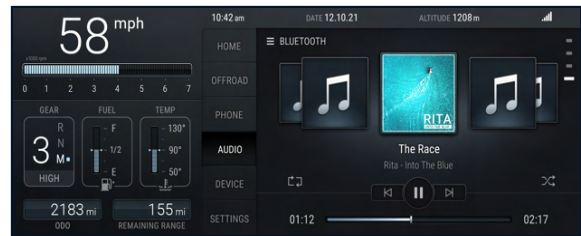

**i** *NOTE: Track information displayed is solely dependent on the connected Bluetooth device.*

You can select repeat, shuffle, play, pause, stop, or adjust the track time bar on the infotainment screen.

When focused on the time bar at the bottom of the screen, rotate the rotary knob to move forwards and backwards along the bar. Press the rotary knob inwards to start playing or pause the track. This can also be done using the infotainment screen.

**i** *NOTE: The repeat and shuffle buttons are only activated via the infotainment screen; the rotary controls cannot activate these quick touch buttons. Access the Bluetooth*

# MEDIA AND INFOTAINMENT

*options menu to adjust repeat and shuffle using the rotary controls.*

## Bluetooth Options

When a Bluetooth device is connected and the user is inside the 'AUDIO' tab menu, press the options menu to see the Bluetooth options.

Inside the Bluetooth options menu, you will be able to select the following options:

OPTIONS	DEFINITION
Input	Select between available connected devices
Shuffle	Set shuffle to active or inactive
Repeat	Switch between repeating all songs in the playlist or repeating a single track.

GENERAL SETTINGS	DEFINITION
Language	Opens the language selection window, here the user can select the preferred language.
Unit	Opens the unit menu, allowing the user to set preferred visual units for Speed, Fuel, Pressure, Distance, and Temperature, such as °C or °F.
Time / Date	Users can set the time and date to automatic, adjust the format, select the time zone, and enable or disable daylight saving time.

## SETTINGS

Navigate the settings menu by either the touchscreen or the rotary controller.

The settings menu has the following selectable options:

- > General.
- > Display Settings.
- > Vehicle Functions.
- > Acoustic Settings.
- > Communication.
- > Pathfinder File Transfer.

### General

## MEDIA AND INFOTAINMENT

---

GENERAL SETTINGS	DEFINITION
Rotation direction of CCI	Change the rotational direction of the rotary controller. For instance, switch from clockwise to anti-clockwise rotation.
Order of Contact Name	Choose to display contact names as "surname forename" or "forename surname".
CCI Favourites	Users can assign the favourite button's function to instantly call a registered contact without confirmation.
Reset General Settings	Reset general settings to default values, with confirmation prompt.
Reset All	Reset all settings to default values.

### Display Settings

The 'DISPLAY' menu consists of the following options:

DISPLAY SETTINGS	DEFINITION
Display Brightness	Adjust the infotainment screen brightness.
Configure Info Areas	Configure information, such as, Average Fuel, Average Speed, Battery Charge, Trip Distance, Outside Temperature, Audio Source, Date, Travel Time, and Odometer.
Reset Display Settings	Reset all display settings to default values.

### Vehicle Functions

The 'VEHICLE FUNCTIONS' menu consists of the following options:

## MEDIA AND INFOTAINMENT

---

VEHICLE FUNCTIONS	DEFINITION
Instrument Illumination	Adjust the brightness of the illuminated instruments.
Central Locking System	Adjust Central Locking System settings, such as, Drive away locking, Remote Lock Feedback, Auto Door Unlock, Follow Me Home.
Park Distance Control - Front Deactivation	Here, the front PDC can be deactivated, turning off the four front sensors.
Vehicle Information	View information, such as, Engine Oil levels and temperatures, AdBlue levels (if applicable), Tyre Pressure, Battery status and Active Warning Messages.
Speed Warning Sound	An acoustic warning sound will activate when the vehicle reaches the set speed.
Passenger Airbag	Switch on or off the Passenger Airbag.
Trip Information	Trip values for TRIP A and TRIP B. Reset individually.
Reset Vehicle Function Settings	Reset all vehicle function settings to default.

### Acoustic Settings

The 'ACOUSTIC SETTINGS' menu consists of the following options:

ACOUSTIC SETTINGS	DEFINITION
Equalizer	Set the Equalizer settings to the preferred frequency.
Fader / Balance	The Fader / Balance (if applicable) can be chosen for the speaker outputs within the vehicle.
Volume Settings	Here, users can customise volume settings, including volume at Vehicle Start, Volume Minimization, Speed Dependent Volume Control, and Notification Volume.

## MEDIA AND INFOTAINMENT

---

ACOUSTIC SETTINGS	DEFINITION
PDC Sound	Adjust the PDC sound volume within a range of 0-14.
Input Sound	Adjust the input sound volume within a range of 0-14.
Warning Sounds	Set Warning Sounds to Low, Middle, or High volume.
Reset Acoustic Settings	Reset all acoustic settings to default values.

### Communication

The 'COMMUNICATON' menu consists of the following options:

COMMUNICATION SETTINGS	DEFINITION
Device List	Connect a new device or check the connection status of devices.
Bluetooth	Access the Bluetooth menu to toggle Bluetooth on or off, enable or disable Bluetooth visibility, and change the Bluetooth device name.
WiFi Hotspot Active and Visible	Toggle WiFi Hotspot on or off and view settings (Phone projections only).
Reset Communication Settings	Reset all communication settings to default values.

# MEDIA AND INFOTAINMENT

## Pathfinder File Transfer

The 'PATHFINDER FILE TRANSFER' menu consists of the following options:

- > USB A
- > USB C

> Hard Disk Drive (HDD)

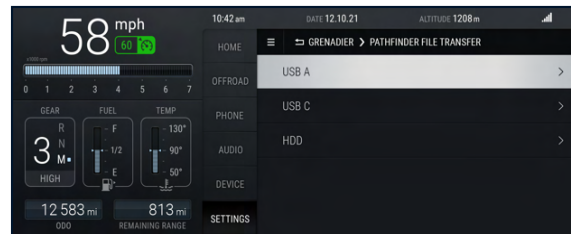

SETTINGS	DEFINITION
USB A	Users have access to the GPX Collection Folder, where they can view all saved GPX Files on the USB device. GPX files can be imported individually or all at once, while GPX Collection Folders can be imported one by one, all at once, or as a complete folder.
USB C	Users can access the GPX Collection Folder to view and import GPX files from a USB device. They can import files individually or all at once, and import entire GPX Collection Folders either individually or all together.
HDD	Here, the user can view the GPX Collection Folder and any saved GPX Files. GPX Collection Folders and GPX files, can be exported, deleted or renamed.

# MEDIA AND INFOTAINMENT

Below is an example of the USB, GPX Files and GPX Collection Folder options:

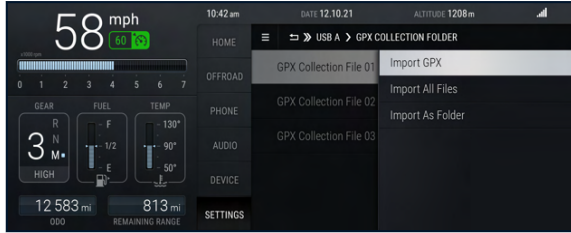

Below is an example of the HDD, GPX Files and GPX Collection Folder options:

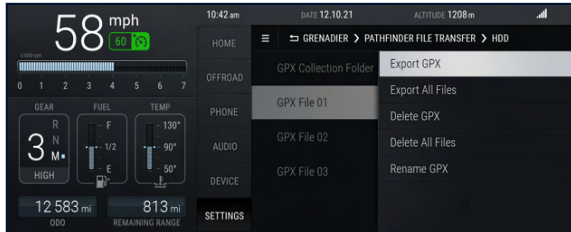

## AUDIO OUTPUT SPECIFICATION

There are four speakers inside the vehicle, one located inside each door of the vehicle.

The minimum audio speaker output specification is 4x25 Watt true Root Mean Square (RMS). The speakers are rated individually at 4ohm each delivering high quality sound for long periods of time.

## CONNECTIVITY

### Front Data-In USB Ports

The front data-in USB Ports, are located inside the Central Stowage Tray or the optional Central Stowage Box, Lockable, and identified by the  symbol on the cap cover.

There are two types of USB port, one type A and one type C port. Both USB ports transfer data with the USB 2.0 protocol and data connection to the head unit and provide power according to the BC 1.2 charging standard to the connected USB device.

### Auxiliary Charge Points (OPTIONAL)

Additional charging points for all of your devices. This option provides one USB-A and one USB-C port for the rear passengers, and a 12V socket in the loadspace.

The USB charging points are identified by the  symbol on the cap cover.



## MEDIA AND INFOTAINMENT

---

The USB A port provides a 2,4A charging current and the USB-C port provides a 3A charging current.

The USB A and C are covered by a cap to ensure they are IP54 compliant.

The cap will latch when closed to ensure sealing compression to give feedback when the cap is closed.

# CLIMATE CONTROL

---

CENTRE CONSOLE CLIMATE CONTROLS .....	171
HEATED FRONT SEATS (OPTIONAL) .....	171
FAN SPEED SETTING .....	172
TEMPERATURE AND AUTO SETTING .....	172
AIR FLOW ZONES .....	172
RECIRCULATION .....	172
AIR CONDITIONING .....	172
WINDOW DEMIST REAR .....	172
WINDOW DEMIST FRONT .....	173
VENT ADJUSTMENT .....	173

# CLIMATE CONTROL

## CENTRE CONSOLE CLIMATE CONTROLS



**WARNING:** If the cab of the vehicle smells of Volatile Organic Compounds (VOCs) within a few months of purchase, thoroughly ventilate the cab of the vehicle. This must be done even if there are no occupants in the vehicle.



**WARNING:** If the temperature rises when the vehicle is stationary, for example, when the vehicle is in the sunshine. Then it is recommended that all the windows are opened and the air circulation mode is switched off. This is to allow fresh air into the vehicle.

The Climate Control buttons are numbered within the text in this section. Where there is a number in brackets, refer to this Centre Console image.

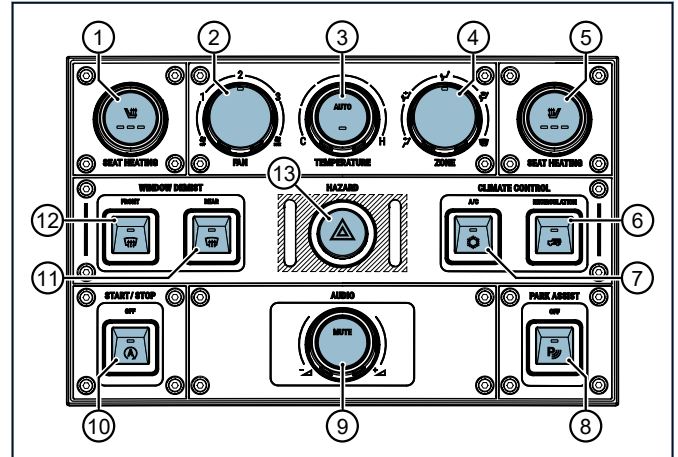

## HEATED FRONT SEATS (OPTIONAL)



**WARNING:** Do not re-activate the heated seats directly after the auto timer has switched off the heated seats. Re-activating the heated seats repeatedly can cause the seat to become very hot, and can cause burn injuries to persons with limited sensitivity to temperature changes.

# CLIMATE CONTROL

---



**CAUTION:** To reduce the risk of damage to the seat heating elements, do not kneel on the seats. Kneeling on the seats may damage the heating elements.



**CAUTION:** Do not place any heavy items on the seats, pressure on one area of the seat can result in damage to the heating elements.

Independently controlled heated front seats with three temperature settings for both the driver and passenger.

Press either or both buttons (1) and (5) on the centre console, to cycle the seat heating level on the front seats. The LEDs show which heating level is set, where the higher the number of LEDs illuminated, the greater the heating level.

## FAN SPEED SETTING

Rotate the fan speed knob (2), on the centre console, clockwise to increase the fan speed and anti-clockwise to decrease the fan speed.

## TEMPERATURE AND AUTO SETTING

Rotate the temperature knob (3), on the centre console, clockwise to increase the temperature and anti-clockwise to decrease the temperature.

Press the auto button once, to switch on the auto setting. The vehicle will maintain the same temperature by automatically increasing and decreasing the temperature of the air coming through the air vents.

## AIR FLOW ZONES

Rotate the air flow zone knob (4), on the centre console, to select the preferred air vents to distribute air flow into the vehicle.

## RECIRCULATION

Press button (6) on the centre console, to recirculate the air inside the vehicle.

## AIR CONDITIONING

Press button (7) on the centre console, to switch on the air conditioning. This will activate the air conditioning to distribute cold air inside the vehicle.

## WINDOW DEMIST REAR

Press button (11) on the centre console, to switch on the window demist rear feature. This will demist the rear window for clear visibility. Press a second time to switch off the window demist rear.

# CLIMATE CONTROL

---

## **WINDOW DEMIST FRONT**

Press button (12) on the centre console, to switch on the window demist front feature. This will demist the front window for clear visibility. Press a second time to switch off the window demist front.

## **VENT ADJUSTMENT**

Adjust air vents using the vent knob. Push up/down to adjust blade direction, left/right to change vent angle, and rotate to open/close.

## MAINTENANCE AND TECHNICAL INFORMATION

---

CAPACITIES AND TECHNICAL INFORMATION .....	175
SERVICE AND MAINTENANCE .....	181
FUEL .....	193
ELECTRICAL SYSTEMS .....	196
EXTERIOR CARE .....	209
INTERIOR CARE .....	213
HOSING THE INTERIOR .....	215
WHEELS AND TYRES .....	222
CUSTOMER INFORMATION .....	230

# MAINTENANCE AND TECHNICAL INFORMATION

## CAPACITIES AND TECHNICAL INFORMATION

### Mass and Load



**WARNING:** Do not load the vehicle beyond its intended capacities, loading equipment on the roof may change the vehicle's handling characteristics.

MASS & LOAD	UTILITY 2-SEATER		UTILITY 5-SEATER		STATION WAGON	
	PETROL	DIESEL	PETROL	DIESEL	PETROL	DIESEL
Gross vehicle weight [kg]	3500	3500	3500	3500	3500	3500
Unladen weight (without driver) [kg]	2 629	2 704	2 665	2 740	2741 <sup>T</sup> - 2678 <sup>F</sup>	2816 <sup>T</sup> - 2753 <sup>F</sup>
Maximum payload (without driver) [kg]	871	796	835	760	759 <sup>T</sup> - 822 <sup>F</sup>	684 <sup>T</sup> - 747 <sup>F</sup>
Dynamic roof load (with roof rack) <sup>R</sup> [kg]	150	150	150	150	150	150
Static roof load (with roof rack) <sup>R</sup> [kg]	420	420	420	420	420	420
Maximum unbraked trailer mass (on-road) [kg]	750	750	750	750	750	750
Maximum braked trailer mass (on-road) [kg]	3500	3500	3500	3500	3500	3500

## MAINTENANCE AND TECHNICAL INFORMATION

MASS & LOAD	UTILITY 2-SEATER		UTILITY 5-SEATER		STATION WAGON	
	PETROL	DIESEL	PETROL	DIESEL	PETROL	DIESEL
Maximum Trailer Nose Weight [kg]	350*	350*	350*	350*	350*	350*
Gross train weight [kg]	7000	7000	7000	7000	7000	7000

<sup>R</sup> With Full Length Roof Rack (Roof Rack weight not included).

MASS & LOAD	QUARTERMASTER	
	PETROL	DIESEL
Gross vehicle weight [kg]	3500	3500
Unladen weight (without driver) [kg]	2665	2740
Maximum payload (without driver) [kg]	835	760
Dynamic roof load (with roof rack) <sup>R</sup> [kg]	120	120
Static roof load (with roof rack) <sup>R</sup> [kg]	375	375
Maximum unbraked trailer mass (on-road) [kg]	750	750

MASS & LOAD	QUARTERMASTER	
	PETROL	DIESEL
Maximum braked trailer mass (on-road) [kg]	3500	3500
Maximum Trailer Nose Weight [kg]	350*	350*
Gross train weight [kg]	7000	7000

<sup>R</sup> With Quartermaster Roof Rack (Roof Rack weight not included).

<sup>T</sup> Includes Trialmaster Edition specific options.

<sup>F</sup> Includes Fieldmaster Edition specific options.

\* Please refer to the plating on the vehicle for the maximum nose weight.



## MAINTENANCE AND TECHNICAL INFORMATION



*NOTE: The mass and load tables above, are not applicable to the Double Cab Chassis.*

### Volumes and Loadspace

VOLUME & LOADSPACE	UTILITY 2-SEATER		UTILITY 5-SEATER		STATION WAGON	
	PETROL	DIESEL	PETROL	DIESEL	PETROL	DIESEL
Maximum volume behind 1st row seat [Litre]	2088	2088	--	--	2035	2035
Maximum volume behind 2nd row seat [Litre]	--	--	1255	1255	1152	1152
Maximum luggage length behind 1st row seat [mm]	1512	1512	--	--	1645	1645
Maximum luggage length behind 2nd row seat [mm]	--	--	890	890	799	799
Floor length behind 1st row seat [mm]	1687	1687	--	--	1795	1795
Floor length behind 2nd row seat [mm]	--	--	1062	1062	983	983
Loadspace width (floor between wheel-arches) [mm]	1064	1064	1064	1064	1064	1064
Maximum loadspace width [mm]	1268	1268	1268	1268	1268	1268
Lift in height [mm]	899	899	899	899	899	899

## MAINTENANCE AND TECHNICAL INFORMATION

VOLUME & LOADSPACE	UTILITY 2-SEATER		UTILITY 5-SEATER		STATION WAGON	
	PETROL	DIESEL	PETROL	DIESEL	PETROL	DIESEL
Loadspace height [mm]	1047	1047	1047	1047	1047	1047

VOLUME & LOADSPACE	QUARTERMASTER	
	PETROL	DIESEL
Pick Up Box Floor length [mm]	1564	1564
Loadspace width (floor between wheel-arches) [mm]	1137	1137
Maximum loadspace width [mm]	1619	1619

VOLUME & LOADSPACE	QUARTERMASTER	
	PETROL	DIESEL
Lift in height [mm]	906	906
Pick Up Box height [mm]	485	485



*NOTE: The volume and loadspace tables above, are not applicable to the Double Cab Chassis.*

### Vehicle Dimensions

DIMENSIONS	UTILITY 2-SEATER		UTILITY 5-SEATER		STATION WAGON	
	PETROL	DIESEL	PETROL	DIESEL	PETROL	DIESEL
Length (without spare wheel) [mm]	4683	4683	4683	4683	4683	4683
Length (including spare wheel) [mm]	4895	4895	4895	4895	4895	4895

## MAINTENANCE AND TECHNICAL INFORMATION

DIMENSIONS	UTILITY 2-SEATER		UTILITY 5-SEATER		STATION WAGON	
	PETROL	DIESEL	PETROL	DIESEL	PETROL	DIESEL
Width with mirrors [mm]	2146	2146	2146	2146	2146	2146
Width with mirrors folded [mm]	1930	1930	1930	1930	1930	1930
Height (kerb weight) [mm]	2050	2050	2050	2050	2050	2050
Track Width [mm]	1645	1645	1645	1645	1645	1645
Front Overhang [mm]	887	887	887	887	887	887
Rear Overhang [mm]	874	874	874	874	874	874
Wheelbase [mm]	2922	2922	2922	2922	2922	2922
Approach Angle (kerb weight) [°]	35.5	35.5	35.5	35.5	35.5	35.5
Ramp Breakover Angle (kerb weight) [°]	28.2	28.2	28.2	28.2	28.2	28.2
Departure Angle (kerb weight) [°]	36.1	36.1	36.1	36.1	36.1	36.1
Ground Clearance (kerb weight) [mm]	264	264	264	264	264	264
Wading Depth [mm]	800	800	800	800	800	800

## MAINTENANCE AND TECHNICAL INFORMATION

DIMENSIONS	UTILITY 2-SEATER		UTILITY 5-SEATER		STATION WAGON	
	PETROL	DIESEL	PETROL	DIESEL	PETROL	DIESEL
Wading Entrance Angle [°]	16	16	16	16	16	16
Wading Departure Angle [°]	16	16	16	16	16	16

QUARTERMASTER		
DIMENSIONS	PETROL	DIESEL
Length (without spare wheel) [mm]	5440	5440
Length (including spare wheel) [mm]	5440	5440
Width with mirrors [mm]	2146	2146
Width with mirrors folded [mm]	1943	1943
Height (kerb weight) [mm]	2019	2019
Track Width [mm]	1645	1645
Front Overhang [mm]	887	887
Rear Overhang [mm]	1328	1328
Wheelbase [mm]	3227	3227

QUARTERMASTER		
DIMENSIONS	PETROL	DIESEL
Approach Angle (kerb weight) [°]	35.5	35.5
Ramp Breakover Angle (kerb weight) [°]	26.2	26.2
Departure Angle (kerb weight) [°]	22.6	22.6
Ground Clearance (kerb weight) [mm]	264	264
Wading Depth [mm]	800	800
Wading Entrance Angle [°]	16	16
Wading Departure Angle [°]	16	16

# MAINTENANCE AND TECHNICAL INFORMATION



*NOTE: The dimension tables above, are not applicable to the Double Cab Chassis.*

## Quartermaster Tailgate



**CAUTION:** Do not use the fixation points at the bottom of the tailgate. There is a protective coating to protect the fixing points from corrosion. If a screw and/or fixing is installed and/or removed, then the surface protection will be removed and corrosion may begin. The same applies when removing the Standard Loadbay eyes to use the Accessory Utility Rail.



**CAUTION:** The maximum static load for the Quartermaster tailgate is 225 kg (496 lbs).

\*Not applicable to the Double Cab Chassis

## SERVICE AND MAINTENANCE

### General Information

Various systems on this vehicle are very sophisticated and complex, there is specialised equipment necessary to carry out service and maintenance on these vehicle systems, therefore owner maintenance should be restricted to the routine procedures described in this section.

Any servicing beyond what is described in this section should be carried out at the regular interval points by an INEOS approved partner. Any maintenance that is not described in this section will need to be carried out by an INEOS approved partner. If there is a malfunction with any of the systems included in this section, it is advised the vehicle is professionally inspected and repaired by an INEOS approved partner.

### QR Code

It is important to keep the vehicle serviced and maintained. Follow the schedule provided to ensure the vehicle will run reliably, smoothly and efficiently. To see the service schedule, please scan the QR code below:



### Parts and Lubricants

When servicing the vehicle, it is essential that only the recommended parts and correct fluid specifications are used. This will ensure the longevity of the vehicle's life and performance.

## MAINTENANCE AND TECHNICAL INFORMATION



**WARNING:** Operating materials, for instance oils, greases, coolants, fuels, can contain harmful ingredients. There is a risk of injuries or danger to life. Follow the instructions on the containers. Avoid the contact of articles of clothing, skin or eyes with operating materials. Do not refill operating materials into different bottles. Store operating materials out of reach of children.



**CAUTION:** If oils and lubricants used do not meet the minimum guideline specifications, the vehicle may show signs of excessive wear and will require maintenance, if the damage caused is not detrimental. It is important that the correct oils and lubricants are used to avoid build up of deposits as this can cause considerable harm and damage to the environment with increased pollution.



**CAUTION:** If it evident to INEOS that the use of non-approved parts or products has caused damage to the vehicle or engine, then INEOS may refuse to authorise the repair of any damages arising from the use of those products under the terms of the manufacturers warranty.

### Fuel System



**WARNING:** Do not allow the fuel levels in the fuel tank to reach empty. This will starve the engine of fuel and may damage the fuel system, e.g. the fuel pump(s).



**WARNING:** Modifications or additions to the fuel system, unless designed by INEOS, is prohibited. Be aware that any modifications or additions installed may be dangerous and can cause significant damage to the fuel system. All Service Action and Safety Recall Actions must be undertaken by an INEOS approved partner.

The Vehicle uses a complex and specialist electronic fuel injection system to give maximum reliability and performance with safe vehicle emissions. For these reasons, it is essential that the owner trusts the INEOS service team to carry out regular servicing and maintenance, at the required intervals or at a point of any malfunction.

### Restraint System

INEOS recommend that the inflatable restraint systems (airbags) and seat belt components installed to this vehicle are replaced at ten year intervals from the date of manufacture on the certification label.

### Servicing and Maintenance Safety Precautions

It is important, when carrying out any servicing tasks or maintenance tasks, that the following safety precautions are observed and followed:





**WARNING:** When the vehicle is lifted with a lifting jack, do not work beneath or place objects under the vehicle, unless it is correctly supported by equipment designed to safely hold the vehicle in the air.

## MAINTENANCE AND TECHNICAL INFORMATION

---

 **WARNING:** Always wear protective clothing and equipment where possible to ensure your own protection from dangerous or corrosive substances.

 **WARNING:** There are many moving parts that can cause harm. The cooling fan may still operate when the engine is not operating. Keep hair, hands, clothing and any other items such as jewellery and tooling clear of moving parts, such as, drive belts, pulleys and any other operating mechanisms. It is recommended that any clothing or jewellery that might cause harm when trapped or exposed to heat, such as, necklaces, rings, bracelets or ties and loose clothing should be removed before working on the vehicle.

 **WARNING:** When possible, work should be carried out when the engine is cold and at suitable temperature underneath. Catalytic converters, DPFs and GPFs radiate high temperatures, even after the engine and ignition has been switched off.

 **WARNING:** Avoid skin contact with hot components such as the engine and exhaust system. It is paramount that skin contact is avoided when there are engine fluids or steam escaping areas of the vehicle. This indicates a malfunction and can cause fluids and steam to be unpredictable, hot and harmful.

 **WARNING:** There are flammable and toxic substances in and around the vehicle engine bay, including underneath the vehicle. Flammable and toxic substances can be

fluids or fumes in the air. For example, petrol is a highly flammable fluid that releases fumes into the air. Petrol fumes in a confined space can be highly explosive.

 **WARNING:** In the event of a substance spillage, such as, petrol, switch the engine off. Do not use a flame or spark near fuel or fuel vapours. Do not smoke near fuel or fuel vapours.

 **WARNING:** Ensure the area is well ventilated when the engine is operating. Harmful fumes will be produced. Fumes and vapours can be colourless and odourless, causing unconsciousness and contributing to death.

 **WARNING:** Keep children and pets clear of the vehicle when maintenance is undertaken. There should be no human, animal or any items inside the vehicle when maintenance is being carried out around or underneath the vehicle. Avoid added weight on the vehicle stands and any movement of the vehicle itself. Components and mechanisms unexpectedly moving can cause harm or death.

 **NOTE:** *Deviating from the prescribed INEOS service procedures or using non-approved parts could invalidate the warranty.*

# MAINTENANCE AND TECHNICAL INFORMATION

---

## Engine Oils and Disposal Warnings



**WARNING:** Keep out of reach of children.



**WARNING:** Prolonged and repeated contact with used engine oils can cause serious skin disorders, including dermatitis and cancer. Avoid excessive contact, wash thoroughly after contact.



**WARNING:** When the oil is changed, be sure that it is done by an experienced person. In addition, observe all laws regarding the disposal of waste oil and toxic fluids. It is illegal to pollute drains, water courses or soil with toxic chemicals, such as, used engine oil. Always dispose of vehicle liquids and lubricants at authorised waste disposal sites or at garage and refill stations. If in doubt, contact your local authorities for advice.

## Environment Protection



**WARNING:** It is illegal to pollute drains, water courses, or soil. Use authorised waste disposal facilities, including civic amenity sites and garages providing facilities for receipt of used oil. If in doubt, contact your local authority for advice.

## Dangerous Substances



**WARNING:** Keep out of reach of children. Some substances contain harmful chemicals and toxins, which can cause burning and blindness or even poisoning if consumed.



**WARNING:** Always adhere to the instructions accompanying any liquids, components, or substances, whether printed on labels or stamped on the components. These instructions are designed to safeguard your health and personal safety, and should never be disregarded.



**WARNING:** Ensure to avoid contact with hazardous substances commonly found in motor vehicles, such as battery electrolyte, antifreeze, oil, brake fluid, petrol, windscreen washer additives, lubricants, refrigerant, and adhesives. These substances can be poisonous or harmful to the skin, eyes, and mouth. It's crucial to wear protective clothing and equipment to minimize prolonged contact with these substances.

## Emission Control

Unauthorised replacement, modification, or tampering with emissions equipment in the vehicle may be illegal and subject to legal penalties. Engine settings must not be altered, as they are set to comply with strict exhaust emission regulations. Incorrect engine



## MAINTENANCE AND TECHNICAL INFORMATION

---

settings can impact emissions, engine performance, fuel consumption, and may damage components like the catalytic converter.

### Owner Maintenance Checks

INEOS recommends that the vehicle be serviced and maintained by an INEOS approved partner to optimise its lifespan and ensure safe operation. Regular checks between scheduled services, especially before operating in challenging terrain or weather conditions and embarking on long journeys, are also advised. Consult the following pages for guidance and check procedures.

#### Before operation Checks:

- > Walk around the vehicle to be sure there are no obstacles or objects, that could cause damage or obstruction to the vehicle.
- > Clear the windscreen and other windows of any obstructions, such as, frost for clear visibility.
- > It is also recommended, to visually check underside of the vehicle for signs of fluid leaks.
- > Check the tyres for signs of wear and deflation.
- > Check the operation of the lights, direction indicators, horn, washers and wipers.
- > Operation of seat belts and brakes.

- > Check there is a suitable amount of fuel to complete the intended journey or enough to get to a planned refuelling station.
- > Position mirrors for clear vision around the vehicle and through your rear view mirror.

#### Weekly Checks:

- > Tyre Condition, such as, tread depth, foreign objects, cuts, and or abrasions to the side wall
- > Coolant Level
- > Brake fluid level
- > Power steering fluid
- > Power Steering Fluid Level
- > Windscreen washer fluid level
- > Check operation of windscreen washers
- > Air Conditioning Operation

#### Engine Oil



**CAUTION: It is important to check the engine oil level regularly. Running the engine with low levels or high levels of engine oil, can cause serious engine damage.**

Check the engine oil level every fourth fuel tank fill or weekly, whichever is the sooner.

## MAINTENANCE AND TECHNICAL INFORMATION

Please see the 'Engine Oil Check and Refill' section for more information.

### Bonnet Release

To open the bonnet, pull the lever under the instrument panel to release the latch, then lift the bonnet to access the engine compartment.



*NOTE: Pull the bonnet opening lever twice to ensure the latches have released inside the engine bay, allowing you to open the bonnet manually.*

To open the bonnet, secure it in place with the bonnet stay, which can be positioned in two locations: one for normal access and the other for service access. When closing the bonnet, lower it until nearly closed, then let it fall shut. If the bonnet doesn't close properly, open it again and try closing it with light hand pressure.

### Washer Fluid level Check and Refill



**WARNING: Refill the washer fluid reservoir only when the engine is cool and switched off. Avoid refilling the screen wash reservoir when the engine is hot.**



**WARNING: Washer fluid can be highly concentrated and can be extremely flammable. It could ignite if it comes into contact with hot materials such as the exhaust manifold or the engine block.**



**WARNING: INEOS recommend that a suitable funnel is used to avoid spillage, however clean any spillage around the filler opening before starting the engine.**



**WARNING: In the event of a fire in the engine compartment, close the bonnet immediately if possible and call the fire service from a safe distance.**



*NOTE: The rear washer system, uses the same reservoir as the front washer system. The reservoir is located inside the engine bay, inside the front left hand side wing.*







Only use approved washer fluid to fill the reservoir to avoid damage to the washer fluid system and wiper blades. Using unapproved fluids can lead to damage and staining of paintwork and plastic trims. Dilute washer fluid according to instructions, especially in cold conditions to prevent freezing. Be aware of local regulations regarding VOC content in washer fluid and ensure it provides adequate freeze resistance for all climates where the vehicle will be used.

To fill the washer fluid:

1. Remove the washer reservoir cap.
2. Position a clean suitable funnel into place.
3. Add the washer fluid.
4. Wipe any spillage.
5. Replace the cap until secure.

## MAINTENANCE AND TECHNICAL INFORMATION

### Engine Oil Check and Refill

-  **WARNING:** Engine oil or components, may be hot and could cause severe burns. Make sure the oil and components are given time to cool down before handling.
-  **WARNING:** Do not remove the oil filler cap when the engine is running. Hot oil will burn and cause harm.
-  **CAUTION:** Running the engine with low levels or high levels of oil can cause serious engine damage.
-  **CAUTION:** Failure to use engine oil that meets the required specification can result in a build up of sludge and deposits. This may lead to engine failure.
-  **CAUTION:** Using engine oil that is thicker than the recommended specification can add load onto the engine, subsequently reducing the vehicles overall fuel efficiency.
-  **CAUTION:** This vehicle's warranty may be invalidated, if damage is caused by the use of incorrect engine oil. Low quality or obsolete oils, do not give the protection required by modern engines.



**CAUTION:** Operating materials are hazardous and could be poisonous. Handle with care. Pay attention to information given on the containers.



**CAUTION:** The levels should only be between minimum and maximum never over maximum or under minimum. Contact an INEOS approved partner, if the oil level is below minimum or above maximum between services intervals.



**CAUTION:** Oil additives can damage the engine. There is a risk of damage to property. Do not use oil additives.



*NOTE: Use a clean funnel when refilling the vehicle with oil to prevent spillage. Spilling oil onto hot components like the exhaust can lead to ignition. If a fire occurs in the engine bay, close the bonnet if safe and call the fire service from a safe distance.*

The vehicle's oil level is electronically monitored, and the driver is notified when it's low and needs topping up. It's crucial not to regularly drive the vehicle with low oil. If the low oil warning persists after topping up, there may be a fault. In such cases, consult your nearest INEOS approved partner immediately and refrain from driving until the issue is resolved.



**WARNING:** The Diesel B57 engine does have a dipstick in the engine bay, however this must NOT be used to check engine oil level.

## MAINTENANCE AND TECHNICAL INFORMATION

The oil level for Petrol and Diesel engines are monitored electronically. The driver can view the oil level within the vehicle information using the infotainment screen. The oil level will be shown to the driver using the following values:

OIL LEVEL	VALUE SHOWN
Motor oil level at a minimum	MIN
Level 1	25 %
Level 2	50 %
Level 3	75 %
Motor oil level full	100 %
Motor oil level overfilled	SPILL
Motor oil level OK	OK
Service function active	FUNC

To access the oil level information, go to the infotainment screen, select "SETTINGS," then "VEHICLE FUNCTIONS," and finally 'VEHICLE INFORMATION'. From there, choose "Engine Oil" to view details like temperature, level on-road, and level off-road.

INFORMATION'. From there, choose "Engine Oil" to view details like temperature, level on-road, and level off-road.

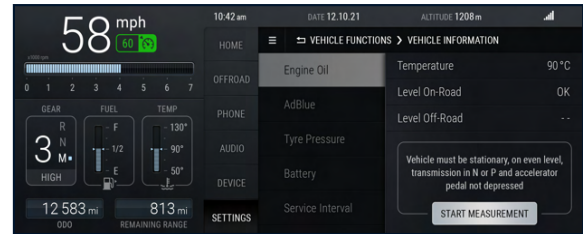

Before measuring the engine oil level, follow the instructions displayed on the infotainment screen above the 'START MEASUREMENT' button. Once ready, press the button to begin the measurement process.

If the vehicle is unable to perform an engine oil level check, the 'START MEASUREMENT' button will be greyed out. Ensure that the instructions displayed above the button are followed, and that the vehicle is in the specified conditions, such as stationary and in Park, before attempting again.

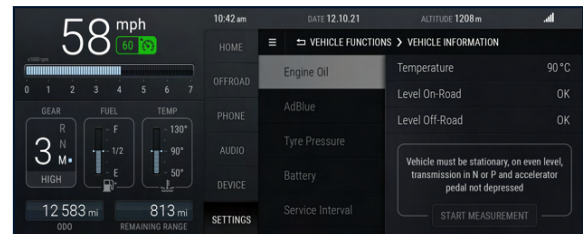

## MAINTENANCE AND TECHNICAL INFORMATION

If there is an issue or the predefined conditions are changed, such as, the vehicle is removed from Park. Then the measuring of the engine oil will be aborted.

After successfully measuring the engine oil, the infotainment screen will display the results next to 'Level On-Road' and 'Level Off-Road'. In the provided image, both engine oil levels are indicated as 'OK'.

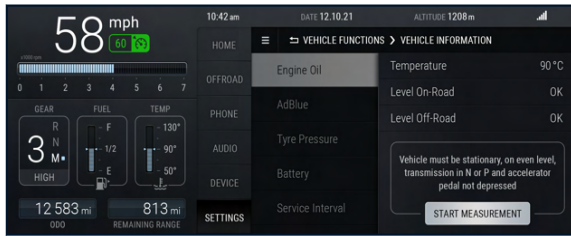

If the engine oil temperature is too high, then the infotainment screen will display the 'Temperature' text in red, and the temperature will be displayed for the driver to see.

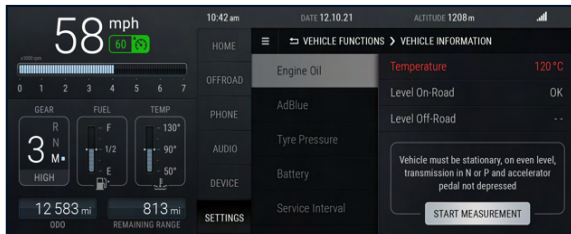

**i** *NOTE: If the system does not read the engine oil level and/or there is an issue with the level of the engine oil. Consult immediately with your INEOS approved Partner.*

To add engine oil to the engine, follow this procedure:

1. Locate the oil cap in the engine bay.
2. Turn the cap counter-clockwise and remove it.
3. Add the INEOS approved engine oil.
4. Replace the cap and tighten clockwise, do this until there is a resistance and the cap is secured.
5. Now check the engine oil level again to ensure the correct level of oil is achieved.

**i** *NOTE: The capacity difference between minimum and maximum fill levels is approximately 1 litre (33.8 fl oz) of oil.*

SERVICE FILL QUANTITY	OIL SPECIFICATION
6,5 L (1.7 gal)	SAE 0W-20, ACEA C2, BMW LL-17 FE

SERVICE FILL QUANTITY	OIL SPECIFICATION
7,5L	SAE 0W-30, ACEA C2, BMW LL-12 FE

## MAINTENANCE AND TECHNICAL INFORMATION



*NOTE: To ensure the correct engine oil is used and the proper quantity is added to the vehicle, consult with your nearest INEOS approved partner.*

### Engine Oil Viscosity Grades

The Society of Automotive Engineers (SAE) viscosity grade gives information for the thickness of the oil. Multi-grade oil is indicated by two figures, e.g. SAE 5W-30. The first figure, followed by a W, indicates the low temperature viscosity determined by the oil's flow at 0 degrees Fahrenheit or -17.8 degrees Celsius. The 'W' stands for winter, so the lower the number before the 'W' the less it thickens in cold temperatures. The second figure is the high temperature viscosity, this is determined by the oil's flow measured at 212 degrees Fahrenheit or 100 degrees Celsius, this number represents the oil's resistance to thinning at high temperatures. It is essential to select the appropriate viscosity grade oil depending on the minimum ambient temperature. All of the recommended viscosity grades are suitable for high ambient temperatures.

### Engine Coolant Check and Refill



**WARNING: Operating materials are hazardous and could be poisonous. Handle with care. Pay attention to information given on the containers.**



**WARNING: Do not remove the filler (pressure) cap until the coolant system has cooled down. Scalding can be caused by escaping steam and/or coolant.**



**CAUTION: Coolant additives can damage the coolant system. There is a risk of damage to property. Do not use coolant additives.**



*NOTE: When removing the coolant fluid cap it is advised to use a cloth or heat and liquid proof gloves to protect hands and arms adequately.*

There are two coolant reservoirs in the engine bay: the main coolant reservoir for high temperature components and the auxiliary reservoir for low temperature components. While they operate independently, if one consistently requires more coolant than the other, it may indicate a malfunction and should be inspected by an INEOS approved partner.

1. Remove the coolant cap by rotating anti-clockwise, until the cap is removed. To check the levels of fluid notice there is a low and maximum level indicator visible on the inside of the tank itself.
2. Add the correct specified coolant fluid to the reservoir, until the level reaches the maximum marker. It is important not to overfill the reservoir above the maximum or leave the coolant level below minimum.
3. Once appropriately filled re-apply the coolant cap by rotating clockwise until tight.



*NOTE: Over tightening the cap can damage the thread on the bottle and the cap itself.*

# MAINTENANCE AND TECHNICAL INFORMATION

## Diesel Water Separator (OPTIONAL)



**WARNING:** Take care to not splash any water or fuel onto the face, in particular the eyes and mouth. Immediately wash liquid from the face safely and seek medical advice.



**WARNING:** The vehicle must be switched off completely before unplugging the electrical connector to access the drainage plug.



**WARNING:** Make sure the vehicle has been switched off and the car has cooled down until cold. Failure to do this can result in burns to the body from hot liquid or by touching components, such as, the exhaust pipes under the vehicle.



**CAUTION:** Do not pull on the wiring when releasing the electrical plug from the water separator. This can damage the electrical plug, consult with an INEOS approved partner if this happens.

Drain the water separator before driving and after driving off road. This ensures that the water separator does not fill and trigger any warning lamps or messages on the infotainment screen.

Water separator draining procedure:

1. Remove the electrical plug from the underside of the water separator.
2. Put an empty reservoir under the water separator.

3. Open and remove the draining plug. Take care when removing the drainage plug, as water and some fuel may immediately spill from inside the water separator.
4. Allow the water separator time to completely drain of water and fuel.
5. Close the water separator by re-assembling the drainage plug to the water separator.
6. Plug the electrical connector back into place.



*NOTE: The drained liquid may contain fuel, it is essential that the liquid is disposed of safely in an environmentally friendly location.*



*NOTE: Take care that no fuel goes onto the ground.*

If the Diesel Water Separator is full, then the vehicle will warn the occupants by displaying a warning message on the infotainment screen. The following tell-tale lamp  will be illuminated yellow, to ensure the driver can see that there is an issue.

## Brake Fluid





**WARNING:** Do not drive the vehicle if the brake fluid is below the minimum mark.

## MAINTENANCE AND TECHNICAL INFORMATION

 **WARNING:** Operating materials are hazardous and could be poisonous. Handle with care. Pay close attention to information given on the containers.

 **WARNING:** Wear protective clothing such as gloves when using corrosive substances to protect the hands and arms.

 **CAUTION:** Brake fluid is very corrosive. If there is a spillage then the area should be cleaned straight away with clean water and a clean damp cloth. If left the fluid can damage and remove paint or eat into metals.

 **CAUTION:** Do not apply the brakes suddenly or intermittently after a the brake system has been serviced. This includes, but not limited to, brake pad, brake disc replacements and/or brake fluid replacement. If you do, the performance and life of the brake pads and discs can be negatively affected.

The brake fluid reservoir will have a minimum and maximum level indicator or marking. The fluid level should be between the minimum and maximum markings, never below minimum or above maximum. If the fluid is below the minimum mark, a warning message will appear and the brake tell-tale lamp will illuminate. To top up the brake fluid:

1. Remove the Reservoir cap.
2. Fill brake fluid up to the maximum level.
3. Install the reservoir cap securely.



*NOTE: If the brake system has been serviced or the pads and/or discs have been replaced, make sure that you apply the brakes carefully and gradually for 300 miles (500km) to complete the bedding in process.*

### Brake Pad Wear Indication



**WARNING:** If there is a brake warning lamp illuminated, immediately consult with an INEOS approved partner. Continuing to drive the vehicle can result in further damage to the vehicle, or even a crash resulting in injury or even death.



**CAUTION:** If the brake wear sensor has been activated and the brake pads need replacing, contact an INEOS approved partner immediately to have the brake system checked and the pads replaced.



**CAUTION:** Do not apply the brakes suddenly or intermittently after a the brake system has been serviced. This includes, but not limited to, brake pad, brake disc replacements and/or brake fluid replacement. If you do, the performance and life of the brake pads and discs can be negatively affected.



**CAUTION:** If the brake system has been serviced or the pads and/or discs have been replaced, make sure that you apply the brakes carefully and gradually for 300 miles (500km) to complete the bedding in process.



## MAINTENANCE AND TECHNICAL INFORMATION



**CAUTION:** If you suspect that there is an issue with the brake system, the pads may be at a low level or there is uneven pad wear, please consult immediately with your nearest INEOS approved partner.

The brake pad wear sensor warns the driver when the brake pad wear exceeds a tolerable limit. The brake tell-tale lamp  will illuminate to signal to the driver that there may be a malfunction and/or the brake pads have been reduced to a critical level.

### Replacing Wiper Blades



**WARNING:** When removing the blade from the swivel arm, INEOS recommend that windscreen protection is used to avoid accidental damage.

When installing a new wiper blade, safeguard against accidental damage by using a protection mat. Lift the wiper arm away from the windscreen or rear window (if applicable), then press the retaining clip and slide the blade away from the arm to detach it. Place the new blade assembly onto the arm, secure it to the swivel bracket, and push it in until it's held by the clip. Finally, remove the protection mat and verify that the replacement blades match the original specifications.



**NOTE:** INEOS recommends having the vehicle's window wipers replaced as needed by an INEOS approved partner, who will also inspect them for defects or wear during each service. Additionally, it's advised to transport

*the vehicle to the INEOS approved partner in fair weather to avoid driving in hazardous conditions without fully functional window wipers.*

### FUEL



**CAUTION:** It is essential to use the correct fuel in the vehicle. If you do not use the correct fuel, then you could damage the fuel system and the engine.



**CAUTION:** Do not use E85 fuels in the vehicle. Using E85, may cause damage to the fuel system. If E85 fuel is put into the tank, consult your nearest INEOS approved partner immediately.



**CAUTION:** Fuel additives can damage the fuel system and the engine. There is a risk of damage to property. Do not use fuel additives.



## MAINTENANCE AND TECHNICAL INFORMATION

The recommended fuel for the petrol engine is 95 RON unleaded, but a minimum of 91 RON unleaded can be used.



The recommended fuel for the diesel engine is B7. Use Diesel that meets the specification defined by EN 590, or the relevant national specification.



-  *NOTE: Unleaded petrol, meeting specification EN228, with a maximum ethanol content of 5% or 10% may be used.*
-  *NOTE: Diesel fuel, meeting specification EN590, with a maximum bio-diesel content of 7% may be used.*

### Fuel Safety

-  **WARNING:** Do not create a spark, flame or heat near a fuel. There is a risk of fire or explosion leading to serious injury or even death.

# MAINTENANCE AND TECHNICAL INFORMATION

## Fuel Economy

It is essential to maximise the fuel economy of the vehicle. To do this, the following points must be considered before driving your vehicle.

- > Acceleration.
- > Speed.
- > Braking.
- > Regular maintenance.
- > Weather.
- > Start/stop short journeys.
- > Terrain.
- > Four wheel drive.
- > Luggage and towing.
- > Running electrical accessories and features.

To optimize fuel economy, accelerate gently and adhere to road speed limits. Rapid acceleration and speeding increase wind resistance, leading to higher fuel consumption. Additionally, avoid heavy and abrupt braking, as it can decrease fuel efficiency. Instead, brake gently and anticipate stops to improve fuel economy.

It is important to maintain the vehicle, servicing the vehicle regularly will help keep the vehicle economical. The following points will decrease the vehicles economical performance, if not correct:

- > Tyre pressure.
- > Wheel alignment.
- > Oil condition.
- > Air filter Condition.
- > Fuel filter condition.

Cold weather and short trips can reduce fuel efficiency as the engine takes time to warm up. Driving on uneven or wet surfaces increases resistance and affects economy. Carrying heavy luggage, using roof racks, or towing a trailer can also impact fuel efficiency. Additionally, running electrical accessories like air conditioning on 'MAX' decreases fuel economy.

## Fuel Tank and AdBlue Capacity

FUEL / LIQUID	FUEL CAPACITY
Petrol	90 L
Diesel	90 L
AdBlue	17 L

# MAINTENANCE AND TECHNICAL INFORMATION

## ELECTRICAL SYSTEMS

### Battery

Vehicle Battery: 12v105Ah EFB H9

The vehicle battery is maintenance free and should only require checking by your INEOS approved partner during regular vehicle service intervals.

### Battery Information

 **WARNING:** Always wear protective clothing, such as, gloves and arm coverings when handling batteries. Failure to do so can result in injury.

 **WARNING:** Keep batteries out of reach of children.

 **WARNING:** Batteries contain sulphuric acid. Avoid contact with skin, eyes or clothing. Shield your eyes when working near the battery to protect against possible splashing of acid solution. In case of acid contact with skin or eyes, flush immediately with water for a minimum of 15 minutes and get prompt medical attention. If acid is swallowed, get medical help immediately.

 **WARNING:** When lifting a plastic cased battery, excessive pressure on the end walls could cause acid to flow

through the vent caps, resulting in personal injury, damage to the vehicle or battery. Lift the battery with a battery carrier or with your hands on opposite corners.

 **WARNING:** Never place metal objects on the battery or allow the positive terminal of the battery to contact parts of the vehicle body. This can create a spark or a short circuit which can ignite gases created when the battery is charged.

 **WARNING:** Electrostatic charge can cause sparks, which may ignite the highly flammable gas mixture within the battery.

 **WARNING:** Keep the battery away from flames, sparks, or lighted substances. Batteries normally produce explosive gases when charging or when jump started. Always have sufficient ventilation.

 **WARNING:** Be sure to wear gloves when handling battery posts, terminals and related accessories as they contain lead compounds. Even after wearing gloves make sure you wash your hands after handling.

 **CAUTION:** The engine must never be run with the vehicle battery disconnected. This can cause damage to vehicle electrical modules.

 **CAUTION:** Apart from vehicle recovery, this vehicle must not be driven if the vehicle battery is incapable of

# MAINTENANCE AND TECHNICAL INFORMATION

starting the engine. In this case the vehicle battery must be replaced. Contact your INEOS approved partner.



**CAUTION:** INEOS does not recommend replacing the Lead-Acid starter battery with an LFP (LiFePO<sub>4</sub>) battery.

## Changing the Battery



**CAUTION:** INEOS does not recommend replacing the Lead-Acid starter battery with an LFP (LiFePO<sub>4</sub>) battery.



**NOTE:** INEOS recommends that you have the 12v battery replaced by an INEOS approved partner. If you want to change the battery yourself, then you must observe the following notes first:

- > Only replace the battery with one that is exactly the same specifications, meeting the correct requirements.
- > Carry over detachable parts, such as vent hoses, elbow fittings or terminal covers from the battery being replaced.
- > Make sure the vent hose is always connected to the original opening on the battery.
- > Install any existing or supplied cell caps.
- > Make sure that detachable parts are reconnected in the same way before they were removed.

## Battery Level Protection



**CAUTION:** If the battery is not capable of starting the engine, replace the battery as soon as possible.

The vehicle is equipped with an Intelligent Battery Sensor (IBS) that monitors battery voltage, current, and acid temperature. If the battery capacity becomes critically low, the sensor alerts the ECU, displaying a warning on the infotainment screen. If you receive a low battery warning, start the engine to allow it to recharge the battery, or use a suitable battery charger or conditioner. Alternatively, drive the vehicle for at least thirty minutes to replenish the battery charge. If the battery capacity remains critical, it's advisable to consult an INEOS approved partner for a battery health check.

## Battery Disposal



**WARNING:** Improper disposal of batteries could cause serious injury.



**WARNING:** Do not dispose of a battery in fire or water.



**NOTE:** Environmental damage is caused by improper disposal of batteries.



**NOTE:** Do not dispose of batteries with your household rubbish as this is illegal.

## MAINTENANCE AND TECHNICAL INFORMATION

Batteries contain pollutants and can be hazardous to your health and the environment. Most batteries contain materials that, when disposed of incorrectly, may leak into the environment. This can contribute to soil and water pollution and endanger wildlife.

Dispose of batteries in an environmentally responsible manner and follow your local authorised standards for disposal. Call your local authorised recycling centre to find out more about recycling automotive batteries.



*NOTE: If you have to disconnect the 12v battery, INEOS recommends you contact an INEOS approved partner for support.*

### Auxiliary Battery (OPTIONAL)



**WARNING: If water enters the battery and fuse compartments, do not attempt to touch the components and seek further advice from your INEOS approved partner. Failure to do so may result in serious injury or death.**

The Auxiliary Battery is connected to the vehicle's electrical system but isolated from the starter circuit. The Auxiliary Battery is used as a safety back-up to support the main battery when required or to provide voltage for specific vehicle systems.

The Auxiliary Battery protects the vehicle as it prevents a voltage drop when cranking the engine.



**WARNING: If the replacement of the batteries is not carried out in the correct sequence, then there is a risk of a short circuit and/or damage to the batteries and electrical parts and/or components. Please follow these instructions closely to avoid damage to the vehicle and the risk of injury.**

1. Disconnect the ground connection to the Battery Combiner.
2. Remove the Negative (-) terminal on both the Start and Auxiliary Battery. Never allow contact between the Battery Cables and conductive metal parts, for example, the vehicle body.
3. Perform Service Work.
4. Re-assemble in the opposite order.
5. Check that there is no fault indication on the Battery Combiner LEDs.
6. Never operate the vehicle with only one of the batteries connected, as this can lead to contact with unprotected conductive metal parts. If there is an emergency situation requiring the vehicle to be used with one battery only, then ensure the connector cables are insulated and secured away from conductive metal parts.

## MAINTENANCE AND TECHNICAL INFORMATION

---

### 400W Power Inverter (Optional)



**WARNING:** Do not expose the 400W Power Inverter to water or moisture. Failure to do so can result in damage to the vehicle and/or serious injury.



**WARNING:** Do not expose to water when hosing down the vehicle. Take care not to splash or direct water at the 400W Power inverter or the outlet sockets.



**WARNING:** Do not operate the 400W Power Inverter if you, the 400W Power Inverter, the device being operated, or any other surfaces that may come in contact with any power source are wet.



**WARNING:** Ensure the area around the 400W Power Inverter is well ventilated and clean of debris. Failure to do this can result in the build up of flammable gases and/or the 400W Power Inverter reaching high temperatures.



**WARNING:** Do not touch any water or moisture near the power outlets or the 400W inverter. Water and many other liquids can conduct electricity which may lead to serious injury or death.



**WARNING:** 230V of electricity can be lethal. Improper use of a power inverter, will result in property damage, personal injury, or loss of life.



**CAUTION:** Do not plug devices into the outlet sockets if they require more than 400W. This can result in damage to the vehicle.

The 400W Power Inverter is a device that converts the DC power from your vehicle to AC power and is an essential step required to power any domestic devices using the outlets. The 400W Power Inverter is rated to output 400 Watts at its peak rate.

The benefit of the power inverter is having domestic outlets located in the passenger compartment and the Loadspace of the vehicle. This means you can charge and/or power devices that require up to the maximum 400W rating e.g. a personal laptop device without a nearby mains outlet. This being particularly useful when taking the vehicle off-road and/or camping off-grid.

The 400W outlet sockets can be located in the following locations:

## MAINTENANCE AND TECHNICAL INFORMATION

---

Back of the Centre Console:

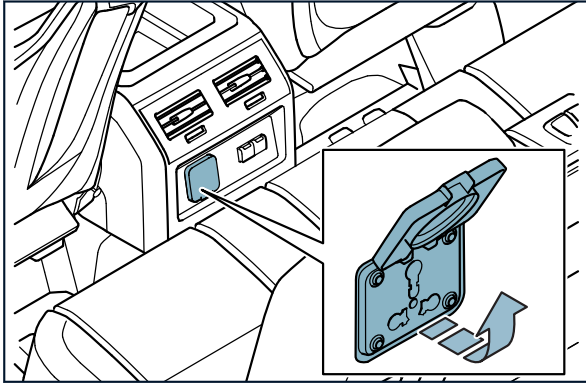

Loadspace:

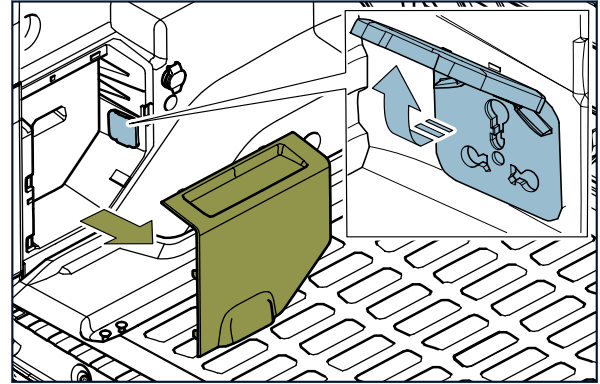



## MAINTENANCE AND TECHNICAL INFORMATION

For the Quartermaster, the Loadspace power outlet is located in the Loadbay, as seen in the following image:

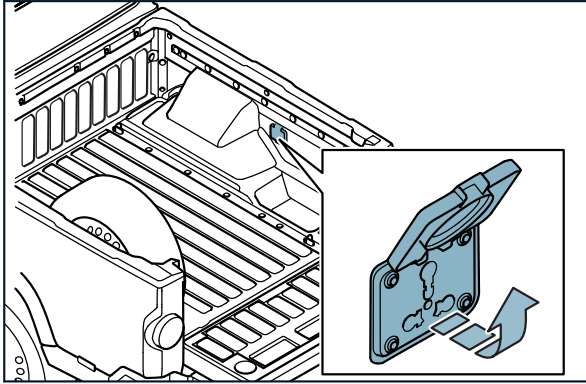

**i** *NOTE: Power could be limited during extreme hot or cold temperatures to optimise system performance.*

**i** *NOTE: When spraying water in and around the Loadbay, only spray from the front of the cover. The cover may be forced open by water pressure, if sprayed from other angles.*

\*Not applicable to the Double Cab Chassis

### Auxiliary Switch Panel and Electrical Preparation

- !** **WARNING:** Do not attempt to modify the wiring harness. If components are damaged and/or need replacing please seek further advice from your INEOS approved partner. Failure to do so may result in serious injury or death.
- !** **WARNING:** Do not splash any electrical wires or connectors. If any electrical wires or connectors are exposed to moisture, they might corrode and break or result in a system failure.
- !** **WARNING:** Take care when using or working around electrical equipment, 10 amps can result in serious injury and/or even death. Wear protective clothing, such as, rubber insulating gloves to protect you from being shocked.
- !** **WARNING:** Ensure the vehicle power is switched off and that the battery is removed for safety. Failure to do so may result in serious injury, death and/or damage to the vehicle.
- !** **CAUTION:** Always check the electrical accessories power requirements and consult the accessory manual before connecting to the vehicle's power supply.

## MAINTENANCE AND TECHNICAL INFORMATION

The vehicle comes with three pre-wired 10amp electrical provisions, one in both the driver and front passenger foot-well, and one located under the bonnet.

The interior 1 and 2 provisions (Switch 'INT 1' and 'INT 2' on the Overhead Control Panel), both terminate in the front left and front right foot-wells. They can be found behind the foot-well side trim piece and are wiring preparations consisting of a heat shrunk cable end, from which 3rd party outlets can be attached, to then power devices.

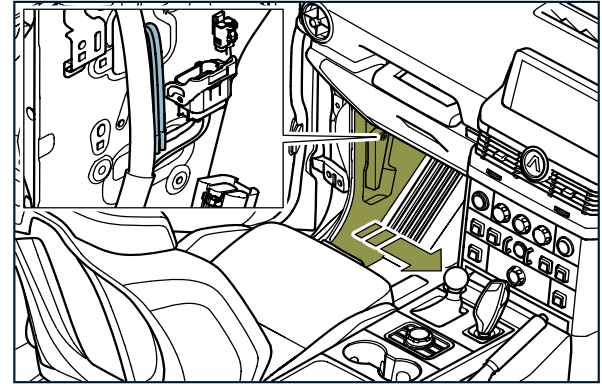
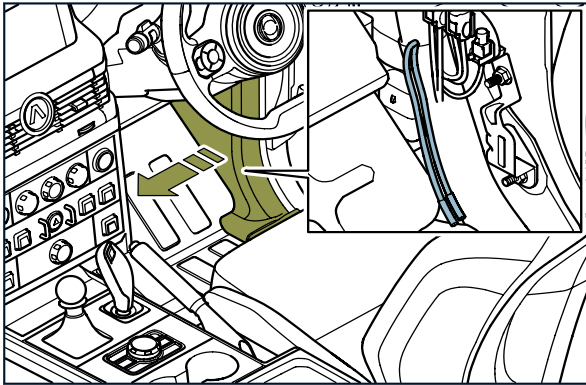

Exterior 1 (Switch 'Ext 1' on the Overhead Control Panel) is located under the bonnet, near to the brake fluid reservoir. This is wiring preparations consisting of a heat shrunk cable ends, from which 3rd party outlets can be attached, to then power devices.

### High Load Auxiliary Switch Panel and Electrical Preparation (OPTIONAL)



**WARNING:** The rear high amp outlet (NATO outlet) is intended for use with the Removable Rear Winch (Accessory) only. Do not connect any other equipment to the rear high amp outlet (NATO outlet). Connecting equipment other than the Removable Rear Winch (Accessory) available through INEOS Automotive will be

## MAINTENANCE AND TECHNICAL INFORMATION

categorised as misuse and can result in serious injury and/or death.



**WARNING:** INEOS Automotive will not be held responsible for any damages, injuries and/or deaths that occur from or relating to the operation of the rear high amp outlet (NATO outlet) outside of the intended purpose.



**WARNING:** Do not remove any debris and/or mud from the rear high amp outlet (NATO outlet) until the power isolator has been switched off. Failure to do so can result in serious injury and/or death.



**CAUTION:** When connecting electrical accessories to the auxiliary outlets, ensure the connection is free of dirt, debris and moisture. Failure to do so, will result in poor conductivity.



**CAUTION:** The rear high amp outlet (NATO outlet) cover may periodically need lubricating to prevent seizure. INEOS Automotive recommends using Vaseline® or a neutral based grease product. Care should be taken that the vehicle power is first turned off before applying, and no grease residue is left on the contacts or connector body.

The High Load Auxiliary Switch Panel & Electrical Preparation comprises an extra 25A provision under the bonnet, a 500A provision (for the front winch if specified) and a 350A NATO outlet at

the rear of your Grenadier (for the accessory winch, if specified). For the Station Wagon, there are four roof outlets, and for the Quartermaster, there are two roof outlets in the roof-rail recesses running on two 25A circuits.

Roof Rail Power Outlets locations on the Station Wagon:

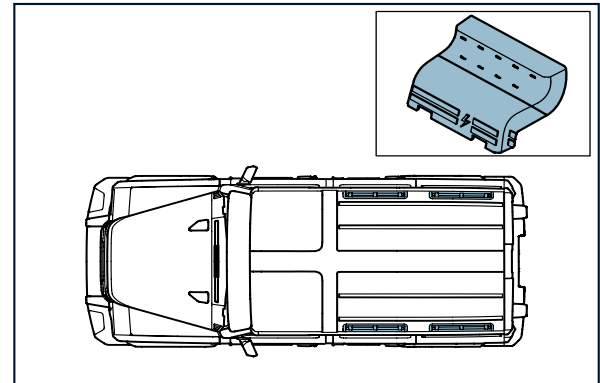

### Premium Sound System (OPTIONAL)

The Premium Sound System provides a sub-woofer under the Rear Bench Seat (flat floor in 2-seat vehicles).

### Technical Specifications:

## MAINTENANCE AND TECHNICAL INFORMATION

Speakers	6" x 8" (152mm x 203mm)
Power	100Wrms (200W maximum)
Crossover Frequency	50Hz - 150Hz
Crossover Slope	12dB/octave
Bass Boost	0dB to +12dB at 50Hz

### Other Technical Specifications:

- > Frequency Response 30Hz - 150Hz.
- > Fuse: 15A.
- > Maximum Current Draw <600mA
- > Input Sensitivity: 0.1V - 4.0V Low-Level Input; 0.25 - 10V High-Level Input.
- > Dimensions (L x W + H): 10-1/4" x 7-11/16" x 2-15/16" (260.0mm x 195.0mm x 74.6mm).
- > Weight: 7.78 lbs (3.53kg).

### Front 12V Socket

One 12V socket comes as standard in the front of the vehicle, located in the central storage tray.

\*Not applicable to the Double Cab Chassis

### Fuses

Fuses are installed to your Grenadier to prevent damage to electrical circuits. If too much current is supplied to a fused circuit, the fuse will blow, breaking the circuit. This reduces the risk of damage and accident.

Fuses are found in three locations: a panel under the Ignition Switch, in the engine compartment, and next to the main battery under the left rear seat.

If a fuse blows, the device to which it is connected will not work. Replace the fuse or have an INEOS dealer replace it for you. If the same fuse blows again, consult your INEOS dealer.

## MAINTENANCE AND TECHNICAL INFORMATION

The following image and table show the locations, related system/device, and amp rating of the fuses inside the Cockpit Electrical Centre Fuse Box under the Ignition Switch.

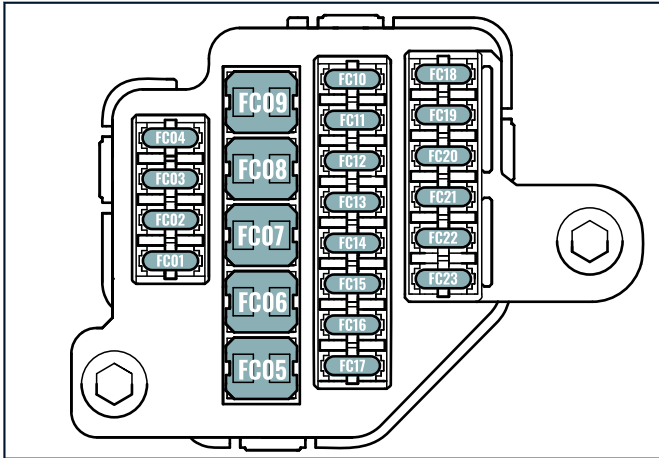

FUSE POSITION	DESCRIPTION	AMPERAGE
FC01	Gear Selector	5
FC02	Cluster / Glove Box / Steering Wheel	7.5
FC03	HVAC Module	7.5

FUSE POSITION	DESCRIPTION	AMPERAGE
FC04	Clock / Theft Alarm / Logistics	5
FC05	Body Control Module 1	40
FC06	Body Control Module 2	30
FC07	Additional Heater Step 3	40
FC08	Additional Heater Step 2	40
FC09	Additional Heater Step 1	40
FC10	Reserved	FREE
FC11	HVAC Module	7.5
FC12	Head Unit	20
FC13	Emergency Call	5
FC14	Ignition Switch / Steering Wheel	10
FC15	On-board Diagnostics (OBD-II)	10
FC16	Reserved	FREE
FC17	Reserved	FREE
FC18	Reserved (Diagnostics)	FREE
FC19	Reserved	FREE
FC20	Reserved	FREE

## MAINTENANCE AND TECHNICAL INFORMATION

FUSE POSITION	DESCRIPTION	AMPERAGE
FC21	12V Front Outlet	15
FC22	USB Charging	5
FC23	12V Rear Outlet	15

The following image and table show the locations, related system/device, and amp rating of the fuses inside the Interior Electrical Centre Fuse Box under the left rear seat.

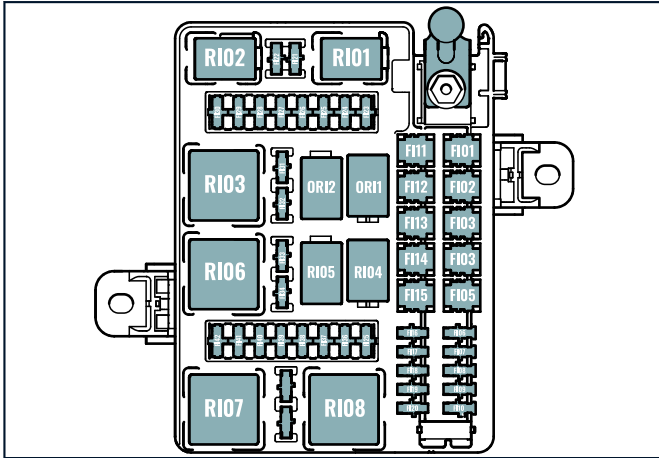

FUSE POSITION	DESCRIPTION	AMPERAGE
FI01	IGN Relay (CL15 - Electronics)	30
FI02	IGN Relay (CL15 - Pumps / Heating)	60
FI03	Front Wiper Motor	30
FI04	Accessory Relay (CL30ACC - R103)	60
FI05	Horn (BCM)	20
FI06	Window Lifter FL (BCM)	30
FI07	Window Lifter FR (BCM)	30
FI08	Window Lifter RL (BCM)	30
FI09	Window Lifter RR (BCM)	30
FI10	After Run Relay (CL30S - R102)	25
FI11	Rear Defog	30
FI12	HVAC (Blower)	40
FI13	Amplifier / Trailer Brake Provision	40
FI14	Trailer Module	40
FI15	SCR Module 1	30

## MAINTENANCE AND TECHNICAL INFORMATION

FUSE POSITION	DESCRIPTION	AMPERAGE
FI16	Gateway Module 1 (ETGW)	30
FI17	Water Separator	25
FI18	Fuel Pump	30
FI19	Gateway Module 2 (ETGW)	15
FI20	Door Lock	20
FI21	Seat Heating Right	25
FI22	Seat Heating Left	25
FI23	Cooling Fan / AC Compressor	5
FI24	Amplifier	20
FI25	Trailer Brake Provision	25
FI26	SCR Module 2	15
FI27	Brake Light Switch	5
FI28	Overhead Console Switch	10
FI29	LHS Foot-well	10
FI30	RHS Foot-well	10
FI31	Trailer	25
FI32	Heated Mirrors	7.5

FUSE POSITION	DESCRIPTION	AMPERAGE
FI33	Loadspace Lamp / IBS / NVLD	5
FI34	Front Camera (ADAS)	5
FI35	Run Crank - Steering / ESC / Brake Fluid Sensor	7.5
FI36	Airbag Control Module	10
FI37	Run Crank - BCM / ETGW / Seat Mat / Park Assist / Rear View Camera	7.5
FI38	Power Mirrors	5
FI39	Headlamp Levelling	10
FI40	Run Crank - HVAC / Cluster / Steering	7.5
FI41	Fuel Pump Controller / Exhaust Flap / Water Separator	5
FI42	Front Wiper / Rear Wiper	15
FI43	Water Pump	10

## MAINTENANCE AND TECHNICAL INFORMATION

The following image and table show the locations, related system/device, and amp rating of the fuses inside the Under-hood Electrical Centre Fuse Box.

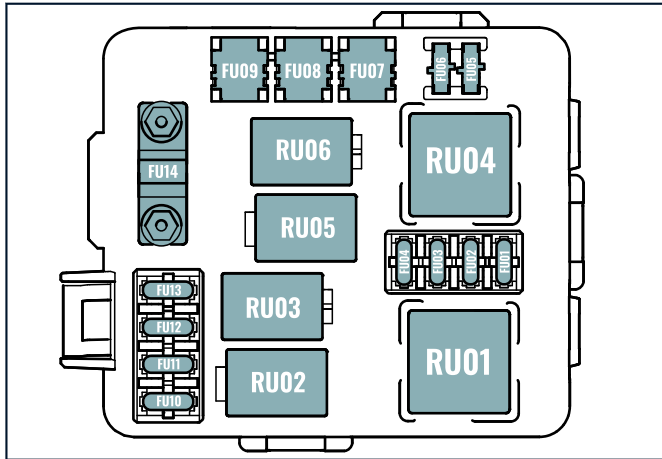

FUSE POSITION	DESCRIPTION	AMPERAGE
FU01	Reserved	Free
FU02	Transmission	20
FU03	Reserved	FREE

FUSE POSITION	DESCRIPTION	AMPERAGE
FU04	A/C Compressor	10
FU05	Gateway Module (ETGW)	5
FU06	Engine Cooling Fan	15
FU07	Electronic Stability Control (Valves)	40
FU08	Washer Pump	30
FU09	Starter Motor	30
FU10	Reserved	FREE
FU11	Reserved	FREE
FU12	Reserved	FREE
FU13	Horn - Toot	7.5
FU14	Electronic Stability Control (Motor)	60

The Amp rating of each fuse is signalled by a colour to help identify the maximum current capacity of a fuse. The following table explains the fuse colours and the amp rating they signify.



## MAINTENANCE AND TECHNICAL INFORMATION

FUSE	CURRENT RATING
Black	1A
Grey	2A
Violet	3A
Pink	4A
Tan	5A
Brown	7.5A
Red	10A
Blue	15A
Yellow	20A
Clear	25A
Green	30A
Aqua Blue	35A
Orange	40A
Red	50A
Blue	60A
Tan	70A
Clear	80A

### EXTERIOR CARE

#### Washing



**WARNING:** Wash the vehicle only when it has cooled down, ensuring that the panels are also cool.



**WARNING:** Use only cold or lukewarm water; do not use hot water.



**CAUTION:** High-power pressure cleaners can penetrate window seals and doors. Avoid aiming the pressure washer blast directly at components that may be penetrated or damaged.



**WARNING:** Use of high pressure cleaners could cause damage to the paintwork and other exterior fittings.



**CAUTION:** Ensure the heater blower is turned off to prevent damage or contamination of the fresh air filter.

Regularly washing the vehicle is crucial to maintaining the condition of the body panels, underside, inner wheel arches, and wheels. This is especially important in winter when roads are salt-treated, requiring thorough washing of the underside and inner wheel arch areas to clear harmful contaminants that can lead to corrosion or damage. Frequent washing is also recommended for off-road or

## MAINTENANCE AND TECHNICAL INFORMATION

wading conditions to ensure harmful contaminants are removed from the underside and lower bodywork, including the wheel areas.



*NOTE: After washing the brake calipers and brake discs, it's recommended to drive the vehicle briefly to prevent corrosion and ensure any water or cleaning products are dried and removed from the brake systems and components.*



*NOTE: A thin layer of oxidized material may form on the brake discs if left to dry without driving the vehicle. This is normal and should not affect the performance of the brakes.*

When washing the vehicle, adhere to the following guidelines from INEOS:

- > Do not use household soaps or detergents.
- > Avoid directing water hoses or pressure washers at full force around the doors, bonnet, and Safari Window seals (if applicable) to prevent seal failure.
- > Avoid using a brush on the vehicle body as it may scratch the paintwork and lamp lenses.
- > Avoid washing the vehicle in direct sunlight.
- > Allow the vehicle to cool before washing.

To wash the vehicle effectively, follow these steps:

1. Pressure wash or hose down the vehicle to remove clumps or mud, debris, or road dust.
2. Add mild neutral detergent to a bucket of water, following the detergent manufacturers instructions.
3. Fill a second bucket of water for rinsing.
4. Soak a large clean wash mitt in the detergent mixture and apply it to the vehicle, working in small sections from the top down.
5. Rinse the wash mitt frequently in the rinse water bucket to prevent a buildup of mud and grit, which can damage the paintwork.
6. If the vehicle has been used for off-roading or wading, repeat the washing process multiple times.
7. For extremely dirty vehicles, hose down each section or panel after washing to ensure all contaminants are removed.
8. Keep the vehicle wet throughout the washing process to prevent detergent water from drying and leaving stains or water marks.
9. After washing, thoroughly rinse the vehicle with a pressure washer or hose to ensure all areas are clean and no dirty water is trapped.
10. Finally, dry the vehicle with a soft drying towel to prevent water spots, and allow it to air dry if needed.

# MAINTENANCE AND TECHNICAL INFORMATION

## Glass and Mirror



**CAUTION:** Do not scrape the inside of the rear window or use abrasives or chemical solvents to clean it. This will cause damage to the heating elements.

After washing the vehicle, using a soft, lint free cloth wipe and clean the windows of the vehicle, use a window cleaner designed for vehicle use, but follow the instructions of the manufacturer carefully.

Do not use abrasive cleaning compounds or scrapers to clean the mirrors in and around the vehicle as they are susceptible to damage, if care is not taken.

## Paint Work



**WARNING:** Any vinyl or stickers applied to the vehicle may result in damage to the paintwork.



**WARNING:** Any paint work repairs other than touching in small minor stone chips should be carried out by an INEOS approved partner.

Modern water based paints are more susceptible to contamination and marking by corrosive substances, however they are much safer and more environmentally friendly than solvent based paints.

The most common contaminants which may adversely affect your paint work are listed below:

- > Bird droppings
- > Insect remains
- > Oil and Greases
- > Brake Fluid
- > Tree sap and pollen
- > Antifreeze
- > Resin
- > Tar
- > Salt.



*NOTE: The list of contaminants may be added to over time as this list is not exhaustive of the contaminant groups that might adversely effect the paint work.*

Wash any of the listed contaminants off the vehicle immediately, use warm water and vehicle shampoo where possible. During the warmer summer months it is particularly important to wash any contaminants off the vehicle at the earliest opportunity to avoid the sunny weather from accelerating any contamination effects on the paint work.

Minor paintwork damage such as minor stone chips can be touched up using a touch-up pen before rust forms and leads to corrosion.

# MAINTENANCE AND TECHNICAL INFORMATION



**WARNING:** Any paint work damage repairs should be carried out by a qualified body shop professional. Contact your nearest INEOS approved body repair centre for further advice.

## Road Wheels

The wheels, wheel nuts and centre trims, should be cleaned regularly to avoid build up of dust, mud and salts from road use, off-roading and wading. Use a pH- neutral wheel cleaner or a mild soapy water solution to avoid damaging the wheel or wheel paint and coatings. When washing the wheels make sure any solution used does not dry fully before rinsing off with clean water.

## Headlamp Lenses

Clean the headlamps using a soft cloth and mild soapy water. Do not use any cleaning products containing solvents, abrasives or caustic agents. Do not clean the headlamp lenses using a dry cloth, always use mild soapy water and do not use a scraper to avoid scratching of the lens.



*NOTE: Always clean the headlamps after off-roading and wading for maximum lighting in all conditions. Failure to do this can result in an incident or crash.*

## Under Bonnet Cleaning

Under bonnet cleaning should be done with engine bay cleaner, always follow the instructions of the engine bay cleaner carefully to

avoid damaging any plastics or metals. Do not use high pressure hoses or steam cleaners to clean the engine bay to avoid water entering the electronic control module or fuse boxes.

## Polishing and Waxing

Wax the vehicle regularly to protect the paintwork when off-roading or wading. Some polishing products might be designed with silicone to leave a temporary protective layer, read the manufacturers instructions to determine if wax also needs to be applied. Polishing the vehicle will remove light swirling or marking from harsh environments, but a wax or sealant should be applied to add a protective layer to the paintwork. If the vehicle is waxed and sealed, water will bead off the vehicle when driven in the rain or after short periods of wading. Apply products as instructed by the manufacturers instructions label.



*NOTE: Do not treat plastic trims and parts with the polish or wax, this might discolour and damage the parts.*

## Override Protection



**CAUTION:** Heavy off-road use only permitted with adequate fuel tank protection (override protection).

The vehicle underbody has sacrificial protective panels as standard to protect the radiator, fuel tank and then the exhaust system on the Station / Utility Wagon only. The sacrificial protective panels are designed to protect the radiator, fuel tank and exhaust system

# MAINTENANCE AND TECHNICAL INFORMATION

against damage and/or corrosion when the vehicle is exposed to salt, grit, mud and water. Consult your INEOS partner for inspection and repair as necessary, especially after sustained off-road or wading use.



*NOTE: Any underbody protection work carried out should be done by an INEOS approved workshop only. Before and after winter or sustained off-roading and wading, wash the underbody and have the protective panels inspected and replaced, if necessary.*

## Body Maintenance

After washing, inspect the body of the vehicle for any signs of damage, such as, stone chips and scratches. Touch up any minor damage with a touch in pen to help slow corrosion and contact your nearest INEOS approved partner for further advice.



*NOTE: It is recommended to check the bodywork before and after driving off-road and wading, this is particularly important if you are planning on driving the vehicle on the road straight after off-roading or wading.*

## INTERIOR CARE

### Upholstery and Carpets



**WARNING:** Solvents and fumes from cleaning products may be dangerous in confined spaces. Make sure that the vehicle is well ventilated and follow the manufacturers printed instructions when using these products.



**WARNING:** Do not use petrol, furniture creams or household polishes to clean any of the interior.



**CAUTION:** Certain types of clothing, such as denim and vegetable tanned leather, are prone to 'dye transfer'. This can cause discolouration in the leather. Make sure that the affected areas are cleaned and re-protected as soon as possible.



**CAUTION:** Be careful when cleaning the interior that any clothing worn does not damage the seating fabric or leather and does not damage or scratch any of the interior surfaces. Velcro might damage the fabric interior and any clothing with sharp edging such as zip fasteners or belt buckles may tear fabrics, scratch and mark leather or may also result in the possibility of scratching plastic interior surfaces.



**CAUTION:** Do not use water to clean the dashboard, buttons, switches, LCD screens or any other electrical components as damage to the fuses and switches could

## MAINTENANCE AND TECHNICAL INFORMATION

---

occur. It is advised to use a mildly damp cloth instead or an interior cleaning product. Follow the manufacturers instructions label very carefully when using interior cleaning products, never spray products directly onto the dashboard or buttons, but spray a soft lint free cloth instead.

Only clean the vehicle interior with a mildly damp cloth or a approved interior upholstery cleaning product and follow the manufacturers instructions label carefully.

Clean the leather upholstery with clean water and a soft cloth, use leather cleaner products for heavy soiled leather. Follow the manufacturers instructions label carefully. It is advised to regularly gently brush the leather seats with a very soft hand brush to remove any dust or dirt that is dry.



**CAUTION: Do not clean the leather with house hold polishes or cleaning products. The leather may look clean after use, but the life of the leather will be significantly reduced and may start to show signs of wear much quicker.**

Fabric upholstery and carpets can be vacuumed and brushed with a soft brush to remove any dirt, mud or dust before cleaning with an interior upholstery cleaner to remove any staining or difficult to remove markings.



**CAUTION: The aniline saddle leather is untreated and is subject to staining and discolouration as it absorbs moisture and oils and will fade and/or discolour when**

exposed to the sun. Due to the nature of the material, we are unable to include the Saddle Leather Driver's Pack within our full vehicle warranty and cannot accept responsibility for any staining, fading, discolouration or any other defects typical of this leather type caused by natural wear or otherwise. By selecting the Saddle Leather Driver's Pack you acknowledge acceptance of the above information

Steering wheel and trim features should be cleaned with a mildly damp cloth, moistened with undiluted upholstery cleaner. It is recommended to do a second wipe and clean of the steering wheel and trim features, with a clean soft cloth and luke-warm water, to remove any contaminants broken down by the upholstery cleaner. This should be followed by a wipe with a clean drying towel or soft micro fiber cloth to dry.

### Seat Belt Care



**CAUTION: The seat belt webbing should be left to dry naturally, while fully extended.**



**CAUTION: Do not clean the seat belt webbing with any household cleaning products, bleach, dye or solvents as this will cause the webbing material to weaken over time.**

Make sure to fully extend the belts to clean all the webbing, use warm water and non-detergent soap to clean. Allow the seat belt to dry naturally while fully extended.

## MAINTENANCE AND TECHNICAL INFORMATION

 **NOTE:** Do not allow the belt to retract before fully dry and do not dry with heat, allow to naturally dry.

Regularly check the seat belt webbing and restraints to make sure they are all in working order, this includes the latches and buckles.

 **NOTE:** Any seat belt worn during a serious collision must be replaced by a INEOS approved service centre.

 **WARNING:** Any seat belt, buckle or latch not working correctly should be reported to the nearest INEOS approved service centre, Do not drive with the seat of the seat belt in question occupied.

### Radio and Screens

 **WARNING:** Do not use abrasives, alcoholic solvents or chemical solvents to clean them.

Use a dry clean soft cloth to clean the radio and screens in the vehicle. Only use approved cleaning products, such as, screen cleaning sprays after carefully reading the manufacturers instructions label. Spray the cloth directly and not the screens.

 **NOTE:** It is advised to press gently when wiping buttons and screens, as too much pressure may damage or scratch them.

### HOSING THE INTERIOR

 **WARNING:** Do not try to clean the interior while the vehicle is in motion.

 **WARNING:** Remove the fire extinguisher (if applicable) from the vehicle before hosing down the interior. It is critical to do this to avoid damaging the fire extinguisher, potentially leading to a malfunction when the device is used. If the fire extinguisher is exposed to water, consult your INEOS approved partner.

 **WARNING:** Do not go wading if the drainage plugs are not installed. The vehicle may flood with water.

 **WARNING:** Do not allow children to hose down the interior of the vehicle without close supervision.

 **CAUTION:** Park the vehicle on level ground before hosing the interior. Failure to do this, may result in water not travelling to the drainage plug holes.

 **CAUTION:** Do not hose anything, other than the flooring of the vehicle.

 **CAUTION:** Do not use a high pressure cleaner to clean or hose out the interior

## MAINTENANCE AND TECHNICAL INFORMATION

---



**CAUTION:** Do not allow water to splash the sockets and connectors above the middle tunnel of the vehicle. For example, the USB connectors have a protective lid, but they are not spring loaded. They are not water tight and if not closed, water can enter the connectors and electrical components. This will result in damage to the connector and potentially leading to further malfunctions within the vehicle.



**CAUTION:** If the seats or seating mechanisms come into contact with water, then they should be dried immediately. Failure to do this can result in damage and corrosion.



**CAUTION:** Periodic application of grease to the seat mechanisms/channels may be required to prevent degradation of factory grease that may have been accidentally diluted/displaced when washing the interior of the vehicle. Please consult with your nearest INEOS approved partner.



**CAUTION:** Remove the tool kit from the interior of the vehicle before hosing down. Failure to remove the tool kit before hosing will result in damage to the tools within the kit.



**CAUTION:** Remove flooring mats (if applicable) before hosing down the floor for maximum drainage of water to the drainage plugs.



**CAUTION:** The Expanded Polypropylene foam (EPP) blocks, must be removed from the rear and front passenger foot-wells before hosing down the interior. Water can be trapped under the EPP foam blocks, if they are not removed before hosing down and drying the interior.



**CAUTION:** For the Station / Utility Wagon, remove the trim panel located just inside the rear loadspace entrance. This will give access to the rear drain plug inside the loading area (Not applicable to the Quartermaster).



**CAUTION:** Make sure the drainage plugs have been pulled out before hosing the flooring area of the vehicle for drainage.



**CAUTION:** The drainage plugs are not permanently attached or chained to the vehicle, take care to not misplace the plugs when hosing the flooring.



**CAUTION:** Do not use excess water to clean the interior, the cleaning and hosing out of the vehicle needs to be done carefully. For example, do not pour buckets of water into the interior as this can flood areas that can not be exposed to water.



**CAUTION:** Do not splash any electrical wires or connectors. If any electrical wires or connectors are



## MAINTENANCE AND TECHNICAL INFORMATION

exposed to moisture, they might corrode and break or result in a system failure.



**CAUTION:** Do not hose down or splash the air vent openings in the middle tunnel, they cannot be closed. Any water entering the air vents will result in damage to the heating, ventilation and air conditioning (HVAC) system within the vehicle.



**CAUTION:** Do not point the hose or direct the water into any gaps, openings or holes, where you cannot observe what the water might come into contact with.



**CAUTION:** Drainage openings in the interior trim are to allow water to drain, they must not be used for any other purpose.



**CAUTION:** Do not remove or tamper with the plastic trims located inside the door shuts, if the trims are removed you may risk voiding the corrosion warranty.

The floor area, such as, the foot-wells can be hosed out with a low pressure hose to remove any dirt or salts, that may have been trodden into the vehicle.

The maximum water flow rate when hosing down the vehicle interior, should be 5 l/min with a ½ inch water hose.

It is safe to hose down with a low pressure hose, the following areas:

- > Accelerator pedal rubber.
- > Brake pedal rubber.
- > Front and rear foot-wells.
- > Loadspace. (if applicable)
- > Removable foot-well trims.

This is not an exhaustive list but some examples of key areas that should not be hosed down under any circumstances due to the risk of malfunction:

- > Any electrical switches and plugs of the interior.
- > Wiring and electrical connectors (especially underneath both front seats).
- > Electrical components positioned under the rear seats.
- > Seat belt buckles, latches and tongues.
- > Airbags.
- > Gear Selector.
- > Steering Wheel.
- > Overhead Control Panel.
- > Front and rear seats.
- > Front seat rails and sliders.
- > Inner door trim.

## MAINTENANCE AND TECHNICAL INFORMATION

- > Roof lining.
- > Centre Console.
- > Handbrake.



**WARNING:** Do not remove the water splash guard around the base of the rear seats, this is designed to protect the electrical components from water and moisture damage, which can lead to malfunction. This also applies to the water splash guard in the loading area of the vehicle directly behind the rear seats. The water splash guards are installed to protect electrical components or connectors that might fail or malfunction, if they come into contact with moisture. Replace immediately if the water splash guards are damaged by consulting your nearest INEOS partner.



**WARNING:** Accessories, such as, the Loadspace Drawer must not be hosed down. Accessories are not corrosion resistant.

Only the flooring area should be hosed down, accessories should not be exposed to water or should be removed before hosing down of the interior.

### Remove Interior Mats (OPTIONAL)



**WARNING:** Remove interior mats before hosing or washing the interior foot-wells.



**WARNING:** If the interior mats are splashed or accidentally hosed down then they should be dried immediately.



**CAUTION:** The Expanded Polypropylene foam (EPP) blocks, must be removed from the rear and front passenger foot-wells before hosing down the interior. Water can be trapped under the EPP foam blocks, if they are not removed before hosing down and drying the interior.

Only hose down the interior if the mats are removable and the front and rear passenger EPP foam blocks are accessible and removable. Contact your INEOS approved partner for details. To remove the EPP foam blocks, loosen the two plastic retaining screws above the block

## MAINTENANCE AND TECHNICAL INFORMATION

in the foot-well. This allows the trim to flex, enabling removal of the EPP foam block for cleaning.

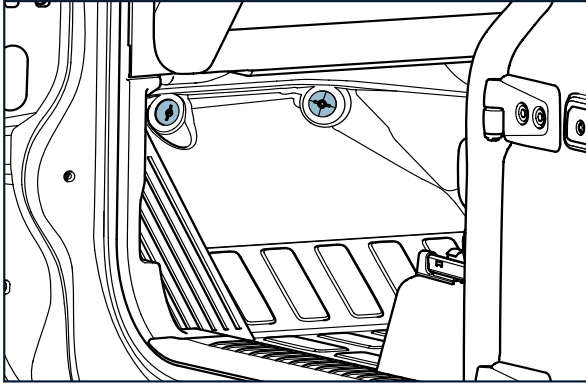

**i** *NOTE: When hosing out the flooring area of the vehicle the floor mats must be removed first. If there is non-removable mats or the floor is carpeted, then hosing down of the interior floor is not applicable.*

### Interior Drainage Plugs

**!** **WARNING:** Drainage plugs must be removed before hosing down of the interior flooring.

**!** **WARNING:** Do not leave any water in the vehicle after hosing down the interior flooring. After wipe out and drying, some water might still appear during or/and after driving, this is normal and should be dried as soon as possible.

**!** **WARNING:** Make sure the drainage plugs are re-installed correctly before driving the vehicle after hosing has been completed.

There are drainage plugs located in each of the four foot-wells in the vehicle, these plugs must be pulled out and removed and it is advised only one foot-well at a time is hosed out, this is to ensure the dirty hose water can sufficiently exit the vehicle.

**i** *NOTE: Be wary of the location in which the vehicle interior is hosed out. Dirty water exiting through the interior drain plugs is directed underneath the vehicle*

### Safe Hosing Levels

**!** **WARNING:** Only hose down the flooring area of the vehicle.

**!** **WARNING:** Hose down one foot-well at a time to allow the dirty water to drain.

**!** **WARNING:** Do not hose or splash any seating or seating mechanisms.

## MAINTENANCE AND TECHNICAL INFORMATION

 **WARNING:** Immediately dry the seats and seating mechanisms if they come into contact with any water or moisture.

 **WARNING:** Do not use anything other than a hose pipe to hose down the interior, jet washes and other powered methods of cleaning are not suitable.

 **WARNING:** Immediately dry electronics and connectors if anything is accidentally splashed and check for tell-tale warning lamps.

 **WARNING:** Always keep a firm grip of the hose pipe and never leave unattended in the vehicle at any time.

When hosing the interior of the vehicle, it is essential that only the flooring is hosed, it is recommended that any large clumps of mud or dirt should be removed before hosing and anything that might block the drainage holes should also be removed. Start by gently hosing down one foot-well at a time and allow the dirty water to drain, once the water is draining well, continue to hose the vehicle floor. Keep the hose pointing down guiding the water towards the drainage holes.

It is important to avoid water coming into contact with the seating, seating mechanisms and any electronic wiring or connectors in and around the vehicle.

 **WARNING:** There is an airbag connector located underneath both the front passenger and the front driver seat. The airbag connector should never come

into contact with water or moisture, failure to keep this connector away from water could lead to the airbag system malfunctioning or failing. The tell-tale warning lamp might illuminate, but not always, if the airbag connector has come into contact with water. If you accidentally hose, splash or expose the connector to water you should immediately contact your INEOS approved partner for further advice and information.

The vehicle battery and electrical components are stored under the rear bench seat, they are protected with a cover around the immediate safe hosing area but care should be taken. Be sure to only hose around the flooring area of the rear foot-wells to avoid any water splashing that might enter a small gap between the battery cover and the rear bench seat.

 **WARNING:** Do not hose underneath the rear bench seat, as water will drain through the access holes in the top of the battery cover, causing damage to the battery, fuses and other electronic components. If water is splashed onto the seats, dry immediately, if the water enters the battery and fuse compartments, do not attempt to touch the components and seek further advice from an INEOS approved partner.

### Hosing the Loadspace (Station / Utility Wagon)

 **WARNING:** Remove the front and rear foot-well mats (if applicable) and unplug all drainage plugs when hosing down the loadspace of the vehicle.

## MAINTENANCE AND TECHNICAL INFORMATION

 **WARNING:** Do not hose down the loadspace of the vehicle if the Carpet Flooring option is selected or there are non-removable mats in the front, middle or rear of the vehicle.

 **WARNING:** Remove all items and luggage from the vehicle loadspace and foot-wells before hosing out is started. This includes accessories and optional parts, such as, Cargo Barrier, Loadspace Divider and the Cargo Management System.

 **WARNING:** Do not stand in the loadspace of the vehicle when hosing down, as the floor can become very slippery. If this is ignored there is a high risk of injury or death.

The rear loadspace of the vehicle can be hosed out to remove any dirt or contaminants around the loadspace flooring. It is strongly recommended that the flooring is swept free of any large clumps of dirt or stones and rocks, that might block the drainage hole. When hosing the rear loadspace, it is essential that the hose is directing the water towards the drainage hole, while avoiding any splashing of water onto the back of the seats or above the flooring area of the vehicle.

 **NOTE:** The splash guard at the base of the seat back should not be removed to hose down the loadspace. Make sure the splash guard is in place to protect the seats from splashing and to make sure the water is guided away from the electrical components located underneath the rear bench seat.

 **WARNING:** The lower rear seat cushion must remain in a horizontal seating position during the hose down procedure, the backrest must be in a vertical position. This will help stop water reaching the electrical components and connectors, which are located underneath the rear bench seat.

Any excess water will be directed down the sides of the rear seats to the drainage holes within the rear foot-wells to help with drainage.

Dirty water should be guided to the drainage hole at the rear of the vehicle to help avoid puddling of water in the vehicle, this will need to be done for the interior foot-wells to remove any excess water that may have drained down the drainage channels beside the rear seats.

### Loadspace Drainage Plug (Station / Utility Wagon)

 **WARNING:** Wading or off-roading without the plugs in place could result in flooding the interior and damage to the vehicle and/or its components. This may result in a crash that may lead to injury or death.

 **WARNING:** Do not go wading in the vehicle if the drainage plug is not re-installed.

 **CAUTION:** Remove the tailgate scuff plate at the rear of the vehicle, this will give access to the drainage plug in the loadspace. If the drainage plug in the rear loadspace is not removed when hosing out the vehicle, damage can be caused.

## MAINTENANCE AND TECHNICAL INFORMATION



**CAUTION:** Re-install drainage plugs before driving the vehicle.

Remove the tailgate scuff plate before hosing down the loadspace. Remove the drainage plug which is located underneath and clear the gully of dirt. This will ensure water can flow freely down the gully and out of the drainage plug.



*NOTE: Make sure the scuff plate is re-installed correctly after re-installing the drainage plug.*

### Drying After Hosing



**WARNING:** Do not go wading or off-roading if the drainage plugs have been lost or not re-installed.



**WARNING:** Always allow the vehicle time to dry out sufficiently before driving.



**WARNING:** Do not leave the vehicle unattended when the doors and windows are open.



**WARNING:** Do not climb into the vehicle until the floor is fully dry as there is a risk of slipping and falling, which can lead to serious injury or death.

It is important to allow the vehicle to dry out completely, before driving or closing the doors and windows. Any puddling of water, should be directed to the nearest drainage hole, followed by the

wiping of any areas of the floor that is still wet, with a clean drying towel.



*NOTE: INEOS recommends that the windows and doors of the vehicle are left open to help air enter and leave the vehicle, removing any remaining moisture after manual drying is completed.*

### WHEELS AND TYRES

#### General Information



**WARNING:** Use the correct size of tyre for the vehicle, using the wrong size tyre could damage the vehicle and significantly reduce the vehicle safety.



**WARNING:** If for any reason the tyre size is changed, immediately seek advice from an INEOS approved partner. It is important to not drive the vehicle before consulting with your INEOS approved partner as the speedometer may not display the correct speed or the stability of the vehicle might be significantly different to factory fitted tyre.



**WARNING:** Do not drive the vehicle if the tyres are damaged, such as, cuts or bulges. Driving with a

## MAINTENANCE AND TECHNICAL INFORMATION

damaged tyre can result in a serious crash. If there is damage to any tyre on the vehicle, including the spare wheel, consult with your INEOS approved partner.



**WARNING:** Do not drive the vehicle, if the tyre pressure is not correct. Driving with incorrectly inflated tyres can lead to uneven wear to the tyres, significantly reducing the life of the tyre and seriously affect the handling characteristics of the vehicle.



*NOTE: Tyre pressures must be checked regularly and adjusted when necessary. It is however, recommended to check for signs of wear or damage at the same time.*

The vehicle's wheels and tires are designed for both on-road and off-road conditions, including wading. Replacements should adhere to original equipment specifications to maintain performance, handling, and suspension longevity. Non-compliant parts can significantly affect vehicle performance and handling.

### Tyre Care



**WARNING:** Do not drive the vehicle, if the tyres are showing signs of damage or wear. Consult with your INEOS approved partner immediately.



**WARNING:** Do not drive the vehicle with a low inflated or flat tyre. This can cause further damage to the vehicle, or even a crash causing injury or death.

It is important to frequently check the tyres on the vehicle, including the spare wheel. Checks should be carried out on the vehicle by the driver at least once a week if used on normal roads and before and after long journeys, or before and after every off-road use. Always check the full tyre for signs of damage.

TYRE CHECK	DESCRIPTION
Tyre pressure	Refer to the recommended tyre pressure inside the fuel flap, and ensure to check it when the tires are cold, before driving the vehicle.
Outer tyre wall	Check the outer wall for signs of damage such as cracks, bulges, cuts or lumps.
Inner tyre wall	Check the inner wall for signs of damage such as cracks, bulges, cuts or lumps.
Tyre tread	Inspect the tyre tread for foreign objects like screws, nails, stones, or glass that could potentially cause damage or puncture the tyre.

## MAINTENANCE AND TECHNICAL INFORMATION

TYRE CHECK	DESCRIPTION
Tyre tread depth	Inspect tyre tread depth to ensure it meets the minimum requirement of 1.6mm. You can use a tread depth measuring tool or check built-in wear indicators within the tyre tread pattern.
Valve caps	Ensure all valve caps are securely fitted on the tire valves. Valve caps prevent debris or dust from entering the valve, preserving its integrity and preventing air leakage.

 **WARNING:** Immediately consult with your INEOS approved partner, if any of the above is found to be wrong with any tyre on the vehicle, including the spare. Consult with your INEOS approved partner if any other damage or fault is evident.

### Station / Utility Wagon Spare Wheel and Stowage

 **WARNING:** The Station / Utility Wagon spare wheel is heavy and should only be taken off the stowage and wheel carrier with the help of another person(s).

 **WARNING:** Ensure that the damaged or punctured wheel and tyre are securely fastened with the appropriate ties or fixings during transit. Drivers may underestimate the necessary restraint to keep a load secure within the vehicle, particularly during movement. Dynamic forces exert greater pressure than static ones, requiring stronger securing measures. Store the spare wheel as low as possible in the vehicle and ensure it remains

immobile when secured. Failure to properly secure the spare wheel can lead to serious injury or death.



**CAUTION:** Do not put a punctured or damaged wheel back onto the spare wheel stowage. Any damaged or punctured wheels and tyres should be placed into the loadspace of the vehicle.

The spare wheel and tyre come standard with the vehicle and are located at the rear. Accessing the spare wheel involves removing the Spare Wheel Cover or optional Spare Wheel Lockable Storage Box (if applicable). After unlocking and removing the storage box, if present, undo the three wheel nuts securing the spare wheel. Slide off the mounting ring from the threaded studs, and remove the spare wheel. To remount it, reverse the process, ensuring the three wheel nuts are torqued to 52lb.ft (70Nm).

### Quartermaster Spare Wheel and Stowage



**WARNING:** The spare wheel is heavy and should only be taken off the stowage and wheel carrier with the help of another person(s).



## MAINTENANCE AND TECHNICAL INFORMATION

The Quartermaster spare wheel is situated on the rear left side of the Load Bay, secured by a mounting plate and central bolt. To access it, you may need to remove the optional Spare Wheel Lockable Storage Box (if present). After unlocking and removing the storage box, if necessary, remove the spare wheel from the vehicle. To reinstall it, reverse the process, ensuring the central bolt for the mounting plate is torqued to 42lb.ft (56Nm). If your vehicle has Locking Wheel Nuts, you'll also need to undo the locking nut on the spare wheel mounting plate and remove the anti-theft plate to access the central bolt. When reinstalling the spare wheel with Locking Wheel Nuts, torque the locking nut to 23lb.ft (30Nm) as per the above process.

### Changing a Road Wheel



**WARNING:** Seek assistance from an INEOS approved partner, if you are in any doubt of carrying out a wheel change procedure. Changing a wheel can be dangerous if not done correctly, risking serious damage to the vehicle and injury or death to the vehicle occupants and others around you.



**WARNING:** When changing a wheel at the roadside, always make sure the location is a safe place to carry out the procedure. The hazard warning lamps must be switched on, warning vest worn and warning triangles situated to warn other drivers of your presence.



**WARNING:** Ensure heavy luggage and passengers are out of the vehicle before raising the vehicle for a wheel change. If towing a trailer secure and disconnect it.



**WARNING:** Make sure the vehicle is on stable and level ground before lifting the vehicle, to change a wheel.



**WARNING:** Do not use the bottle jack to support the vehicle at anytime, other than to change a wheel. No persons should be under the vehicle, for any reason, when the vehicle is lifted on the bottle jack.



**WARNING:** It is recommended when jacking the vehicle up, that the other wheels are chocked to help ensure there is no unexpected vehicle movement.

To change a road wheel, follow the following procedure:

1. Before raising the vehicle off the ground, loosen each of the six wheel bolts one full rotation.
2. Raise the vehicle until the tyre of the wheel being changed is not touching the ground.
3. Remove the six wheel nuts from the wheel completely, keep one hand on the wheel when removing last wheel nut to ensure it does not fall off.
4. Remove the wheel from the vehicle carefully to prevent damage to the wheel or the vehicle.

## MAINTENANCE AND TECHNICAL INFORMATION

5. Place the wheel in a safe location away from you and the vehicle. Do not place face down as this can scratch and damage the wheel.
6. It is recommended that the immediate area of contact between the wheel and the vehicle hub is cleared of any dirt or surface corrosion.
7. Place the spare wheel onto the hub, in place of the removed wheel. Be sure to hold the wheel on with one hand to ensure it does not fall off.
8. Install the six wheel nuts back onto the threaded studs, they should be tightened enough to keep the wheel in place against the wheel hub.
9. Clear the vehicle of any obstructions, such as, tooling or the removed wheel.
10. Lower the vehicle back down slowly and safely, until the wheels are all securely on the ground and remove the bottle jack.
11. Finally, torque each of the six bolts up to 160 Nm, this must be done in the sequence shown in the image below. This ensures the wheel is securely fixed into place on the vehicle hub.

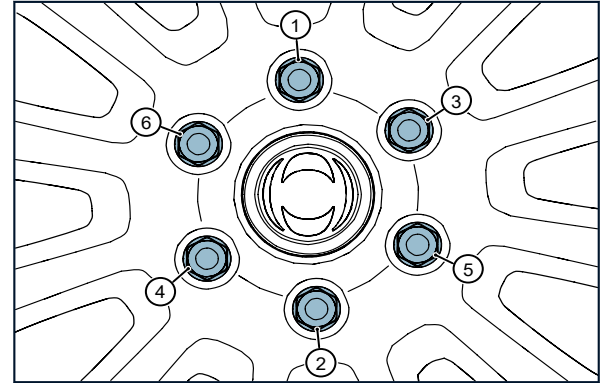

*NOTE: It is recommended that the wheel nuts are checked after a short journey to ensure they are secure.*

### Tyre - Technical Specifications

Recommended tyre brand and size:

MODEL	WHEEL DIAMETER	SERVICE TYPE	TYRE WIDTH	SIDEWALL HEIGHT	SPEED RATING	MAX LOAD
BF Goodrich All Terrain T/A KO2	17"	L T - Light truck carrying heavy load.	265	70	S	1450kg(3196 lbs)

## MAINTENANCE AND TECHNICAL INFORMATION

MODEL	WHEEL DIAMETER	SERVICE TYPE	TYRE WIDTH	SIDEWALL HEIGHT	SPEED RATING	MAX LOAD
BF Goodrich All Terrain T/A KO2	18"	L T - Light truck carrying heavy load.	255	70	S	1285kg(2832lbs)
Bridgestone Dueler AT001	17"	PSR - Passenger Tyres	265	70	S	1250kg(2756lb)
Bridgestone Dueler AT001	18"	PSR - Passenger Tyres	255	70	S	1250kg(2756lb)

There is no special recommendation for snow or off-road, as the recommended tyres are suitable for off-road and all seasons.

The recommended tyre pressures dependent on the vehicle load are as follows:

TYRE DIMENSION	FRONT, REAR, SPARE	bar	kPa	PSI	PASSENGERS AND LOAD
LT 265/70/R17 S	FRONT	2,5	250	36	Max. 3 people
	REAR	2,5	250	36	
	SPARE	3,4	340	49	
	5 people plus luggage	FRONT	3,0	300	43.5
		REAR	3,4	340	49
		SPARE	3,4	340	49
LT 255/70/R18 S	FRONT	2,5	250	36	Max. 3 people
	REAR	2,5	250	36	

## MAINTENANCE AND TECHNICAL INFORMATION

TYRE DIMENSION	FRONT, REAR, SPARE	bar	kPa	PSI	PASSENGERS AND LOAD
	SPARE	3,4	340	49	5 people plus luggage
	FRONT	3,0	300	43.5	
	REAR	3,4	340	49	
	SPARE	3,4	340	49	

### Tyre Pressure Monitoring System (TPMS)



**WARNING:** The TPMS is not a substitute for correct manual tyre maintenance, it is the driver's responsibility to maintain correct tyre pressures with a tyre pressure gauge. INEOS recommends inspection of each tyre, checking the tyre pressures, every two weeks or before and after off-road driving or wading.



**WARNING:** The tyres may overheat and potentially lead to tyre failure if substantially under-inflated. Over inflation and under-inflation also reduces fuel efficiency and tyre tread life. This can lead to tyre failure, which may then lead to loss of control, injury and even death.



**WARNING:** Always ensure tyres are correctly inflated for on-road driving. Failure to do so may result in reduced vehicle handling and performance.



*NOTE: Tyre sealants can cause damage to the tyre pressure monitoring system and should only be used in roadside emergencies.*

The TPMS is a safety feature that provides real-time individual tyre pressure and temperature readings when the wheels are in motion. It alerts the driver if any tyre pressure falls below the minimum threshold.

The TPMS system is autonomous to identify when the spare wheel is installed the system will automatically detect the new position.



*NOTE: INEOS recommends driving the vehicle for approximately 5 minutes once the spare wheel has been put in place of the wheel with a punctured tyre. Once the vehicle has been driven for 5 minutes, reset the TPMS using the infotainment screen. This is to ensure that the TPMS warning tell-tale lamp has been extinguished and the readings are true for the tyre pressures. Contact an INEOS approved partner for support if the TPMS lamp*

## MAINTENANCE AND TECHNICAL INFORMATION

*does not extinguish or there are suspected errors with the tyre pressure readings.*

The TPMS conducts an automatic self-test upon power-on. Initially, the tyre pressure warning symbol illuminates and extinguishes if no errors are detected. Persistent errors keep the symbol illuminated until resolved. Seek assistance from your INEOS approved partner for any malfunctions.

When adjusting tyre pressure, like for off-road use, reset the TPMS via the vehicle settings to establish a new pressure baseline. Before using public roads again, re-inflate tyres to proper on-road levels and reset the TPMS accordingly.

### Tyre Pressure Display

The tyre pressure display provides information for all four rotating tyres. Information displayed:

- > Tyre position.
- > Tyre pressure.
- > Tyre temperature.

### Warning Information

The following table, displays the warning information that may be visible or heard, when triggered.

FAULT	WARNING	TELL-TALE	ACOUSTIC
Tyre Pressure Leakage	Stop the vehicle, Fast leakage detected	YES	YES
Tyre Pressure Low	Tyre pressure is too low, please check	YES	YES
Tyre Pressure High	Tyre pressure is too high, please check	YES	YES
Tyre Temperature FL high (Front Left)	The temperature is too high, please check	YES	YES
System Malfunction	Contact an INEOS approved partner to check TPMS	YES	NO
Tyre Pressure Sensor Lost	Contact an INEOS approved partner to check sensor	YES	NO
Sensor Battery Low	Contact an INEOS approved partner to check sensor battery	YES	NO

# MAINTENANCE AND TECHNICAL INFORMATION

## CUSTOMER INFORMATION

### Radio Frequency Identification (RFID)

INEOS use RFID technology in the vehicle, for example, tyre pressure monitoring and radio remote controls, such as, the key fob to unlock and lock the vehicle.

INEOS vehicles with RFID do not use or record personal information with any other INEOS system containing personal information.

### Radio Conformity

#### Australia:



#### Morocco:



#### South Africa:

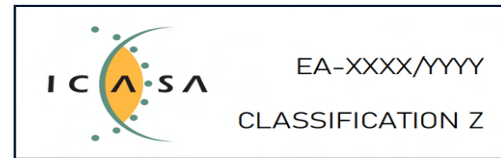
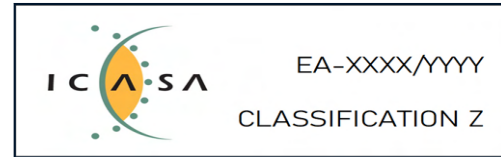

## MAINTENANCE AND TECHNICAL INFORMATION

### Qatar:

	ictQATAR Type Approval reg. No.: CRA/SM/2022/S-0011504	
	Importer No: xxxxxxx	

	ictQATAR Type Approval reg. No.: CRA/SM/2022/S-0011505	
	Importer No: xxxxxxx	

### United Arab Emirates:

<b>TDR</b> A	
ERXXXXXXXX/Y - 4579.50 UNITED ARAB EMIRATES	

<b>TDR</b> A	
ERXXXXXXXX/Y - 4721.50 UNITED ARAB EMIRATES	

<b>TDR</b> A	
ERXXXXXXXX/Y - 4734.50 UNITED ARAB EMIRATES	

### Registered Trademarks

#### Apple Inc.

Apple CarPlay™ is a trademark of Apple Inc .

App Store® is a registered trademark of Apple Inc .

iPhone® , iPod® and Siri® are registered trademarks of Apple Inc .

#### Bluetooth SIG, Inc .

Bluetooth® is a registered trademark of Bluetooth SIG, Inc .

#### Google Inc .

Android™ and Google Play™ Store are trademarks of Google Inc .

#### Verband der Automobilindustrie e.V.

AdBlue® is a registered trademark of the VDA .

#### © Unilever .

Vaseline® is a registered trademark of © Unilever .

## WARRANTY INFORMATION

---

CUSTOMER STATEMENTS .....	233
INTRODUCTION .....	233
WARRANTY COVERAGE PERIODS .....	233
THINGS YOU SHOULD KNOW ABOUT INEOS WARRANTY .....	235
GENERAL WARRANTY CONDITIONS .....	239
GENERAL MAINTENANCE .....	239
EXTREME USE SERVICING SUGGESTION .....	239



# WARRANTY INFORMATION

---

## CUSTOMER STATEMENTS

Our goods and services come with guarantees that cannot be excluded under the Australian Consumer Law. For major failures with the service, you are entitled:

- > to cancel your service contract with us; and
- > to a refund for the unused portion, or to compensation for its reduced value.

You are also entitled to choose a refund or replacement for major failures with goods. If a failure with the goods or a service does not amount to a major failure, you are entitled to have the failure rectified in a reasonable time. If this is not done, you are entitled to a refund for the goods and to cancel the contract for the service and obtain a refund of any unused portion. You are also entitled to be compensated for any other reasonably foreseeable loss or damage from a failure in the goods or service.

### Markets excluding Australia:

The warranties contained herein are in addition to and do not detract from any rights you may have under your local consumer legislation.

## INTRODUCTION

INEOS Automotive Limited ("INEOS") issues a warranty for each new INEOS vehicle sold, registered and operated where authorised INEOS dealers or agents are located by a customer. Within the period of time and mileage specified in the table below, an INEOS Automotive

Approved Workshop will repair (or, at INEOS' option) replace free of charge those parts or components which are covered by the section's description and which prove defective in materials or workmanship. Parts which are excluded from warranty are listed under "what is not covered". The method of repairing or replacing is to be determined by the INEOS Automotive Approved Workshop.

All warranties provided by INEOS are subject to the terms and conditions and exclusions, referred to below.

## WARRANTY COVERAGE PERIODS

The warranties in this document include the following:

### New Vehicle Warranty

The INEOS New Vehicle Warranty, as defined in the 'Warranty Coverage Period Table', covers all parts and components of each new INEOS vehicle supplied by INEOS, which prove defective in materials or workmanship.

### Paint Warranty

The Paint Warranty, as defined in the 'Warranty Coverage Period Table', covers painted body parts (excluding the underbody) which suffer from paint defects as a result of defective materials or workmanship.

### Anti Perforation Warranty

The Anti Perforation Warranty covers body sheet metal panels and chassis frame which suffer from inside-to-outside perforation from

## WARRANTY INFORMATION

corrosion, as a result of defective materials or workmanship. The period for the Anti Perforation Warranty is 12 years from warranty start date.

This warranty requires that the vehicle is inspected, and repaired, if necessary, by an authorised INEOS Automotive Approved Workshop. Inspection and repair is required annually after the warranty start date.

### Genuine Parts and Accessories Warranty

INEOS Automotive Limited issues a warranty, as defined in the 'Warranty Coverage Period Table', for all INEOS genuine parts and

accessories supplied for installation on an INEOS vehicle to be free from defects in materials or manufacturers workmanship.

### Warranty Coverage Period Table

The following warranty periods apply from the date of first retail registration:

REGION	MECHANICAL	PAINTWORK	ANTI-PERFORATION	PARTS	ACCESSORIES	EMISSION
UK and Europe	5 Years unlimited mileage	3 Years unlimited mileage	12 Years	2 Years unlimited mileage	3 Years unlimited mileage	5 Years 100,000 miles (160,000 km)
Australia and New Zealand	5 Years unlimited mileage	5 Years unlimited mileage	12 Years	2 Years unlimited mileage	5 Years unlimited mileage	5 Years 100,000 miles (160,000)
Africa	5 Years 60,000 miles (100,000 km)	3 Years 60,000 miles (100,000 km)	12 Years	2 Years unlimited mileage	3 Years unlimited mileage	5 Years 100,000 miles (160,000 km)
Middle East and Asia	5 Years unlimited mileage	3 Years unlimited mileage	12 Years	2 Years unlimited mileage	3 Years unlimited mileage	5 Years 100,000 miles (160,000 km)

All warranties terminate at the end of the periods set out above.

### Emission Component Warranty

The Emission Component Warranty as defined in the 'Warranty Coverage Period Table', warrants parts installed on your INEOS

## WARRANTY INFORMATION

---

vehicle which have the sole or primary purpose of reducing your vehicles emissions to be free from defects in materials or manufacturers workmanship.

### THINGS YOU SHOULD KNOW ABOUT INEOS WARRANTY

#### Tyres

Tyres, even when originally installed on new INEOS vehicles, are warranted by the tyre manufacturer. An INEOS Automotive Limited Approved Workshop, will assist you in making a warranty claim for tyres, if necessary. INEOS is not liable for repair or replacement of the tyres or any costs relating to such repair or replacement.

#### Pre-Delivery Inspection

To make sure you will be completely satisfied with your new Grenadier from the very start, it has been inspected and prepared before delivery, according to INEOS's New Vehicle Pre-Delivery Inspection Procedure.

#### Periodic Maintenance Service

Your vehicle must be serviced in accordance with INEOS' periodic servicing schedule, be performed in accordance with INEOS recommended requirements, and carried out by your INEOS Automotive Approved Workshop.

This is to ensure good engine and emission control system performance and good mechanical condition of your new vehicle. Scan the QR code inside the 'Service and Maintenance' section, for your vehicle's servicing requirements.

Failure to adhere to this may result in your warranty claim being rejected and INEOS may ask to see evidence the vehicle has been properly serviced.

If you elect to maintain your vehicle yourself or use a non-INEOS approved workshop to perform any scheduled maintenance or repair activities, INEOS recommends you keep accurate records relating to the products, parts, fluids used, odometer reading and date of maintenance to support any future claims under the provision of the INEOS New Vehicle Warranty. We also recommend all maintenance and repairs are only performed by suitably qualified persons as errors in maintenance may lead to damage to, or operational issues with, your vehicle.

Servicing need is based on a time or mileage/Km based schedule. You should arrange an appointment with your INEOS Automotive Approved Workshop when your vehicle reaches either the appropriate mileage or time interval. For example, for a 12,000 mile (20,000 km) / 12-month maintenance schedule, the service will be due when you've driven 12,000 miles (20,000 Km) or the vehicle has been registered for one year, whichever occurs first. Vehicles should be serviced within 1,000 miles (1,600 Km) or one month of the due time or distance.

#### Genuine INEOS Parts and Accessories

Genuine INEOS parts and accessories are approved by INEOS for use on INEOS vehicles. Only genuine INEOS parts and accessories are covered by INEOS's Genuine Parts and Accessories Warranty.

Damage caused to your vehicle as a result of fitting Non-genuine Parts and Accessories is not covered by this warranty.

# WARRANTY INFORMATION

---

## Warranty Service in Other Countries

INEOS Warranties are valid in regions in which the vehicle is originally sold. However, if a warranty repair is required in another region, you can contact your local INEOS workshop who will be happy to repair your vehicle under the terms of your warranty.

For Warranty Coverage see the 'Warranty Coverage Period Table' above.

## Design or Specification Change

INEOS has the right at any time, to make changes to the design or specifications of any INEOS vehicle, without notice and without obligation to update or make changes on vehicles that sold before the update or change was implemented.

## What Is Not Covered

1. Tyres
2. Any non-genuine parts, accessories or other equipment which is not approved by INEOS for use on the vehicle.
3. Any consumables, parts and/or labour cost incurred as a result of, or in connection with, required or recommended maintenance service such as, but not restricted to, adjustments (including, but not limited to, wheel balancing and alignment, engine tune-up, headlight aiming), light bulbs, exhaust system and particulate filters (unless proven to be materially defective), spark plugs, drive belts, brake discs, brake pads, other filters, upholstery and trim, (unless

materially defective) wiper blades, fluids or lubricants, (unless replaced as part of a warranty repair)

## WARRANTY INFORMATION

4. Damage, failures or corrosion resulting from:
  - > Misuse, accident, theft, arson or intentional damage.
  - > Industrial fall-out, acid or alkali contamination, stone chipping, chemical fall-out, tree sap, bird droppings, salt, hail, windstorm, lightning or other environmental conditions.
  - > Failure to follow the relevant guidelines given in the Owner's Manual and under the caption \*what you must do\* in this section.
  - > Use which is not in accordance with (or failure to follow the relevant guidelines given in) this Owner's Manual
  - > Continuing to use the vehicle if a fault has become apparent.
  - > Failure or unreasonable delay in having the vehicle repaired at the earliest opportunity after a defect has become apparent.
  - > Failure to follow proper maintenance services as defined by INEOS.
  - > Modification or alteration of the vehicle or any parts fitted to it or improper repair.
  - > Repairs not performed by an authorised INEOS Automotive Approved Workshop.
  - > Use of non-genuine parts, accessories or other equipment which is not approved by INEOS for use on the vehicle; or
  - > Use of improper or contaminated fuel, fluids, or lubricants.
5. Normal deterioration of trim, paint, or other cosmetic items (normal wear and tear).
6. Any vehicle on which the odometer has been altered or replaced so that the reading does not correspond with the actual mileage of the vehicle or on which the Vehicle Identification Number and/or Engine Number have been altered or removed.
7. Incidental or consequential damages such as loss of use of the vehicle, inconvenience, or commercial loss.
8. Any vehicle that has previously been involved in an incident that in INEOS' sole discretion rendered the vehicle as a total loss or which an insurer has previously decided was a total loss, because it was lost, stolen, destroyed or damaged beyond economic repair (whether or not this was your fault or the fault of the registered owner at the time of the incident).
9. Damage or other wear arising from racing, track days, off-road trials, other competition, or events.
10. Investigative/diagnostic work in connection with a fault which is not covered by this warranty.
11. Paintwork, bumpers, grilles and other bodywork (except where this is covered under the Paint Warranty).

## WARRANTY INFORMATION

---

12. Paintwork which is covered by any stickers or vinyl wraps.
13. Stripping or dismantling of the vehicle except as part of a valid warranty claim.
14. Labour time associated with the removal of any aftermarket accessories fitted to the vehicle in cases where access is restricted by the accessory and removal is required to replace a defective component in completing a warranty repair.

### What We Will Do

All warrantable defects will be repaired by an INEOS Automotive Approved Workshop, at no charge to the customer for labour or parts within the limitations, set out in this Owner's Manual.

### What You Must Do

1. Properly use, maintain and care for your vehicle, as outlined in this Manual.
2. Take the vehicle to an official INEOS Automotive approved workshop place of business during regular business hours, at your expense, in order to obtain warranty service.
3. Check for trim, paint, or other cosmetic defects at the time the new vehicle is delivered and report any issues to the INEOS dealer or agent who delivered your vehicle.

4. Retain:
  - > All maintenance service records.
  - > All documents and invoices relating to parts or accessory installations.
5. As for the Paint Warranty and the Anti Perforation Warranty, you must:
  - > Carefully read vehicle care and maintenance instructions given in the Owner's Manual.
  - > Arrange for an INEOS Automotive Approved Workshop to carry out the annual paint inspection and documented on the Maintenance Record.
  - > Wash the vehicle regularly.
  - > Remove salt, sand, ice melting agents, road and oil tar, tree sap, bird droppings and other potentially harmful materials immediately when they are found on the vehicle.
  - > Promptly repair any damage to the surface finish of the vehicle at your own expense.
6. Maintain the vehicle in accordance with the "General Maintenance" section below.
7. You must not make a false, dishonest, or misleading claim. This warranty will be invalidated if we believe you have made such a claim.

# WARRANTY INFORMATION

---

## GENERAL WARRANTY CONDITIONS

The following general conditions apply to this warranty:

1. This warranty does not affect your right to make a claim under any other warranty or insurance applicable to the vehicle but INEOS may reduce the amount of any claim made under this warranty by the amount recovered under any such alternative warranty or insurance.
2. You may not cancel this warranty and no refund will be made in the event that this warranty is invalidated or transferred.
3. If you sell the vehicle privately, this warranty will transfer to the new owner. The new owner should:
  - > Contact INEOS to ensure that ownership records are updated; and
  - > Check that the requirements of this warranty have been met.
4. Some or all of the benefits of this warranty may not be available to the new owner if:
  - > the vehicle has not been maintained in accordance with the requirements of this warranty document, or
  - > the vehicle has not been used in accordance with the conditions of this warranty.
5. From time to time it may be necessary to change the terms of this warranty to reflect changes in the law. We may make

such changes by giving you no less than 1 month's notice (either directly or via our partners or our website).

6. This warranty (and any related issues) is governed by English Law and subject to the jurisdiction of the English Courts.

## GENERAL MAINTENANCE

During regular operation of the vehicle, it's important to perform general maintenance as outlined in this section. If you notice any unusual sounds, vibrations, or odours, investigate the cause or have your INEOS Automotive Approved Workshop inspect it promptly. Additionally, inform your INEOS Automotive Approved Workshop if you believe repairs are needed.

When performing any checks or maintenance work closely observe the precautions outlined in this manual.

## EXTREME USE SERVICING SUGGESTION

We've engineered the Grenadier to tackle the toughest conditions and terrains day in and day out. However, even the most rugged vehicles may require extra care when subjected to persistent extreme use. If your Grenadier falls into this category, we recommend servicing it every six months. This ensures that your Grenadier maintains the performance levels you rely on.















































# INDEX

---

## 4

400w Power Inverter & Power Sockets ..... 201

## A

About This Manual ..... 15  
Access Ladder (OPTIONAL) ..... 86  
ADAS Settings and Tell-Tale Lamps ..... 123  
AdBlue (Diesel Engine Only) ..... 89  
AdBlue Filler Location ..... 91  
AdBlue Levels and Warnings ..... 90  
AdBlue Tank Capacity ..... 195  
Advanced Driver Assistance Systems (ADAS) ..... 122  
AEB and FCW - Activation and Deactivation ..... 127  
Air Conditioning Button ..... 172  
Air Flow Zones ..... 172  
Airbag - Side Airbag (Thorax Airbag) ..... 44  
Airbag Deployment ..... 42  
Airbag Malfunction ..... 44  
Airbags ..... 41  
Airbags - Driver and Front Passenger ..... 43  
Airbags - Inflatable Curtain (IC) ..... 44  
Alcohol Interlock (AI) ..... 54  
Ambient Lamps ..... 63  
Anti-lock Brake System (ABS) ..... 103  
Audio ..... 158

Audio Options Menu ..... 159  
Audio Output Specification ..... 168  
Automatic Emergency Braking (AEB) ..... 125  
Automatic Transmission ..... 74  
Auxiliary Battery (OPTIONAL) ..... 198  
Auxiliary Charge Points (OPTIONAL) ..... 169  
Auxiliary Switch Panel and Electrical Preparation ..... 202

## B

Backrest Angle Adjustment ..... 32  
Battery ..... 196  
Battery Disposal ..... 198  
Battery Information ..... 197  
Battery Level Protection ..... 197  
Bluetooth Audio ..... 163  
Bluetooth Options ..... 163  
Body Maintenance ..... 213  
Bonnet Release ..... 186  
Bottle Jack ..... 113  
Brake Fluid ..... 192  
Brake Pad Wear Indication ..... 193

## C

Call Active ..... 155  
Capacities and Technical Information ..... 175

# INDEX

---

Car Wash Function .....	76	Customer Information .....	230
Central Control Interface (CCI) .....	139	<i>D</i>	
Centre Console Controls .....	21	Dangerous Substances .....	184
Centre Differential Lock .....	82	Data Recording .....	18
Changing a Road Wheel .....	226	Daytime Running Lamps .....	66
Changing the Battery .....	197	Dial a Call .....	154
Checks Before Driving .....	20	Diesel Particulate Filter (DPF) .....	91
Child Door Locks .....	53	Differential Lock Front and Rear .....	84
Child Restraint System Detailed Information .....	48	Differentials .....	81
Child Restraint System Seating .....	47	Dimensions .....	181
Child Safety .....	46	Downhill Assist .....	103
Child Seat and Front Passenger Airbag .....	49	Downhill Assist Activation .....	103
Child Seat Belt .....	48	Downhill Assist Adjusting the Speed .....	104
Child Seat with Seat Belt Installation .....	52	Downhill Assist Deactivation .....	104
Cleaning the Radio and Screens .....	215	Driver Drowsiness Detection - Activation .....	127
Component Location .....	15	Driver Drowsiness Detection - Deactivation .....	128
Connecting Android Auto .....	158	Driver Drowsiness Detection - Error .....	128
Connecting Apple CarPlay .....	157	Driver Drowsiness Detection(DDD) .....	127
Connecting Phone .....	151	Driving Safety .....	18
Connecting Phone Device .....	156	Driving with a Roof Load .....	87
Cruise Control .....	98	Drying After Hosing .....	222
Cruise Control Activation .....	99	<i>E</i>	
Cruise Control Deactivation .....	100	Eco Start / Stop ESS .....	57
Cruise Control Resuming Set Speed .....	99		
Cruise Control Speed Adjustment .....	99		

# INDEX

---

Eco Start / Stop Operation .....	58
Electrical Systems .....	196
Electronic Stability Control (ESC) .....	102
Emergency Stop Signal (ESS) .....	100
Emission Control .....	185
Engine Coolant .....	190
Engine Oil .....	186
Engine Oil Refill .....	190
Engine Oil Viscosity Grades .....	190
Engine Oils and Disposal Warnings .....	184
Engine Running-in .....	56
Environment Protection .....	184
ESC OFF Mode .....	102
Exterior Care .....	209
Exterior Mirrors .....	59
Exterior Utility Belt (OPTIONAL) .....	85
External Lamps .....	64
Extreme Use Warranty .....	239

## F

Fan Speed Settings .....	172
Fire Extinguisher (OPTIONAL) .....	111
First Aid Kit .....	110
First Row Reading Lamps .....	62
Folding Rear Seat .....	35

Follow Path .....	148
Forward Autonomous Collision Mitigation (FCW/AEB) .....	126
Forward Collision Warning (FCW) .....	125
Front (OPTIONAL) and Rear (ACCESSORY) Winch	117
Front Camera .....	124
Front Data-In USB Ports .....	168
Front Towing Eyes .....	116
Fuel .....	194
Fuel Economy .....	195
Fuel Level and Remaining Range Warnings .....	89
Fuel Safety .....	195
Fuel System .....	182
Fuel Tank Capacity .....	195
Fuse and Fuse Box .....	209

## G

Gear Selection .....	76
Gear Selector Positions .....	75
Gear Shift Indicator .....	78
General Warranty Conditions .....	239
Glass and Mirror Care .....	211

## H

Handbrake .....	74
-----------------	----

# INDEX

---

Hazard Warning Lamps .....	68	Infotainment General Settings .....	164
Head Restraint Adjustment .....	33	Infotainment Header .....	144
Head Restraints .....	32	Infotainment Home .....	144
Headlamp Care .....	212	Infotainment Home Audio .....	146
Headlamp Range Adjustment .....	69	Infotainment Home Favourites .....	147
Heated Front Seat .....	172	Infotainment Keyboard .....	144
High Beam .....	66	Infotainment Keypad .....	153
High Load Auxiliary Switch Panel and Electrical Preparation (OPTIONAL) .....	203	Infotainment Navigation Bar .....	143
Highlight Cursor .....	142	Infotainment Options Menu .....	142
Horn .....	24	Infotainment Pathfinder File Transfer Menu .....	168
Hosing The Interior .....	218	Infotainment Search .....	153
Hosing the Loadspace .....	221	Infotainment Settings Menu .....	163
/		Infotainment Sub Menu .....	151
Ignition Position .....	57	Infotainment Vehicle Functions Settings .....	165
Incoming Call .....	154	Intelligent Speed Assist - Overspeed Warning .....	133
Indicators .....	67	Intelligent Speed Assist - Speed Change Notification .....	134
Infotainment Acoustic Settings .....	166	Intelligent Speed Assist - Update Maps .....	136
Infotainment Call Bar .....	155	Intelligent Speed Assist (ISA) .....	132
Infotainment Communication Settings .....	166	Intelligent Speed Assist Activation .....	133
Infotainment DAB .....	161	Intelligent Speed Assist Deactivation .....	134
Infotainment Device Menu .....	155	Intelligent Speed Assist Error .....	135
Infotainment Display Settings .....	164	Intelligent Speed Assist Limited .....	133
Infotainment FM/AM .....	160	Interior & Loadbay Utility Rails (OPTIONAL) .....	85
		Interior Care .....	213

# INDEX

---

Interior Drainage Plugs .....	219
Interior Lamps .....	62
Interior Mats .....	219
Interior Mirror .....	60
ISOFIX (Lower Universal Anchorage System) / i-Size - Rear Seat .....	50
ISOFIX and I-Size Anchors .....	49

## *J*

Jacking Up the Vehicle .....	115
Jump Start Procedure .....	119
Jump Starting .....	119

## *K*

Key and Immobiliser .....	28
Key Fob Battery Replacement .....	28

## *L*

Lane Departure Warning (LDW) .....	129
Lane Departure Warning Activation .....	130
Lane Departure Warning Deactivation .....	131
Lane Departure Warning Error .....	131
LED Auxiliary High Beam Lights .....	68
Loadspace Drainage Plug .....	222
Loadspace Lamps .....	63

Lockable Front and Rear Differentials (OPTIONAL) .....	82
Low Beam .....	65
Lower Universal Anchorage System .....	49

## *M*

Manual Mode and Shifting .....	77
Mass and Load .....	177
Media and Infotainment .....	138

## *N*

NATO Outlet .....	203
-------------------	-----

## *O*

Occupant Restraint System .....	36
Off-Road Driving .....	94
Off-Road Electrical .....	150
Off-road Mode .....	95
Off-Road Pathfinder Navigation Mode .....	148
Off-Road Statistics .....	149
Off-Road Temperature .....	147
Off-Roading Attitude .....	147
Opening Fuel Cap .....	89
Opening Fuel Flap .....	89
Overhead Control Panel .....	23
Owner Maintenance Checks .....	185



# INDEX

---

## P

Paint Work Care .....	212
Park Distance Control .....	105
Parking Aid Systems .....	105
Parking Distance Control Malfunction .....	107
Parking Sensor Activation .....	106
Parking Sensor Deactivation .....	106
Parking Sensor Operation .....	107
Particulate Filters .....	91
Parts and Lubricants .....	182
Passenger Airbag Deactivation .....	44
Permanent 4x4 .....	81
Phone .....	150
Polishing and Waxing .....	212
Premium Sound System (OPTIONAL) .....	204
Pre-tensioner and Load Limiting .....	38
Puddle Lamps (OPTIONAL) .....	63

## Q

QR Code .....	181
Quartermaster Loadbay Lamp (OPTIONAL) .....	70
Quartermaster Tailgate Capacity .....	181

## R

Radio Conformity .....	231
------------------------	-----

Radio Frequency Identification (RFID) .....	230
Raised Air Intake (OPTIONAL) .....	97
Raised Air Intake Cyclone Pre-Cleaner (ACCESSORY) .....	97
Rear Fog Lamps .....	67
Rear Window Wiper (If Applicable) .....	72
Rear-View Camera (OPTIONAL) .....	108
Rear-View Camera Activation .....	108
Rear-View Camera Deactivation .....	109
Recirculation Button .....	172
Record Path .....	148
Recovery .....	115
Registered Trademarks .....	231
Restraint System .....	182
Reverse Lamps .....	68
Road Wheel Care .....	212
Roadbook .....	149
Roadside Emergencies .....	109
Rolling or pushing the Vehicle .....	76
Roof Loading .....	86

## S

Safari Windows (OPTIONAL) .....	61
Safe Hosing Levels .....	220
Seat Adjustment .....	30

# INDEX

---

Seat Belt care .....	215
Seat Belt Fastening .....	39
Seat Belt Reminder .....	40
Seat Belt Unfastening .....	40
Seat Belts .....	38
Seating .....	30
Seating Driving Position .....	30
Service and Maintenance .....	181
Service History .....	181
Servicing and Maintenance Safety Precautions ...	183
SOS Emergency Call (eCall) .....	109
Spare Wheel and Stowage (Quartermaster) .....	225
Spare Wheel and Stowage (Station / Utility Wagon) ....	224
Starting and Stopping the Engine .....	56
Starting the Engine .....	57
Steering Wheel Adjustment .....	25
Steering Wheel Controls .....	24, 140
Switching Off the Engine .....	57
 <i>T</i>	
Tell-tale Cluster .....	27
Temperature Auto Settings .....	172
Tether Anchor Points .....	51
Tool Kit .....	111

Toot .....	24
Towing a Trailer .....	120
Towing Capacity .....	120
Towing On All Four Wheels .....	117
Trailer Stability Assist .....	120
Transfer Case Selector Positions .....	80
Transporting the Vehicle .....	117
Tuner .....	159
Two-Speed Transfer Case .....	78
Tyre - Technical Specifications .....	228
Tyre Care .....	224
Tyre Pressure Display .....	229
Tyre Pressure Monitoring System .....	229
Tyre Pressure Warning Information .....	230

## *U*

Under Bonnet Cleaning .....	212
Underride Protection .....	213
Uphill Assist .....	104
Upholstery and Carpet Care .....	214
USB Audio Connection .....	161
USB Connectivity .....	168
USB Options .....	162

## *V*

# INDEX

---

Vehicle Loading .....	84
Vent Adjustment .....	173
VIN Vehicle Identification and Engine Number .....	17
Volume and Mute .....	140
Volumes and Loadspace .....	178

## W

Wading Mode .....	96
Warning Triangle .....	111
Warning Vest .....	111
Warranty .....	233
Warranty Coverage Periods .....	233
Warranty General Maintenance .....	239
Washer Fluid Level .....	186
Washing the Vehicle .....	210
Water Separator .....	191
Wheels and Tyres .....	222, 223
Window Demist Front .....	173
Window Demist Rear .....	173
Windows .....	59
Windows and Mirrors .....	58
Windscreen Washers .....	73
Windscreen Wiper .....	71
Wiper Blade Replacement .....	193



**Version: 02.00 - en-GB**





